



Designation: **C1298 – 95 (Reapproved 2013) C1298 – 21**

## Standard Guide for Design and Construction of Brick Liners for Industrial Chimneys<sup>1</sup>

This standard is issued under the fixed designation C1298; the number immediately following the designation indicates the year of original adoption or, in the case of revision, the year of last revision. A number in parentheses indicates the year of last reapproval. A superscript epsilon ( $\epsilon$ ) indicates an editorial change since the last revision or reapproval.

### 1. Scope\*

1.1 This guide covers procedures for the design, construction, and serviceability of brick liners for industrial chimneys. The structural design criteria are applicable to vertical masonry cantilever structures supported only at their base, either by a foundation, a concrete pedestal, or by some means from the outer concrete shell. Excluded from direct consideration are single-wythe, sectional brick linings that are supported on a series of corbels cast in the outer chimney shell.

1.2 The values stated in inch-pound units are to be regarded as the standard. The values given in parentheses are for information only.

1.3 *This standard does not purport to address all of the safety concerns, if any, associated with its use. It is the responsibility of the user of this standard to establish appropriate safety, health, and environmental practices and determine the applicability of regulatory limitations prior to use.*

1.4 *This international standard was developed in accordance with internationally recognized principles on standardization established in the Decision on Principles for the Development of International Standards, Guides and Recommendations issued by the World Trade Organization Technical Barriers to Trade (TBT) Committee.*

### 2. Referenced Documents

#### 2.1 *ASTM Standards:*<sup>2</sup>

[C395](#) Specification for Chemical-Resistant Resin Mortars (Withdrawn 2021)<sup>3</sup>

[C466](#) Specification for Chemically Setting Silicate and Silica Chemical-Resistant Mortars (Withdrawn 2021)<sup>3</sup>

[C980](#) Specification for Industrial Chimney Lining Brick

~~[E447](#)~~[C1314](#) Test Method for Compressive Strength of Laboratory-Constructed Masonry Prisms (Withdrawn 1997)

[E111](#) Test Method for Young's Modulus, Tangent Modulus, and Chord Modulus

#### 2.2 *ACI Standard:*

[307–88](#) Practice for the Design and Construction of Cast-In-Place Reinforced Concrete Chimneys<sup>4</sup>

#### 2.3 *ASCE Standard:*

[ASCE 7-88](#) Minimum Design Loads for Buildings and Other Structures (Formerly ANSI A58.1)<sup>5</sup>

<sup>1</sup> This guide is under the jurisdiction of ASTM Committee C15 on Manufactured Masonry Units and is the direct responsibility of Subcommittee C15.05 on Masonry Assemblies.

Current edition approved June 1, 2013; June 1, 2021. Published June 2013; June 2021. Originally approved in 1995. Last previous edition approved in 2007; 2013 as C1298 – 95 (2007); (2013). DOI: 10.1520/C1298-95R13; 10.1520/C1298-21.

<sup>2</sup> For referenced ASTM standards, visit the ASTM website, [www.astm.org](http://www.astm.org), or contact ASTM Customer Service at [service@astm.org](mailto:service@astm.org). For *Annual Book of ASTM Standards* volume information, refer to the standard's Document Summary page on the ASTM website.

<sup>3</sup> The last approved version of this historical standard is referenced on [www.astm.org](http://www.astm.org).

<sup>4</sup> Available from American Concrete Institute (ACI), P.O. Box 9094, 38800 Country Club Drive, Farmington Hills, MI 48333-9094, <http://www.aci-int.org>; 48331-3439, <http://www.concrete.org>.

<sup>5</sup> Available from American Society of Civil Engineers (ASCE), 1801 Alexander Bell Dr., Reston, VA 20191, <http://www.asce.org>.

\*A Summary of Changes section appears at the end of this standard

## 2.4 Other Standard:

[1991 Uniform Building Code, International Conference of Building Code Officials, California](#)<sup>6</sup>  
[TMS 402/602 Building Code Requirements and Specifications for Masonry Structures](#)<sup>7</sup>

## 3. Terminology

### 3.1 Notations:

$a$	=	brick dimension in radial direction (in.)
$b$	=	brick dimension in tangential direction (in.)
$c$	=	brick chamfer (in.)
$C_e$	=	chimney deflection due to earthquake loads (in.)
$d$	=	outside diameter of brick liner (in.)
$D$	=	mean liner diameter at a given elevation (in.)
$E_m$	=	masonry modulus of elasticity as established by performing brick prism test or by past experience, psi
$f_b$	=	critical liner buckling stress, psi
$f_d$	=	maximum vertical compressive stress due to dead load, psi
$f_{de}$	=	maximum vertical compressive stress due to the combined effect of earthquake and dead load, psi
$f_{dw}$	=	maximum vertical compressive stress due to the combined effect of wind and dead load, psi
$f_m$	=	average ultimate masonry compressive strength established by performing brick prism test or by past experience, psi
$f_v$	=	maximum shear stress due to wind or earthquake, psi
$F.S.$	=	factor of safety
$h$	=	total liner height (ft)
$h_e$	=	height of liner above elevation being checked for buckling (ft)
$L_e$	=	liner deflection due to earthquake loads (in.)
$P$	=	constructional out-of-plumbness of liner with respect to shell (in.)
$r$	=	average mean radius of liner (ft)
$S$	=	shell deflection due to sun effect (in.)
$T$	=	liner deflection due to differential temperature effects (in.)
$t$	=	wall thickness (in.)
$v$	=	coefficient of variation in brick prism tests
$W$	=	shell deflection due to design wind loads (in.)
$\alpha$	=	coefficient of thermal expansion for brick liner (use $3.5 \times 10^{-6}$ unless otherwise established) (in./in./°F)

## 4. Significance and Use

### ASTM C1298-21

#### 4.1 History: [standards.iteh.ai/catalog/standards/sist/a6af7e72-d844-4d23-8f91-637e34979cb8/astm-c1298-21](https://standards.iteh.ai/catalog/standards/sist/a6af7e72-d844-4d23-8f91-637e34979cb8/astm-c1298-21)

4.1.1 For many years, brick liners have been used with an excellent record of performance. For the most part, however, the design and construction of brick liners has been based on past industry practice due to the lack of available information and knowledge of the physical properties of the brick and mortar, the thermal and seismic behavior of brick liners, and many related characteristics that were not properly or accurately defined.

4.1.2 The use of scrubbers, which lower gas temperatures and introduce highly corrosive condensates into the flue gas system, requires many new design considerations. The effect that scrubbers have on brick liners is an ongoing area of study, since a number of liners have experienced growth- and deflection-related problems which may be attributable, at least in part, to nonuniform temperature and moisture conditions within the liners.

4.2 *Purpose*—The recommendations contained herein represent current industry practices and serve to define the pertinent considerations that should be followed in the design and construction of brick chimney liners.

## 5. Materials

5.1 *General*—The selection of suitable liner materials, those capable of resisting the environment to which they will be exposed, should be based on an evaluation of the unique operating conditions that exist in each application. Although it is not the intent to restrict the applicability of this guide, and while other materials may be appropriate in some applications, the chemical-resistant

<sup>6</sup> Available from International Code Council (ICC), 5203 Leesburg Pike, Suite 600, Falls Church, VA 22041-3401, <http://www.intlcode.org>, 500 New Jersey Avenue, 6th Floor, Washington, DC, 20001, <http://www.iccsafe.org>.

<sup>7</sup> Available from The Masonry Society (TMS), 105 South Sunset St, Suite Q, Longmont, CO, 80501, <http://www.masonrysociety.org>.

brick and mortar standards set forth in 5.2 and 5.3 define the type of materials used in the majority of brick liners that are specified, designed, and erected today. All portions of this guide reflect test data, design requirements, and other practices as they relate to these materials. The provisions of this guide should be carefully reviewed for applicability if other materials are specified or used. Due to a greater knowledge of overall plant operation, material capabilities, and the flue gas environment, the owner's technical representative should be responsible for selecting all liner materials.

## 5.2 Brick:

5.2.1 Unless the specific application precludes their use, brick conforming to the requirements of Specification C980 should be used. Specification C980 covers solid kiln-fired brick made of clay, shale, or mixtures thereof.

5.2.2 Three types of brick are defined in Specification C980: Types I, II, and III. By definition, the brick types vary, respectively, in decreasing degrees of absorption and acid solubility. These bricks generally are resistant to all acids and alkalis (with the exception of acid fluorides and strong, hot caustics). Types I, II, and III brick safely will withstand continuous temperatures up to 750°F. Generally, the bricks will withstand short-term exposure to temperatures in excess of 750°F, but the capability of the bricks to resist higher temperatures should be studied case by case. The selection of the brick type and the potential need for testing beyond the requirements of Specification C980 should be determined on an individual project basis.

5.2.3 Specification C980 brick Types I and II generally are available from any manufacturer who makes double-sized, kiln-fired, solid brick for corrosion-resistant applications. The stringent requirements for Type III brick, however, make it more difficult and expensive to manufacture. Consequently, availability of Type III brick is limited; therefore, before specifying Type III brick, determine both the necessity of its use and its availability.

## 5.3 Mortar:

5.3.1 Unless specific application requirements dictate otherwise, mortar should conform to the requirements of one of the brick types listed herein.

5.3.1.1 *Specification C466*—These widely-used mortars exhibit excellent resistance to most acids (except hydrofluoric acid), water, solvents, and temperatures to 1200°F. These mortars are also resistant to intermittent exposure to mild alkalis, but their primary capability is resisting the strong acids commonly found in fossil-fuel flue gas environments.

5.3.1.2 *Specification C395*—Organic resin-type mortars (such as Furan mortar) have been used in brick chimney liners, mainly due to their capacity to resist a wider variety of chemicals than inorganic mortars. Generally suitable for use over a wider pH range, they resist non-oxidizing acids, alkalis, salts, water, and temperatures to 350°F.

5.3.1.3 High alumina cement (HAC) mortars, while not generally used in brick chimney linings, also are available. They are usually used in conjunction with heat-resistive aggregates and may be suitable for some chimney applications.

5.3.2 It is important to recognize that the selection of the proper mortar is essential to successful functioning of a brick liner. The various types of chemical-resistant mortars should be evaluated to determine which is the most suitable for a given application and set of operating conditions.

5.4 *Appurtenances*—Due to the availability of a wide variety of metallic materials and the great variations in the flue gas conditions to which materials are exposed, it is beyond the scope of this document to make recommendations regarding the suitability of materials for liner appurtenances such as breeching ducts, bands, lintels, buckstays, hoods, caps, and doors. The selection of these materials can be made only by evaluating the specific factors and conditions that exist on each individual project. One must evaluate the operating environment, projected maintenance requirements, and other such technical and economic evaluation factors commonly associated with the process of material selection.

5.5 *Field Testing*—If it is determined that field testing is required for a particular project, the test methods and acceptance criteria should be agreed upon mutually by the material manufacturers, the contractor, and the owner's technical representative. Certification that the materials shipped for use on the project conform to the requirements of their respective ASTM specifications should be obtained from the manufacturer.

## 6. Construction Requirements

### 6.1 Handling and Storage of Materials:

6.1.1 Brick pallets and the individual brick units should be handled as little as possible to reduce the likelihood of cracking and chipping. While it is obviously beneficial to keep the amount of chipping and cracking to a minimum, no criteria currently exist to evaluate what constitutes acceptability. Therefore, if deemed necessary, the specifier should include acceptance criteria in the project specification. Cracking is not always evident, and pallets suspected of containing cracked brick should be checked closely by removing individual samples. Badly damaged or cracked brick should not be used.

6.1.2 Mortar and brick should be kept dry and free from frost during construction. Heated storage sheds should be used when the ambient temperature during construction is below 40°F (4°C) unless otherwise recommended by the manufacturers of the brick or mortar. mortar and procedures in TMS 402/602 are followed.

### 6.2 Brick Sizing:

6.2.1 It is standard industry practice to use chamfered brick to approximate the circular liner shape. The proper chamfer-to-diameter relationship is shown in Fig. 1. In certain cases, it may be necessary to use two or more chamfers for a liner with a larger change in diameter over its height. The proper chamfer will keep mortar joint size variation to a minimum, resulting in tight, acid-resistant vertical seams.

6.2.2 Double-sized brick, typically 3¾ by 4½ by 8 in., is used in brick liner construction, although any other brick size that meets the recommendations of this guide is acceptable.

### 6.3 Brick Bonding:

6.3.1 The use of proper brick bonding techniques inhibits delamination, resulting in stronger, more crack-resistant walls. A proper brick bond will limit the propagation of cracks.

6.3.2 To minimize the effects of tolerance differences between “stretchers” (brick laid in the circumferential direction) and “headers” (brick laid in the radial direction), it is beneficial to reverse the brick bond frequently. As a minimum requirement, the brick bond for all wall thicknesses should be reversed, or staggered, after every three courses.

6.3.3 Circumferentially, brick should be staggered from course to course to prevent the stacking of vertical joints. Since brick liners are commonly tapered, occasional vertical alignment of radial joint will inevitably occur and is considered acceptable practice.

### 6.4 Mortar Usage:

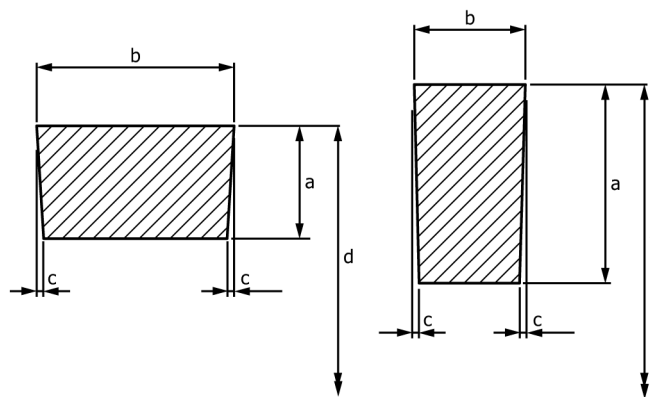

$$C = \text{chamfer (each side)} = \frac{ab}{d} \text{ (to nearest } \frac{1}{16} \text{ in.)}, \text{ in.}$$

a = brick dimension (radial direction), in.

b = brick dimension (tangential direction), in.

d = outside diameter brick liner, in.

FIG. 1 Brick Chamfers

6.4.1 Mortar should be stored and used in accordance with the manufacturer's recommendations. Mortar manufacturers generally make representatives available to assist field personnel during initial mixing and material handling operations.

6.4.2 Chemically-setting mortars typically used in brick liners are sensitive to changes in temperature and humidity, and small variations in mix proportions. The builder should monitor the mortar consistency during the course of construction. Any changes in the visual appearance of the mortar, or changes in handling, mixing, and setting characteristics immediately should be brought to the attention of the manufacturer.

6.4.3 The working time for a chemically-setting mortar is short compared to that for a Portland cement mortar. Only mortar quantities that can be used within their working time should be mixed, since retempering of these mortars is not recommended by the manufacturers.

6.4.4 All brick in the masonry chimney lining should be laid with full-bed, circumferential, and radial mortar joints. Mortar shall be applied to the brick by the use of a trowel. All mortar joints on the interior surface of the liner shall be trowel-struck.

6.5 *Rate of Construction*—A typical liner is constructed from a multiple-point suspension scaffold, which facilitates a fast rate of construction, even to the point of making it possible to build greater heights of freshly laid masonry than is warranted by the setting rate of the mortar. This is particularly true when constructing small diameter liners when the ambient temperature is low. Building at a rate faster than is warranted by the setting characteristics of the mortar can result in premature cracking and deformation of the lining. The rate of brick laying and the mortar set time should be monitored so that partially set masonry is not damaged and tolerances are maintained.

#### 6.6 *Banding:*

6.6.1 For optimum performance, the bands should be installed snugly around the liner, recognizing that some circumferential expansion will occur under thermal loading. The bands should be positioned either by the use of vertical supports or by placing the band on offset brick. The brick should then be laid directly against the pre-positioned band. Applied alone, this method of band installation should yield adequate contact between the brick and the band around the full circumference. Provided such a method and good construction practices are employed, the filling of any remaining gaps between the brick and band may not be necessary.

6.6.2 In the event that post-tensioned band connections are used, the bolts should not be tightened until the mortar has set up sufficiently that it will not deform under tightening. [ASTM C1298-21](https://standards.iteh.ai/catalog/standards/sist/a6af7e72-d844-4d23-8f91-637e34979cb8/astm-c1298-21)

<https://standards.iteh.ai/catalog/standards/sist/a6af7e72-d844-4d23-8f91-637e34979cb8/astm-c1298-21>

#### 6.7 *Tolerances:*

6.7.1 The brick liner should be constructed within the following tolerances:

6.7.1.1 *Vertical Alignment*—The center point of the liner should not vary from its vertical axis by more than 0.10 % of its height or 1 in., whichever is greater, at any point during construction. Locally, the center point of the liner should not vary by more than 1 in. in 10 ft.

6.7.1.2 *Diameter*—The measured diameter at any elevation should not vary from the theoretical diameter by more than 2 %.

6.7.1.3 *Local Deviations*—The measured radius from the center point of the liner at any elevation should not vary by more than 2 %.

6.7.1.4 *Interior Surface*—The maximum projection or offset between bricks on the interior surface of the liner should not exceed 1/8 in.

6.7.1.5 *Mortar Joints*—All joints should be laid with 1/8 in. minimum thickness. Mortar joint width depends on the actual brick dimensions, brick chamfer, brick warpage, bonding construction, and the characteristics of the mortar being used in the liner construction. Quality workmanship and industry practice should maintain mortar joint widths not greater than 1/4 in.

## 7. Design of Brick Liners

7.1 This section recommends the criteria to be used in the design of circular brick chimney liners. Included are the procedures to

be used in determining masonry strength and calculating loads and stresses in the liner. This section also provides guidelines for establishing limits on liner geometry for special design considerations through openings and for proper annular clearances.

## 7.2 *General Design Considerations:*

7.2.1 Brick liners should be designed to resist stresses resulting from the weight of the liner (including attachments), from earthquake, and from wind on projecting areas of the liner.

7.2.2 The stress should be computed and combined in accordance with the methods described herein and should not exceed the allowable stresses specified in 7.6.

7.2.3 The following limitations on liner geometry are recommended:

7.2.3.1 The minimum wall thickness should be 8 in.

7.2.3.2 The height of any segment of liner wall of a given thickness should not exceed 250 ft.

7.2.3.3 The mean liner diameter-to-wall thickness ratio ( $D/t$ ) at any elevation should not exceed 60.

7.2.3.4 The minimum thickness of the wall at the breaching opening location should be 12 in.

7.2.3.5 Wall thickness changes should be made on the exterior surface of the liner.

7.2.3.6 An opening width should not exceed one-half the internal diameter of the liner at the opening elevation. The liner taper may be governed by this requirement.

7.2.3.7 In the case of multiple openings in a given cross section, the cumulative width of the openings should not exceed one-half the inner liner circumference at that elevation.

7.2.3.8 The openings defined above should include adequate clearance for breaching stiffeners, packing seals, or other pertinent details. Internal bracing, if permitted by specification, may be utilized to reduce the size of external stiffeners.

7.3 *Determination of Masonry Strength*—Brick masonry strength ( $f_m$ ) should be determined by one of the following methods:

### 7.3.1 *Method No. 1—Standard Practice:*

7.3.1.1 Sufficient testing on materials typically used in brick liners has been performed to establish masonry strength ( $f_m$ ) safely in the instances when these materials are used. The  $f_m$  for brick that conforms to the minimum requirements of Specification C980 and mortar that conforms to the minimum requirements of Specification C466 may be taken equal to 5300 psi.

### 7.3.2 *Method No. 2—Brick Prism Tests:*

7.3.2.1 By direct testing in a laboratory environment, determine the average 28-day compressive strength of the brick masonry to be used in the design of the brick liner. Perform testing as follows:

7.3.2.2 The prisms should be built with the same materials that are to be used in the construction of the liner. That is, the materials used for testing should meet the same minimum material specification requirements as stipulated by the project specification, and also be made by the same manufacturers who produce the construction materials.

7.3.2.3 All factors and conditions, such as the quality of workmanship, mortar consistency, and joint thickness, should be the same as used in constructing the liner.

7.3.2.4 A minimum of five prisms should be constructed as shown in Fig. 2.

NOTE 1—Prism size shown was chosen as the standard prism in order to avoid height correction factors.



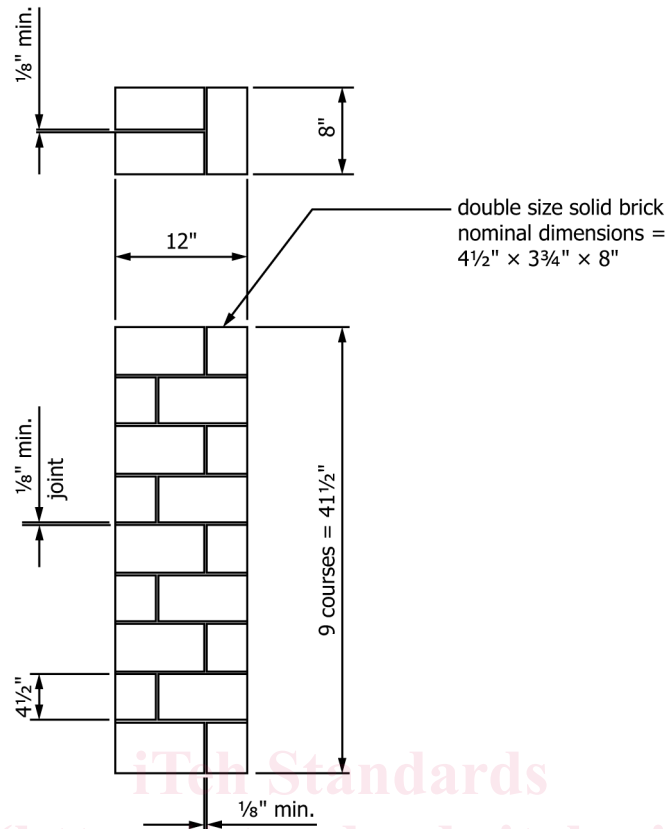

FIG. 2 Standard Prism

7.3.2.5 After construction, the prisms should be stored at or above the minimum temperature specified for mortar usage, but not less than 50°F for the duration of the curing period.

7.3.2.6 The prisms should be tested at 28 days in accordance with the relevant provisions of Test Methods [E447C1314](#).

7.3.2.7 When loading the prisms, strain measurement should also be taken and a stress-versus-strain curve plotted. The compressive modulus of elasticity ( $E_m$ ) of the masonry shall be determined in accordance with the provisions of Test Method [E111](#), using the initial tangent method and the resulting value utilized in the final design calculations for the liner.

7.3.2.8 If the coefficient of variation ( $v$ ) of the prisms tested exceeds 10 %, multiply the average compressive strength of the five prisms by the factor shown below to determine  $f_m$ .

$$1 - 1.5(0.01v - 0.10) \tag{1}$$

#### 7.4 Seismic Analysis:

##### 7.4.1 General:

7.4.1.1 Brick liners shall be designed and constructed to resist the earthquake effects determined in accordance with the requirements of this section. The project specification should state the applicable earthquake zone in accordance with the ASCE 7-88 maps for seismic zones.

7.4.1.2 The seismic analysis of brick chimney liners should be based on either the dynamic response spectrum analysis method or the equivalent static lateral force analysis method. It is expected that the dynamic response method would yield more accurate results.

7.4.1.3 Freestanding brick liners should not be used in areas near major active faults or other strong seismicity areas, specifically Zones 3 and 4 as defined by ASCE 7-88.