



Designation: F1826 – 00 (Reapproved 2021)

# Standard Specification for Live Line and Measuring Telescoping Tools<sup>1</sup>

This standard is issued under the fixed designation F1826; the number immediately following the designation indicates the year of original adoption or, in the case of revision, the year of last revision. A number in parentheses indicates the year of last reapproval. A superscript epsilon ( $\epsilon$ ) indicates an editorial change since the last revision or reapproval.

## 1. Scope

1.1 This specification covers mechanical and electrical testing and acceptance criteria for telescoping live line tools.

1.1.1 A tool designed only for use as a measuring device need not comply with mechanical strength requirements of this specification.

1.2 The use and maintenance of this equipment is beyond the scope of this specification.

1.3 This specification does not cover multiple section or extendable section clampsticks.

1.4 The values stated in SI units are to be regarded as standard. The values given in parentheses after SI units are provided for information only and are not considered standard.

1.5 The following safety hazards caveat pertains to Section 9 only. *This standard does not purport to address all of the safety concerns, if any, associated with its use. It is the responsibility of the user of this standard to establish appropriate safety, health, and environmental practices and determine the applicability of regulatory limitations prior to use.*

1.6 *This international standard was developed in accordance with internationally recognized principles on standardization established in the Decision on Principles for the Development of International Standards, Guides and Recommendations issued by the World Trade Organization Technical Barriers to Trade (TBT) Committee.*

## 2. Referenced Documents

2.1 *ASTM Standards:*<sup>2</sup>

**D149 Test Method for Dielectric Breakdown Voltage and Dielectric Strength of Solid Electrical Insulating Materials at Commercial Power Frequencies**

**F819 Terminology Relating to Electrical Protective Equipment for Workers**

<sup>1</sup> This specification is under the jurisdiction of ASTM Committee F18 on Electrical Protective Equipment for Workers and is the direct responsibility of Subcommittee F18.35 on Tools & Equipment.

Current edition approved June 1, 2021. Published June 2021. Originally approved in 1997. Last previous edition approved in 2016 as F1826-00(2016). DOI: 10.1520/F1826-00R21.

<sup>2</sup> For referenced ASTM standards, visit the ASTM website, [www.astm.org](http://www.astm.org), or contact ASTM Customer Service at [service@astm.org](mailto:service@astm.org). For *Annual Book of ASTM Standards* volume information, refer to the standard's Document Summary page on the ASTM website.

## 3. Terminology

3.1 *Definitions*— Terminology used in this specification is in accordance with Definitions F819.

3.2 *Definitions of Terms Specific to This Standard:*

3.2.1 *acceptance test, n*—one made at the option of the purchaser to verify that a product meets design criteria.

3.2.2 *design test, n*—one made on a sample treated as representative of an industrial product. These tests generally will not be repeated in quantity production.

3.2.3 *dimensional check, n*—measurements made to verify that a product complies with the dimension stated by the manufacturer.

3.2.4 *hydrophobic, adj*—lacking affinity for water.

3.2.5 *routine test, n*—a type of test made regularly on production material.

3.2.6 *telescoping live line tool, n*—an extendable multiple section FRP tool designed to carry an attachment to perform mechanical tasks.

3.2.7 *telescoping measuring tool, n*—an extendable multiple section FRP tool designed only to measure vertical heights.

3.2.8 *visual inspection, n*—a visual check made to detect manufacturing defects.

## 4. Significance and Use

4.1 This specification shall be used for design, routine, and acceptance testing of live line and measuring telescoping tools.

## 5. Ordering Information

5.1 Include the following information when ordering telescoping live line or measuring tools, or both:

5.1.1 Quantity.

5.1.2 Catalog number.

NOTE 1—Live line tools may also be designed as a measuring tool.

5.1.3 Tested to meet ASTM Specification F1826 design tests.

## 6. Workmanship, Finish, and Appearance

6.1 The external and internal surfaces shall have hydrophobic abilities.

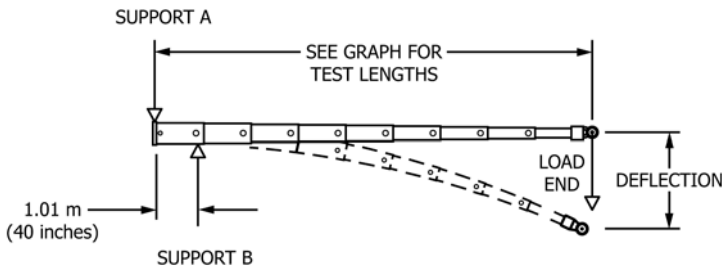
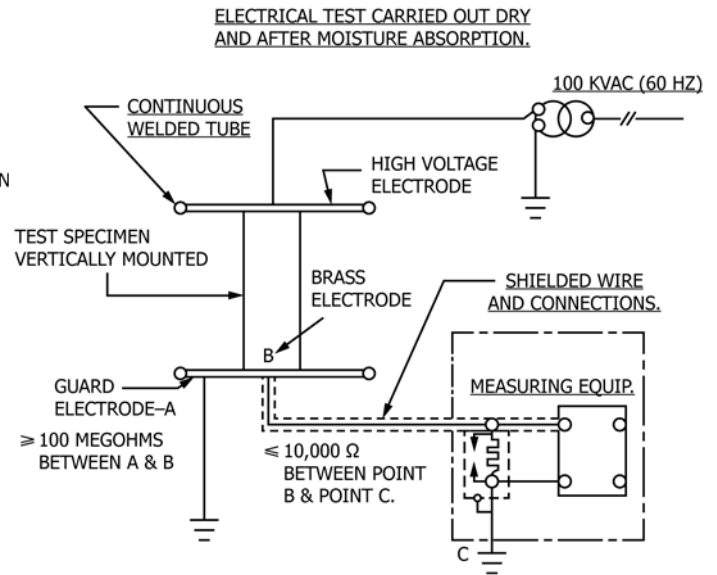

FIG. 1 Horizontal Test Set-Up



NOTE 1—For details of Fig. 4, see Figs. 5-10.  
FIG. 4 Typical AC Test Set-Up

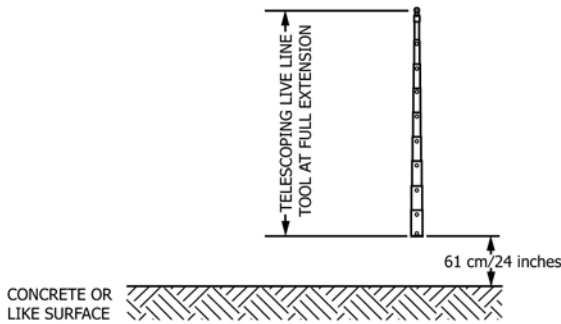

FIG. 2 Position of Stick Prior to Release for Free Fall Test

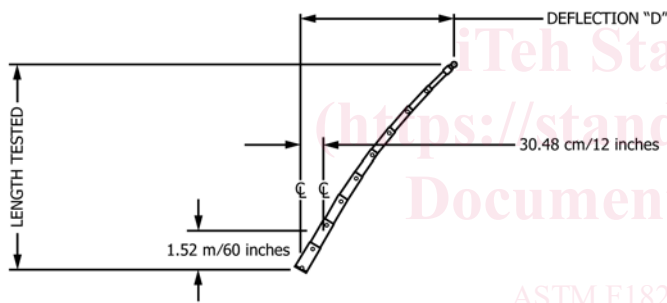

FIG. 3 Block Edge of Telescoping Stick to Obtain Correct 30.48 cm (12 in.) Centerline to Centerline Measurement

8. Tests to be Conducted

8.1 Mechanical:

Test	Type
Visual	Routine/Acceptance
Dimensional	Design/Acceptance
Horizontal Bending Deflection	Design
Free Fall Impact	Design
Tension	Design
Vertical Deflection	Design

8.2 Electrical:

Test	Type
Leakage Current	Design
Withstand	Routine/Acceptance

9. Mechanical Test Methods

9.1 Visual Inspection—In accordance with the manufactur-

6.2 The external and internal surfaces shall be free of any abrasions, scratches, blemishes and surface defects that may capture an impurity and impair the dielectric integrity of the product.

6.3 After a finish coating, such as paint, has been applied, the material shall meet all physical, electrical, and mechanical properties.

6.4 Measuring units on telescoping tools shall be readable and clearly legible on all sections designed for measuring.

7. Sampling

7.1 Design Test—Perform the test on a minimum of three samples. The design test will be used to qualify a specific item and normally will not be repeated during production.

7.2 Routine Test—Perform the test on all pieces delivered to the purchaser.

7.3 Acceptance Tests—A test made at the option of the purchaser.

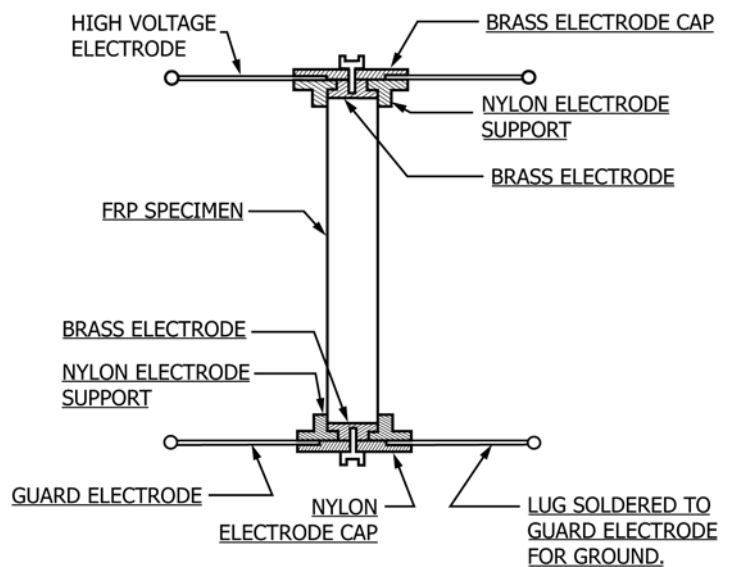
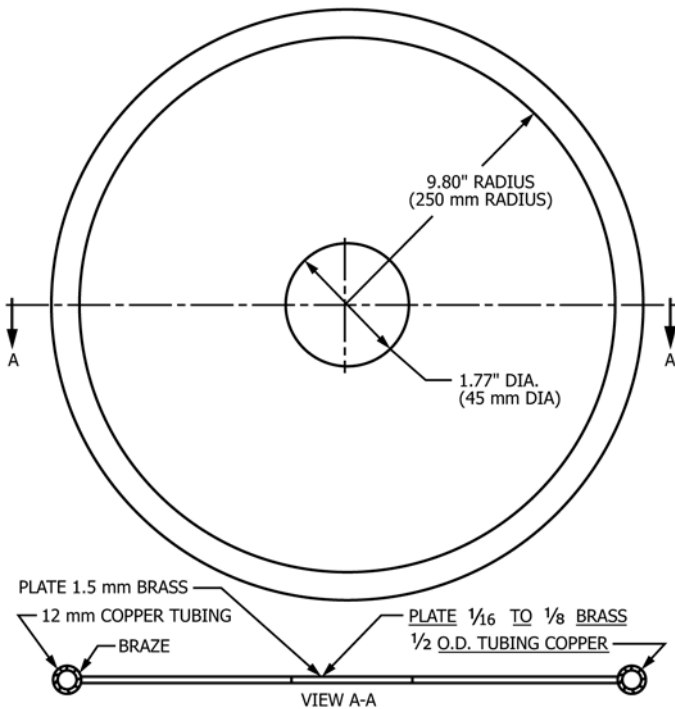
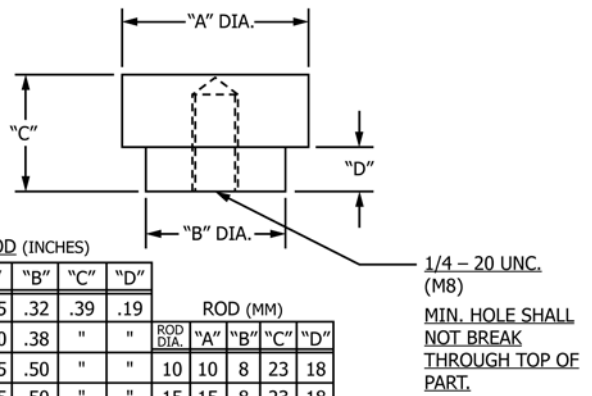

FIG. 5 Assembly Detail



**2 REQUIRED**  
**FIG. 6 Electrode Detail**



ROD (INCHES)	ROD (INCHES)				ROD (MM)				
	"A"	"B"	"C"	"D"	ROD DIA.	"A"	"B"	"C"	"D"
3/8	.385	.32	.39	.19					
1/2	.510	.38	"	"	10	10	8	23	18
5/8	.635	.50	"	"	15	15	8	23	18
3/4	.765	.50	"	"	15	15	8	23	18

TUBE (INCHES)	TUBE (INCHES)				TUBE (MM)				
	"A"	"B"	"C"	"D"	TUBE DIA.	"A"	"B"	"C"	"D"
1	1.02	.50	.39	.19	32	32	22	10	4.9
1 1/4	1.27	"	"	"	39	39	29	10	4.9
1 1/2	1.53	"	"	"	51	51	37	10	4.9
1 3/4	1.78	"	"	"	64	64	37	10	4.9
2	2.04	"	"	"	77	77	37	10	4.9
2 1/2	2.53	"	"	"					
3	3.04	"	"	"					

**2 REQ'D EACH SIZE**  
**BRASS**  
**FIG. 8 Brass Electrode Detail**

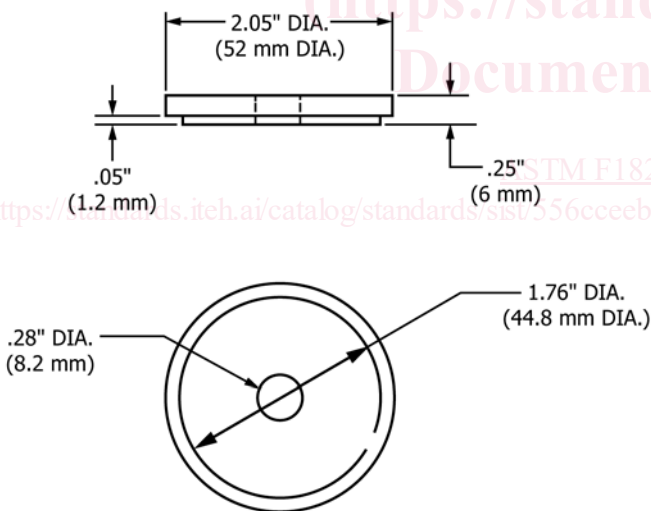

**1 REQ'D NYLON**  
**1 REQ'D BRASS**  
**FIG. 7 Electrode Cap Detail**

bonding between fibers and resin, air bubbles, foreign bodies, or particles. Check all operational components for fit and function.

9.2 *Dimensional Values*—The manufacturer, upon request by the purchaser, shall furnish product dimensional values to the customer.

9.3 *Mechanical Tests:*

9.3.1 *Horizontal Bending Deflection Tests*—When extended to the maximum length, a telescoping live line tool shall be placed horizontally in a testing device as shown in Fig. 1.

9.3.1.1 The distance between supports is 1.01 m (40 in.). Support B serves only as a fulcrum and can be a cradle to mate with the pole diameter of the location.

9.3.1.2 With telescoping live line tool fully extended and no weight added, the deflection shall not exceed the values specified in Table 1.

9.3.1.3 With telescoping live line tool fully extended, attach an external load of 2.27 kg (5 lb) to the load end. See Fig. 1. The deflection shall not exceed the values specified in Table 1.

9.3.2 *Free Fall Impact Test*—The telescoping tool shall be extended to its maximum length and shall be positioned vertically. The bottom of the tool shall be located 61 cm (24 in.) above a concrete or like surface. When released, the downward movement of the tool shall not be restricted or slowed. The tool shall not collapse or reveal significant signs of damage to the lock devices and shall display no sign of cracking of the FRP tubes. See Fig. 2.

9.3.3 *Tension Test*—When extended to the maximum length, a telescoping live line tool shall withstand a tensile load of

er's recommendation, a visual inspection shall be made to detect constructional defects, for example, evidence of faulty

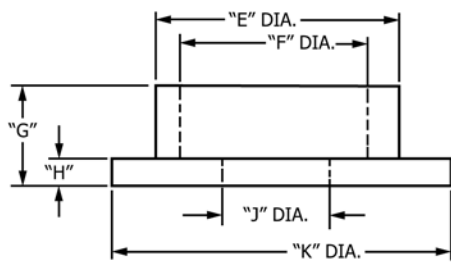

ROD (INCHES)							ROD (mm)						
DIA.	"E"	"F"	"G"	"H"	"J"	"K"	DIA.	"E"	"F"	"G"	"H"	"J"	"K"
3/8	.80	.41	.78	.20	.34	2.05	10	20	10.4	20	5	8.2	52
1/2	.90	.53	"	"	.40	"	15	25	15.04	20	5	8.2	52
5/8	1.10	.66	"	"	.52	"							
3/4	1.20	.79	"	"	.52	"							

TUBE (INCHES)							TUBE (mm)						
DIA.	"E"	"F"	"G"	"H"	"J"	"K"	DIA.	"E"	"F"	"G"	"H"	"J"	"K"
1	1.45	1.04	.78	.20	.52	2.05	32	42	32.2	20	5	22.2	52
1 1/4	1.70	1.29	"	"	"	"	39	49	39.2	20	5	29.2	52
1 1/2	1.95	1.55	"	"	"	"	51	61	51.2	20	5	37.2	61
1 3/4	2.20	1.80	"	"	"	"	64	74	64.2	20	5	37.2	74
2	2.45	2.06	"	"	"	2.45	77	87	77.2	20	5	37.2	87
2 1/2	2.95	2.55	"	"	"	2.95							
3	3.45	3.06	"	"	"	3.45							

2 REQ' D EACH SIZE  
NYLON

FIG. 9 Nylon Electrode Support Detail

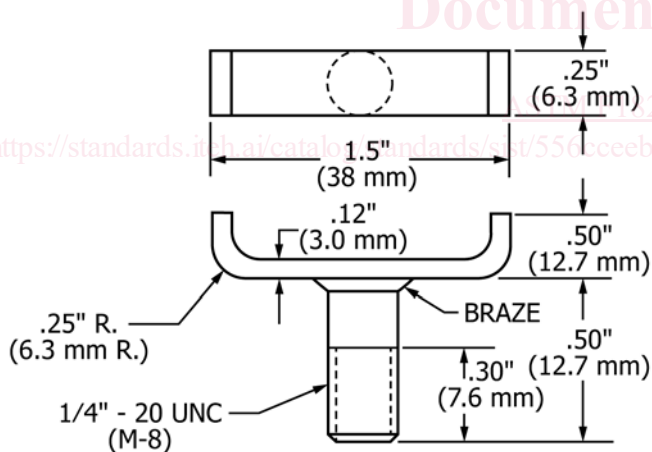

2 REQ'D BRASS  
FIG. 10 Brass Screw Detail

the tool. Without additional restraint, the deflection  $D$  at the top of the fully extended tool shall not exceed the values given in Table 2.

### 10. Electrical Design Test Specimen Preparation

10.1 Three telescoping tools shall each have a specimen cut from each telescoping section. Each specimen shall be 300 mm (12 in.) in length.

#### 10.2 Conditioning Prior to Electrical Tests:

10.2.1 Prior to the first or initial electrical test, the sample shall be cleaned inside and out with a suitable solvent, as recommended by the manufacturer, specifically a solvent that neither destroys the materials from which the tube is made nor leaves any residue on the surface of the sample.

10.2.2 All tests shall be made before and after exposure to moisture conditioning, as specified, using 60 Hz voltage.

#### 10.3 Moisture Conditioning:

10.3.1 Before Current Measurement —After initial cleaning (see 10.2.1), the specimen shall remain in the ambient atmosphere of the test premises for at least 24 h.

10.3.2 Upon completion of the before-moisture conditioning electrical test ( $I_1$ ), the specimen shall then be placed in a suitable chamber and undergo the following conditioning prior to the after-moisture conditioning electrical test, ( $I_2$ ). See Table 3.

### 11. Electrical Test Methods

11.1 Electrical Tests—The test apparatus shall be designed to provide the operator full protection in the performance of duties and provide reliable means of de-energizing and grounding the high-voltage circuit.

11.1.1 During the course of the testing, there shall be no sign of flashover or puncture on any of the samples.

11.1.2 The ambient temperature for the test location shall not be lower than 20 °C (68 °F).

11.2 Electrical Design Test—A typical test setup is shown in Fig. 4. Details are shown in Figs. 5-10. The measuring equipment should not be less than 1.8 m (6 ft) from the high-voltage electrode. Shield and ground the assembly of connection for the measuring equipment. Vertically mount the test specimen at least 0.9 m (3 ft) above the floor on an insulating support. Apply the voltage of 100 kV rms at 60 Hz between the electrodes, in accordance with Test Method D149 at a maximum voltage rise of 3000 V/s. Measure the current passing over or through the test specimen in rms values by passing it through a known resistance.

11.2.1 The current  $I_1$  is the maximum dielectric current measured with an alternating voltage of 100 kV rms 60 Hz applied between the electrodes for one minute.

11.2.2 After moisture conditioning and a light wiping with a dry cloth, the current  $I_2$  is measured under the same conditions as was  $I_1$ .

11.2.3 Locate the specimen in the same relative position to earth. The high-potential end of the sample shall be the same for both tests.

11.2.4 Test Results—The currents ( $I_1$ ) measured must be less than the values in Table 4. The difference between  $I_1$  and  $I_2$  shall be less than 20  $\mu$ A.

136.36 kg (300 lb) along its axis for 10 min without damage. The tool shall not elongate or show any sign of deterioration.

9.3.4 Vertical Deflection Test—The telescoping live line tool shall be placed vertically in a testing device such that the bottom section can be tilted. See Fig. 3. The tilt shall be 30.48 cm (12 in.) from vertical at 152 cm (60 in.) from the bottom of