



Designation: ~~D7248/D7248M – 12 (Reapproved 2017)~~ D7248/D7248M – 21

Standard Test Method for Bearing/Bypass-High Bearing - Low Bypass Interaction Response of Polymer Matrix Composite Laminates Using 2-Fastener Specimens¹

This standard is issued under the fixed designation D7248/D7248M; the number immediately following the designation indicates the year of original adoption or, in the case of revision, the year of last revision. A number in parentheses indicates the year of last reapproval. A superscript epsilon (ϵ) indicates an editorial change since the last revision or reapproval.

1. Scope

1.1 This test method determines the uniaxial bearing/bypass interaction response of multi-directional polymer matrix composite laminates reinforced by high-modulus fibers by either double-shear tensile loading (~~Procedures A and C~~)-(Procedure A) or single-shear tensile or compressive loading (Procedure B) of a two-fastener specimen. The scope of this test method is limited to net section (bypass) failure modes. Standard specimen configurations using fixed values of test parameters are described for each procedure. A number of test parameters may be varied within the scope of the standard, provided that the parameters are fully documented in the test report. The composite material forms are limited to continuous-fiber or discontinuous-fiber (tape or fabric, or both) reinforced composites for which the laminate is balanced and symmetric with respect to the test direction. The range of acceptable test laminates and thicknesses are described in 8.2.1. Test methods for high bypass - low bearing response of polymer matrix composite materials, previously published under Procedure C of this test method, are now published in Test Method D8387/D8387M.

1.2 This test method is consistent with the recommendations of ~~MIL-HDBK-17~~, Composite Materials Handbook, CMH-17, which describes the desirable attributes of a bearing/bypass interaction response test method.

1.3 The two-fastener test configurations described in this test method are similar to those in Test Method D5961/D5961M as well as those used by industry to investigate the bearing portion of the bearing/bypass interaction response for bolted joints, where the specimen may produce either a bearing failure mode or a bypass failure mode. Should the test specimen fail in a bearing failure mode rather than the desired bypass mode, then the test should be considered to be a bearing dominated bearing/bypass test, and the data reduction and reporting procedures of Test Method D5961/D5961M should be used instead of those given in this ~~standard-test method~~.

1.4 Units—The values stated in either SI units or inch-pound units are to be regarded separately as standard. The values stated in each system ~~may are not necessarily~~ exact equivalents; therefore, to ensure conformance with the standard, each system shall be used independently of the other. ~~Combining other, and~~ values from the two systems ~~may result in non-conformance with the standard; shall not be combined~~.

1.4.1 Within the text, the inch-pound units are shown in brackets.

1.5 *This standard does not purport to address all of the safety concerns, if any, associated with its use. It is the responsibility of the user of this standard to establish appropriate safety-safety, health, and healthenvironmental practices and determine the applicability of regulatory limitations prior to use.*

¹ This test method is under the jurisdiction of ASTM Committee D30 on Composite Materials and is the direct responsibility of Subcommittee D30.05 on Structural Test Methods.

Current edition approved ~~Aug. 1, 2017~~ May 15, 2021. Published ~~May 2017~~ June 2021. Originally approved in 2007. Last previous edition approved in ~~2012~~ 2017 as ~~D7248/D7248M~~ D7248/D7248M – 12-12 (2017). DOI: ~~10.1520/D7248-D7248M-12R17~~ 10.1520/D7248_D7248M-21.

1.6 This international standard was developed in accordance with internationally recognized principles on standardization established in the Decision on Principles for the Development of International Standards, Guides and Recommendations issued by the World Trade Organization Technical Barriers to Trade (TBT) Committee.

2. Referenced Documents

2.1 ASTM Standards:²

- D792 Test Methods for Density and Specific Gravity (Relative Density) of Plastics by Displacement
- D883 Terminology Relating to Plastics
- D2584 Test Method for Ignition Loss of Cured Reinforced Resins
- D2734 Test Methods for Void Content of Reinforced Plastics
- D3171 Test Methods for Constituent Content of Composite Materials
- D3878 Terminology for Composite Materials
- D5229/D5229M Test Method for Moisture Absorption Properties and Equilibrium Conditioning of Polymer Matrix Composite Materials
- D5687/D5687M Guide for Preparation of Flat Composite Panels with Processing Guidelines for Specimen Preparation
- D5766/D5766M Test Method for Open-Hole Tensile Strength of Polymer Matrix Composite Laminates
- D5961/D5961M Test Method for Bearing Response of Polymer Matrix Composite Laminates
- D6484/D6484M Test Method for Open-Hole Compressive Strength of Polymer Matrix Composite Laminates
- D6742/D6742M Practice for Filled-Hole Tension and Compression Testing of Polymer Matrix Composite Laminates
- D8387/D8387M Test Method for High Bypass – Low Bearing Interaction Response of Polymer Matrix Composite Laminates
- E4 Practices for Force Verification of Testing Machines
- E6 Terminology Relating to Methods of Mechanical Testing
- E83 Practice for Verification and Classification of Extensometer Systems
- E122 Practice for Calculating Sample Size to Estimate, With Specified Precision, the Average for a Characteristic of a Lot or Process
- E177 Practice for Use of the Terms Precision and Bias in ASTM Test Methods
- E251 Test Methods for Performance Characteristics of Metallic Bonded Resistance Strain Gages
- E456 Terminology Relating to Quality and Statistics
- E1237 Guide for Installing Bonded Resistance Strain Gages
- ~~E1309 Guide for Identification of Fiber-Reinforced Polymer Matrix Composite Materials in Databases (Withdrawn 2015)³~~
- ~~E1434 Guide for Recording Mechanical Test Data of Fiber-Reinforced Composite Materials in Databases (Withdrawn 2015)³~~

2.2 Other Document:³

~~ML-HDBK-17 Composite Materials Handbook, CMH-17 Polymer Matrix Composites, Volume 1, Section 7 Chapter 7~~
<https://standards.iteh.ai/catalog/standards/sist/532659ba-6e17-4daf-92fa-61665aad9e9d/astm-d7248-d7248m-21>

3. Terminology

3.1 *Definitions*—Terminology **D3878** defines terms relating to high-modulus fibers and their composites. Terminology **D883** defines terms relating to plastics. Terminology **E6** defines terms relating to mechanical testing. Terminology **E456** and Practice **E177** define terms relating to statistics. In the event of a conflict between terms, Terminology **D3878** shall have precedence over the other documents.

NOTE 1—If the term represents a physical quantity, its analytical dimensions are stated immediately following the term (or letter symbol) in fundamental dimension form, using the following ASTM standard symbology for fundamental dimensions, shown within square brackets: $[M]$ for mass, $[L]$ for length, $[T]$ for time, $[\theta]$ for thermodynamic temperature, and $[nd]$ for non-dimensional quantities. Use of these symbols is restricted to analytical dimensions when used with square brackets, as the symbols may have other definitions when used without the brackets.

3.2 Definitions of Terms Specific to This Standard:

~~3.2.1 gross bypass stress, $f_{gr\ bvp}^{[ML^{-1}T^{-2}],n}$ —the gross bypass stress for tensile loadings is calculated from the total force bypassing the fastener hole.~~

~~3.2.2 net bypass stress, $f_{net\ bvp}^{[ML^{-1}T^{-2}],n}$ —the net bypass stress for tensile loading is calculated from the force bypassing the fastener hole minus the force reacted in bearing at the fastener.~~

² For referenced ASTM standards, visit the ASTM website, www.astm.org, or contact ASTM Customer Service at service@astm.org. For *Annual Book of ASTM Standards* volume information, refer to the standard's Document Summary page on the ASTM website.

³ Available from Standardization Documents Order Desk, DODSSP, Bldg. 4, Section D, 700 Robbins Ave., Philadelphia, PA 19111-5098, <http://dodssp.daps.dla.mil>. SAE International (SAE), 400 Commonwealth Dr., Warrendale, PA 15096, <http://www.sae.org>.

NOTE 2—For compressive loadings the gross and net bypass stresses are equal and are calculated using the force that bypasses the fastener hole (since for the compressive loading case the bearing stress reaction is on the same side of the fastener as the applied force, the force reacted in bearing does not bypass the fastener hole).

NOTE 3—Several alternate definitions for gross and net bypass stress have been used historically in the aerospace industry. Comparison of data from tests conforming to this standard with historical data may need to account for differences in the bypass definitions.

3.2.1 *bearing area*, $[L^2], n$ —the area of that portion of a specimen used to normalize applied loading into an effective bearing stress; equal to the diameter of the fastener multiplied by the thickness of the specimen.

3.2.2 *bearing chord stiffness*, $E^{br} [ML^{-1}T^{-2}], n$ —the chord stiffness between two specific bearing stress or bearing strain points in the linear portion of the bearing stress/bearing strain curve.

3.2.3 *bearing force*, $P [MLT^{-2}], n$ —the in-plane force transmitted by a fastener to a specimen at the fastener hole.

3.2.4 *bearing strain*, $\epsilon,^{br} [nd], n$ —the normalized hole deformation in a specimen, equal to the deformation of the bearing hole in the direction of the bearing force, divided by the diameter of the hole.

3.2.5 *bearing strength*, $F_x^{br-byp} [ML^{-1}T^{-2}], n$ —the value of bearing stress occurring at the point of bypass (net section) failure.

3.2.6 *bearing stress*, $\sigma^{br} [ML^{-1}T^{-2}], n$ —the bearing force divided by the bearing area.

3.2.7 *diameter to thickness ratio*, $D/h [nd], n$ —in a bearing specimen, the ratio of the hole diameter to the specimen thickness.

3.2.7.1 *Discussion*—

The diameter to thickness ratio may be either a nominal value determined from nominal dimensions or an actual value determined from measured dimensions.

3.2.8 *edge distance ratio*, $e/D [nd], n$ —in a bearing specimen, the ratio of the distance between the center of the hole and the specimen end to the hole diameter.

3.2.8.1 *Discussion*—

The edge distance ratio may be either a nominal value determined from nominal dimensions or an actual value determined from measured dimensions.

3.2.9 *gross bypass stress*, $f^{gr-byp} [ML^{-1}T^{-2}], n$ —the gross bypass stress for tensile loadings is calculated from the total force bypassing the fastener hole.

3.2.10 *net bypass stress*, $f^{net-byp} [ML^{-1}T^{-2}], n$ —the net bypass stress for tensile loading is calculated from the force bypassing the fastener hole minus the force reacted in bearing at the fastener.

NOTE 2—For compressive loadings, the gross and net bypass stresses are equal and are calculated using the force that bypasses the fastener hole (since for the compressive loading case, the bearing stress reaction is on the same side of the fastener as the applied force, the force reacted in bearing does not bypass the fastener hole).

NOTE 3—Several alternate definitions for gross and net bypass stress have been used historically in the aerospace industry. Comparison of data from tests conforming to this test method with historical data may need to account for differences in the bypass definitions.

3.2.11 *nominal value*, n —a value, existing in name only, assigned to a measurable quantity for the purpose of convenient designation. Tolerances may be applied to a nominal value to define an acceptable range for the quantity.

3.2.12 *offset bearing strength*, $F_x^{bro} [ML^{-1}T^{-2}], n$ —the value of bearing stress, in the direction specified by the subscript, at the point where a bearing chord stiffness line, offset along the bearing strain axis by a specified bearing strain value, intersects the bearing stress/bearing strain curve.

3.2.12.1 *Discussion*—

Unless otherwise specified, an offset bearing strain of 2 % is to be used in this test method.

3.2.13 *width to diameter ratio, w/D [nd], n —in a bearing specimen, the ratio of specimen width to hole diameter.*

3.2.13.1 *Discussion—*

The width to diameter ratio may be either a nominal value determined from nominal dimensions or an actual value, determined as the ratio of the actual specimen width to the actual hole diameter.

3.2.13 *ultimate bearing strength, F_x^{bru} [ML⁻¹T⁻²], n —the value of bearing stress, in the direction specified by the subscript, at the maximum force capability of a bearing specimen.*

3.2.14 *ultimate gross bypass strength, $F_x^{gr_byp}$ [ML⁻¹T⁻²], n —the value of gross bypass stress, in the direction specified by the subscript, at the maximum force capability of the specimen.*

3.2.15 *ultimate net bypass strength, $F_x^{net_byp}$ [ML⁻¹T⁻²], n —the value of net bypass stress, in the direction specified by the subscript, at the maximum force capability of the specimen.*

3.2.16 *width to diameter ratio, w/D [nd], n —in a bearing specimen, the ratio of specimen width to hole diameter.*

3.2.16.1 *Discussion—*

The width to diameter ratio may be either a nominal value determined from nominal dimensions or an actual value, determined as the ratio of the actual specimen width to the actual hole diameter.

3.3 *Symbols:*

A = cross-sectional area of a specimen

CV = coefficient of variation statistic of a sample population for a given property (in percent)

d = fastener or pin diameter

D = specimen hole diameter

d_{csk} = countersink depth

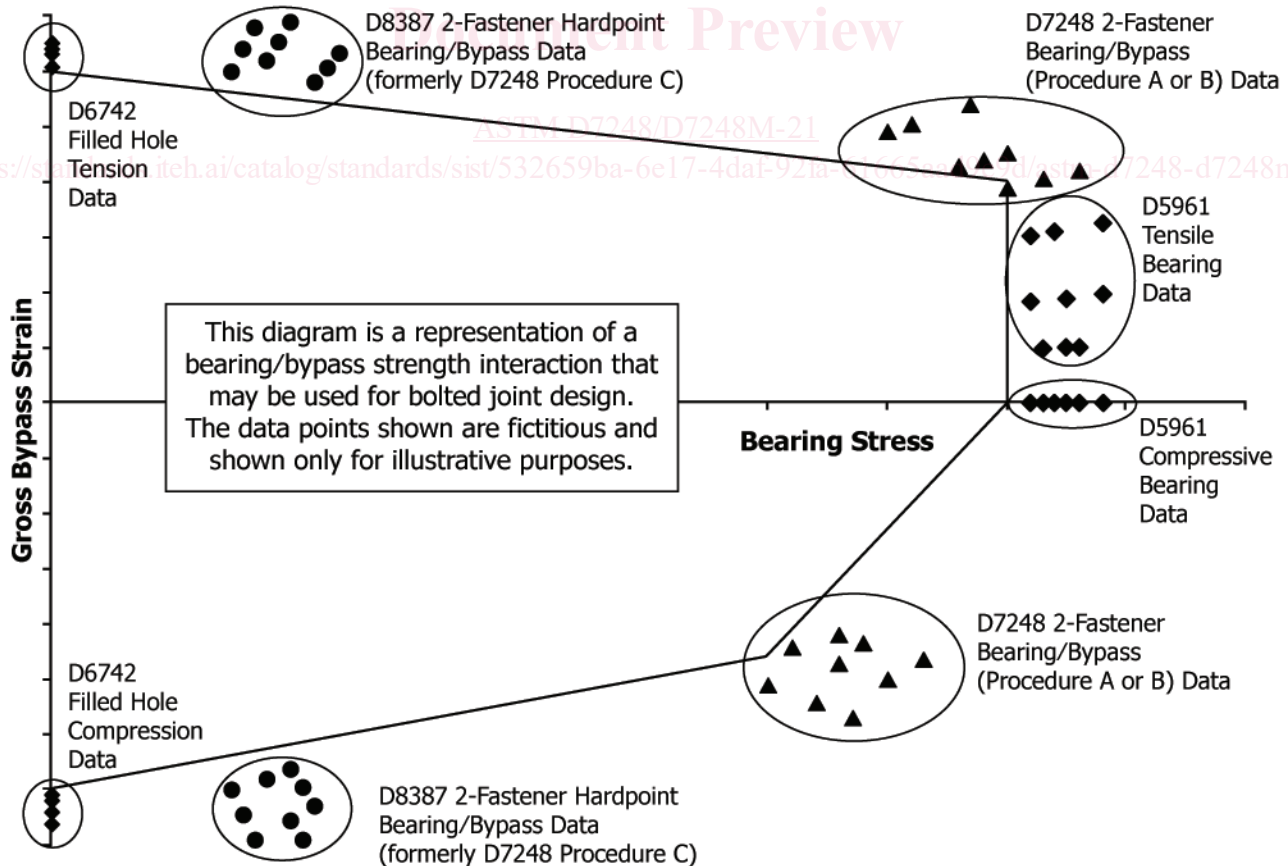

FIG. 1 Illustration of FHT, FHC, Bearing and Bearing/Bypass Bolted Joints Data and Bearing/Bypass Interaction Diagram (Refs 1-3)

d_g = countersink flushness (depth or protrusion of the fastener in a countersunk hole)

e = distance, parallel to applied force, from hole center to end of specimen; the edge distance

E_x^{br} = bearing chord stiffness in the test direction specified by the subscript

~~f = distance, parallel to applied force, from hole edge to end of specimen~~

$F_x^{br_byp}$ = bearing stress at the ultimate bypass strength in the test direction specified by the subscript

$F_x^{gr_byp-c}$ = ultimate compressive gross bypass strength in the test direction specified by the subscript

$F_x^{gr_byp-t}$ = ultimate tensile gross bypass strength in the test direction specified by the subscript

$F_x^{net_byp-c}$ = ultimate compressive net bypass strength in the test direction specified by the subscript

$F_x^{net_byp-t}$ = ultimate tensile net bypass strength in the test direction specified by the subscript

~~g = distance, perpendicular to applied force, from hole edge to shortest edge end of specimen~~

h = specimen thickness

~~k = calculation factor used in bearing equations to distinguish single fastener tests from double fastener tests~~
calculations to determine net force portion

L_g = extensometer gage length

n = number of specimens per sample population

P = force carried by test specimen

P^f = force carried by test specimen at failure

P^{max} = maximum force carried by test specimen prior to failure

s_{n-1} = standard deviation statistic of a sample population for a given property

w = specimen width

x_i = test result for an individual specimen from the sample population for a given property

\bar{x} = mean or average (estimate of mean) of a sample population for a given property

δ = extensional displacement

ϵ = general symbol for strain, whether normal strain or shear strain

ϵ^{br} = bearing strain

σ^{br} = bearing stress

~~w = specimen width~~

~~d_{csk} = countersink depth~~

~~d_g = countersink flushness (depth or protrusion of the fastener in a countersunk hole)~~

4. Summary of Test Method

4.1 *Bearing/Bypass Procedures*—Definition of the uniaxial bearing/bypass interaction response requires data for varying amounts of bearing and bypass forces at a fastener hole. Fig. 1 shows a typical composite laminate bearing/bypass interaction diagram (Refs 1-3),⁴ along with illustrative data from various test types. Data from Practice D6742/D6742M and Test Method D5961/D5961M define the 100 % bypass and bearing ends of the interaction diagram. Rationale for the baseline bearing/bypass specimen geometry and fastener torques are given in 6.7 and 6.8. Procedures A and B of this test method provide data in the bypass/high bearing region, while Procedure C provides tests per Test Method D8387/D8387M provide data in the bypass/low bearing region. More complicated test setups have been used to develop data across the full range of bearing/bypass interaction. This test method is limited to cases where the bearing and bypass loads are aligned in the same direction. It is also limited to uniaxial tensile or compressive bypass loads. Test procedures for cases where the bearing and bypass loads act at different directions, or cases with biaxial or shear bypass loads are outside the scope of this standard test method.

4.1.1 Ultimate strength for all procedures is calculated based on the specimen gross cross-sectional area, disregarding the presence of the hole. While the hole causes a stress concentration and reduced net section, it is common industry practice to develop notched design allowable strengths based on gross section stress to account for various stress concentrations (fastener holes, free edges, flaws, damage, and so forth) not explicitly modeled in the stress analysis. This is consistent with the ASTM D30 test methods for open and filled hole tension and compression strength (Test Methods D5766/D5766M, D6484/D6484M, and Practice D6742/D6742M).

4.2 Procedure A, Bypass/High Bearing Double Shear:

4.2.1 A flat, constant rectangular cross-section test specimen with two centerline holes located near the end of the specimen, as shown in the test specimen drawings of Figs. 2 and 3, is loaded at the hole in bearing. The bearing force is normally applied through a close-tolerance, lightly torqued fastener (or pin) that is reacted in double shear by a fixture similar to that shown in Figs. 4 and

⁴ The boldface numbers in parentheses refer to the list of references at the end of this standard.

DRAWING NOTES:

1. INTERPRET DRAWING IN ACCORDANCE WITH ANSI Y14.5M-1982, SUBJECT TO THE FOLLOWING:
2. ALL DIMENSIONS IN MM WITH DECIMAL TOLERANCES AS FOLLOWS:
 NO DECIMAL .X .XX X
 +/-3 +/-1 +/- .3
3. ALL ANGLES HAVE TOLERANCE OF +/- .5°
4. PLY ORIENTATION DIRECTION TOLERANCE RELATIVE TO -A- WITHIN +/- .5°.
5. FINISH ON MACHINED EDGES NOT TO EXCEED $\sqrt{1.6}$ SYMBOLY IN ACCORDANCE WITH ASA B46.1, WITH ROUGHNESS HEIGHT IN MICROMETRES.)
6. VALUES TO BE PROVIDED FOR THE FOLLOWING, SUBJECT TO ANY RANGES SHOWN ON THE FIELD OF DRAWING; MATERIAL, LAY-UP, PLY ORIENTATION REFERENCE RELATIVE TO -A-, OVERALL LENGTH, HOLE DIAMETER, COUNTERSINK DETAILS, COUPON THICKNESS.

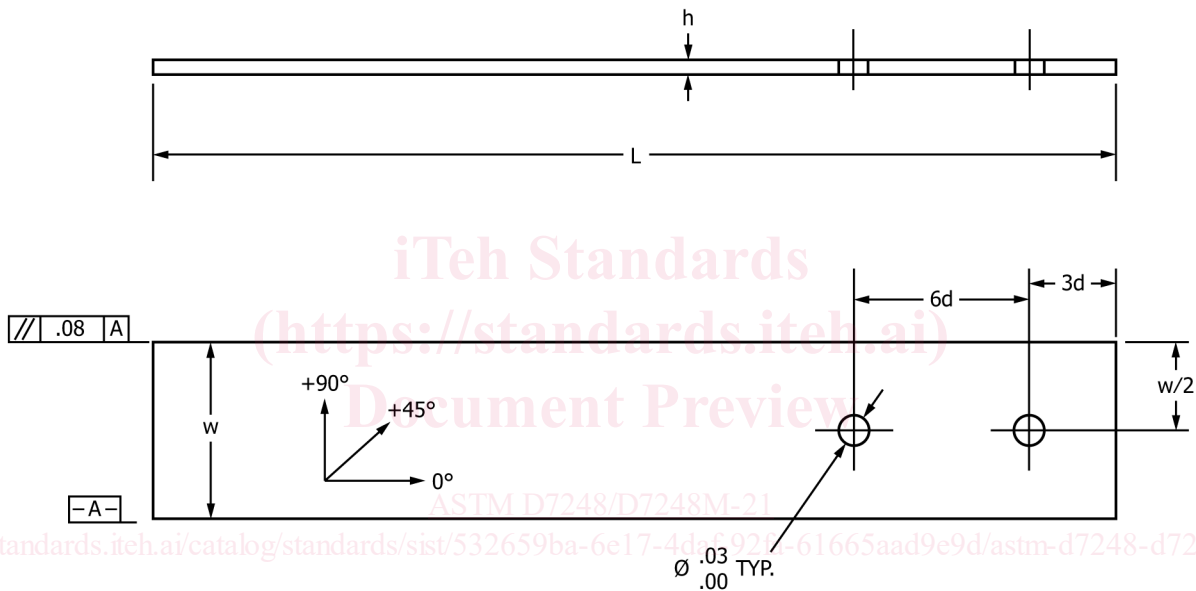

Parameters	Standard Dimensions (mm)
fastener diameter, d	6+0.00/-0.03
hole diameter, Ø	6+0.03/-0.00
thickness range, h	2-5
length, L	200
width, w	30+/-1
edge distance, e	18+/-1
countersink	none

FIG. 2 Double-Shear, Two-Fastener Test Specimen Drawing (SI)

5. The bearing force is created by pulling the assembly in tension in a testing machine. The difference from a standard “bearing” test is that the expected primary failure mode is net section tension, rather than a bearing mode.

4.2.2 Both the applied force and the associated deformation of the hole are monitored. The applied force is normalized by the projected hole area to create an effective bearing stress. The specimen is loaded until a two part failure is achieved.

DRAWING NOTES:

1. INTERPRET DRAWING IN ACCORDANCE WITH ANSI Y14.5M–1982, SUBJECT TO THE FOLLOWING:
2. ALL DIMENSIONS IN INCHES WITH DECIMAL TOLERANCES AS FOLLOWS:

.X	.XX	.XXX
+/- .1	+/- .03	+/- .003
3. ALL ANGLES HAVE TOLERANCE OF +/- .5°.
4. PLY ORIENTATION DIRECTION TOLERANCE RELATIVE TO -A- WITHIN +/- .5°.
5. FINISH ON MACHINED EDGES NOT TO EXCEED $\sqrt{64}$ SYMBOLY IN ACCORDANCE WITH ASA B46.1, WITH ROUGHNESS HEIGHT IN MICROINCHES.)
6. VALUES TO BE PROVIDED FOR THE FOLLOWING, SUBJECT TO ANY RANGES SHOWN ON THE FIELD OF DRAWING; MATERIAL, LAY-UP, PLY ORIENTATION REFERENCE RELATIVE TO -A-, OVERALL LENGTH, HOLE DIAMETER, COUNTERSINK DETAILS, COUPON THICKNESS.

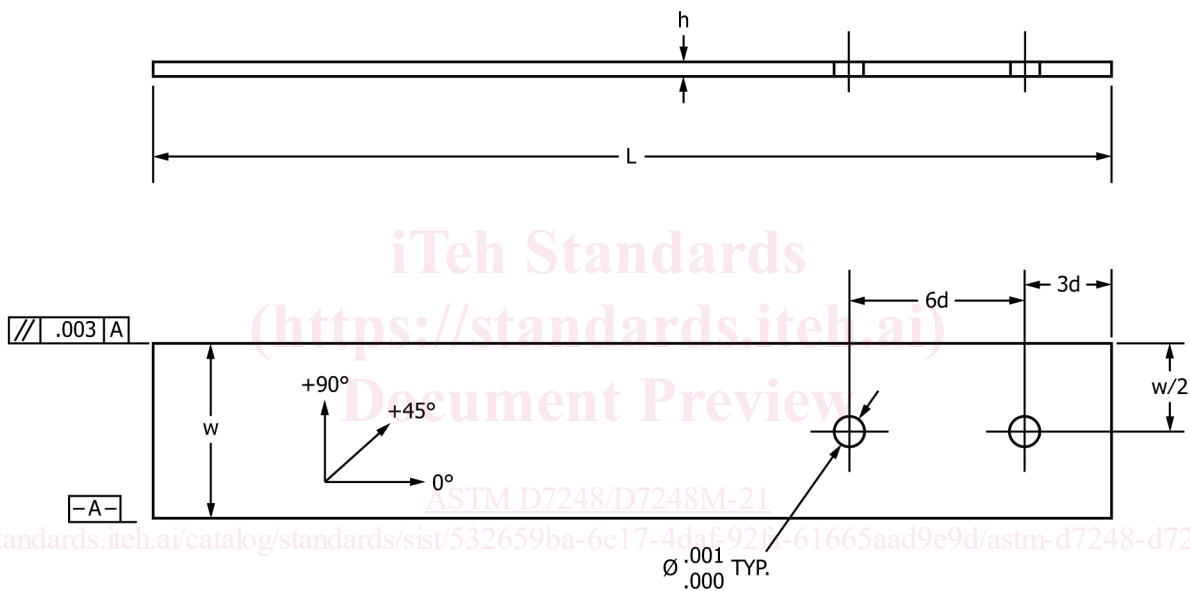

Parameters	Standard Dimensions (inches)
fastener diameter, d	0.250+0.000/-0.001
hole diameter, \emptyset	0.250+0.001/-0.000
thickness range, h	0.080-0.208
length, L	8.00
width, w	1.25+/-0.03
edge distance, e	0.75+/-0.03
countersink	none

FIG. 3 Double-Shear, Two-Fastener Test Specimen Drawing (Inch-Pound)

NOTE 4—Should the test specimen fail in a bearing failure mode rather than the desired bypass (net tension or compression) mode, then the test should be considered to be a bearing dominated bearing/bypass test, and the data reduction and reporting procedures of Test Method D5961/D5961M should be used instead of those given in this standard test method.

4.2.3 The standard test configuration for this procedure has defined values for the major test parameters. However, the following

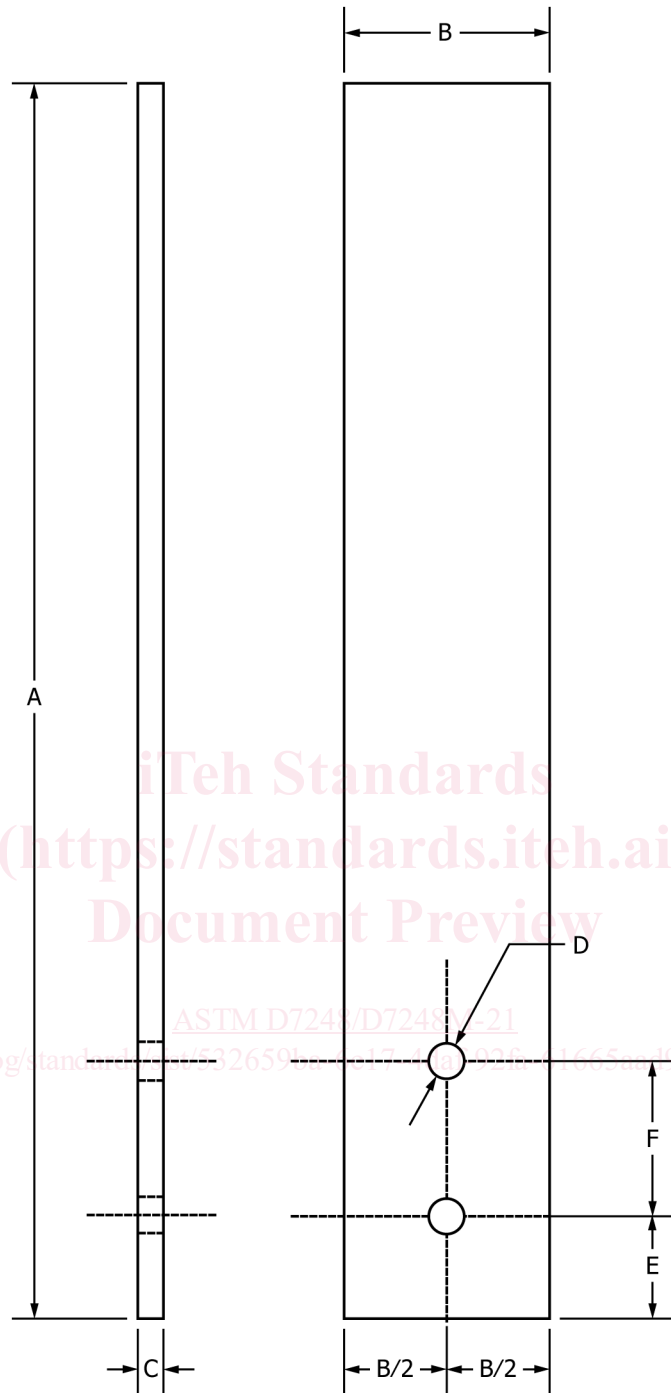

Recommended Material: 17-4PH Stainless Steel 1 GPa [145 ksi] yield stress						
	A	B	C	D	E	F
mm	200	30	3	6	18	36
inch	8.00	1.25	0.12	0.25	0.75	1.50

FIG. 4 Fixture Loading Plate for Procedure A (2 Required)

variations in configuration are allowed and can be considered as being in accordance with this test method as long as the values of all variant test parameters are prominently documented with the results.

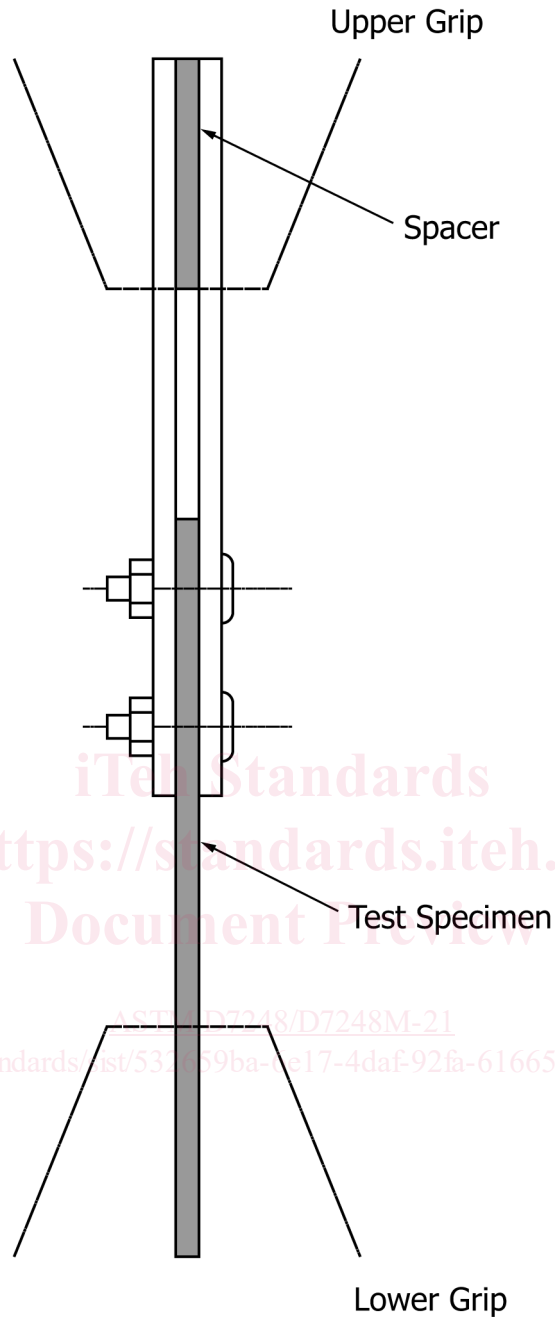

FIG. 5 Fixture Assembly for Procedure A

ASTM D7248/D7248M-21
<https://standards.iteh.ai/catalog/standards/st/532/59ba-c0e17-4daf-92fa-61665aad9e9d/astm-d7248-d7248m-21>

Parameter	Standard	Variation
Loading condition	double-shear	none
Loading type	tensile	none
Mating material	steel fixture	any, if documented
Number of holes	2	3
Countersink	none	none
Hole fit	tight	any, if documented
Fastener torque	9.0-10.7 N·m [90-95 lbf-in.]	any, if documented
Laminate	quasi-isotropic	any, if documented
Fastener diameter	6 mm [0.250 in.]	any, if documented
Edge distance ratio	3	any, if documented
w/D ratio	5	any, if documented
D/h ratio	1.2-2	any, if documented

4.3 Procedure B, Bypass/High Bearing Single Shear:

4.3.1 The flat, constant rectangular cross-section test specimen is composed of two like halves fastened together through two centerline holes located near one end of each half, as shown in the test specimen drawings of Figs. 6 and 7. The eccentricity in applied force that would otherwise result is minimized by a doubler bonded to each grip end of the specimen, resulting in a force line-of-action along the interface between the specimen halves, through the centerline of the hole(s).

4.3.1.1 *Unstabilized Configuration (No Support Fixture)*—The ends of the test specimen are gripped in the jaws of a test machine and loaded in tension.

4.3.1.2 *Stabilized Configuration (Using Support Fixture)*—The test specimen is face-supported in a multi-piece bolted support fixture, as shown in Fig. 8. The test specimen/fixture assembly is clamped in hydraulic wedge grips and the force is sheared into the support fixture and then sheared into the specimen. Either tensile or compressive force may be applied. The stabilization fixture is required for compressive loading. For tensile loading, the fixture is optional, but is often used to simulate actual stabilized joint configurations.

- DRAWING NOTES:
1. INTERPRET DRAWING IN ACCORDANCE WITH ANSI Y14.5M-1982, SUBJECT TO THE FOLLOWING:
 2. ALL DIMENSIONS IN MM WITH DECIMAL TOLERANCES AS FOLLOWS:
 NO DECIMAL .X .XX X
 +/-3 +/-1 +/-3
 3. ALL ANGLES HAVE TOLERANCE OF +/- .5°.
 4. PLY ORIENTATION DIRECTION TOLERANCE RELATIVE TO -A- WITHIN +/- .5°.
 5. FINISH ON MACHINED EDGES NOT TO EXCEED $\sqrt{1.6}$ SYMBOLOGY IN ACCORDANCE WITH ASA B46.1, WITH ROUGHNESS HEIGHT IN MICROMETRES.)
 6. VALUES TO BE PROVIDED FOR THE FOLLOWING, SUBJECT TO ANY RANGES SHOWN ON THE FIELD OF DRAWING; MATERIAL, LAY-UP, PLY ORIENTATION REFERENCE RELATIVE TO -A-, OVERALL LENGTH, HOLE DIAMETER, COUNTERSINK DETAILS, COUPON THICKNESS, DOUBLER MATERIAL, DOUBLER ADHESIVE.

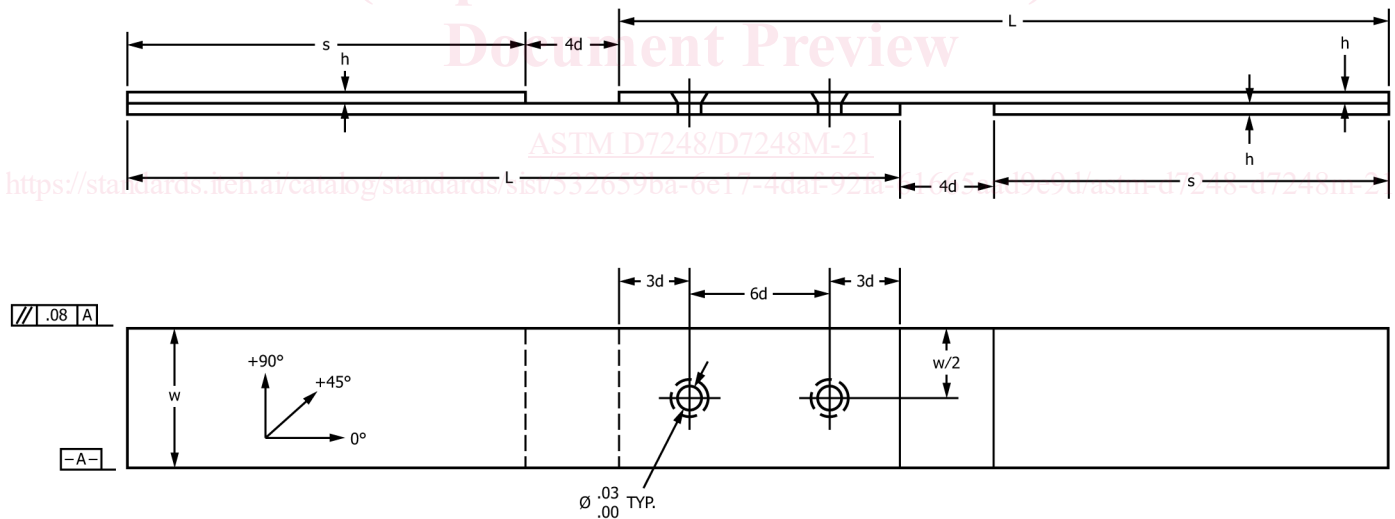

Parameters	Standard Dimensions of Specimen (mm)	
	without support fixture	with support fixture
fastener diameter, d	6 + 0.00/-0.03	6 + 0.00/-0.03
hole diameter, Ø	6 + 0.03/-0.00	6 + 0.03/-0.00
thickness range, h	2-5	2-5
length, L	210	210
width, w	30 +/- 1	30 +/- 1
edge distance, e	18 +/- 1	18 +/- 1
countersink	none (optional)	none (optional)
doubler length, s	108	108

FIG. 6 Single-Shear, Two-Fastener Test Specimen Drawing (SI)

DRAWING NOTES:

1. INTERPRET DRAWING IN ACCORDANCE WITH ANSI Y14.5M-1982, SUBJECT TO THE FOLLOWING:
2. ALL DIMENSIONS IN INCHES WITH DECIMAL TOLERANCES AS FOLLOWS:

.X	.XX	.XXX
+/- .1	+/- .03	+/- .003
3. ALL ANGLES HAVE TOLERANCE OF +/- .5°.
4. PLY ORIENTATION DIRECTION TOLERANCE RELATIVE TO -A- WITHIN +/- .5°.
5. FINISH ON MACHINED EDGES NOT TO EXCEED $\sqrt{64}$ SYMBOLY IN ACCORDANCE WITH ASA B46.1, WITH ROUGHNESS HEIGHT IN MICROINCHES.)
6. VALUES TO BE PROVIDED FOR THE FOLLOWING, SUBJECT TO ANY RANGES SHOWN ON THE FIELD OF DRAWING; MATERIAL, LAY-UP, PLY ORIENTATION REFERENCE RELATIVE TO -A-, OVERALL LENGTH, HOLE DIAMETER, COUNTERSINK DETAILS, COUPON THICKNESS, DOUBLER MATERIAL, DOUBLER ADHESIVE.

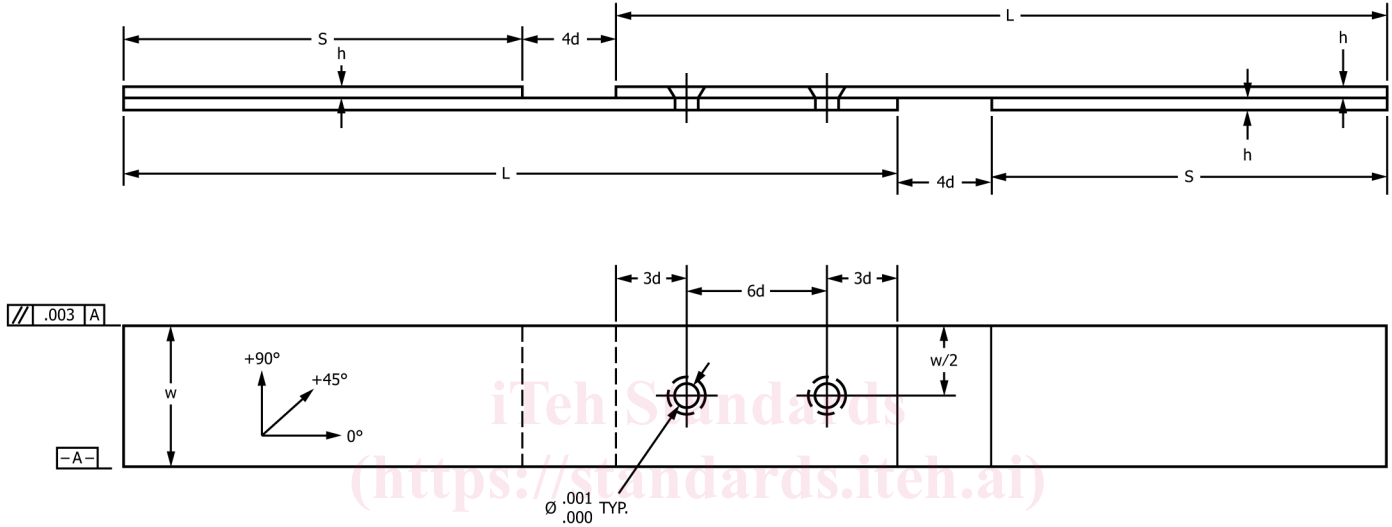

Parameters	Standard Dimensions of Specimen (inches)	
	without support fixture	with support fixture
fastener diameter, d	0.250+0.000/-0.001	0.250+0.000/-0.001
hole diameter, Ø	0.250+0.001/-0.000	0.250+0.001/-0.000
thickness range, h	0.080-0.208	0.080-0.208
length, L	8.25	8.25
width, w	1.25+/-0.03	1.25+/-0.03
edge distance, e	0.75+/-0.03	0.75+/-0.03
countersink	none (optional)	none (optional)
doubler length, s	4.25	4.25

FIG. 7 Single-Shear, Two-Fastener Test Specimen Drawing (Inch-Pound)

4.3.2 Both the applied force and the associated deformation of the hole(s) are monitored. The applied force is normalized by the projected hole area to yield an effective bearing stress. The specimen is loaded until a two part failure is achieved.

NOTE 5—Should the test specimen fail in a bearing failure mode rather than the desired net tension or compression, then the test should be considered to be a bearing dominated bearing/bypass test, and the data reduction and reporting procedures of Test Method D5961/D5961M should be used instead of those given in this standard test method.

4.3.3 The standard test configuration for this procedure has defined values for the major test parameters. However, the following variations in configuration are allowed and can be considered as being in accordance with this test method as long as the values of all variant test parameters are prominently documented with the results.

Parameter	Standard	Variation
Loading condition	single-shear	none
Loading type	tensile	compressive

METRIC HARDWARE
 NA0036-060029 BOLT (4)
 NA0179B-060 WASHER (8 +)
 (NO. AS REQUIRED)
 NA033-060M NUT (4)
 (OR EQUIVALENT)
 OR FOR THREADED PLATES
 NA0036-060027 BOLT (4)
 NA0179B-060 WASHER (4)
 (OR EQUIVALENT)

U.S. CUSTOMARY HARDWARE
 NAS6604-22 BOLT
 NAS1149DO463J WASHER (8+)
 (NO. AS REQUIRED)
 MS21042L4 NUT (4)
 (OR EQUIVALENT)
 OR FOR THREADED PLATES
 NAS6604-18 BOLT (4)
 NAS1149DO463J WASHER (4)
 (OR EQUIVALENT)

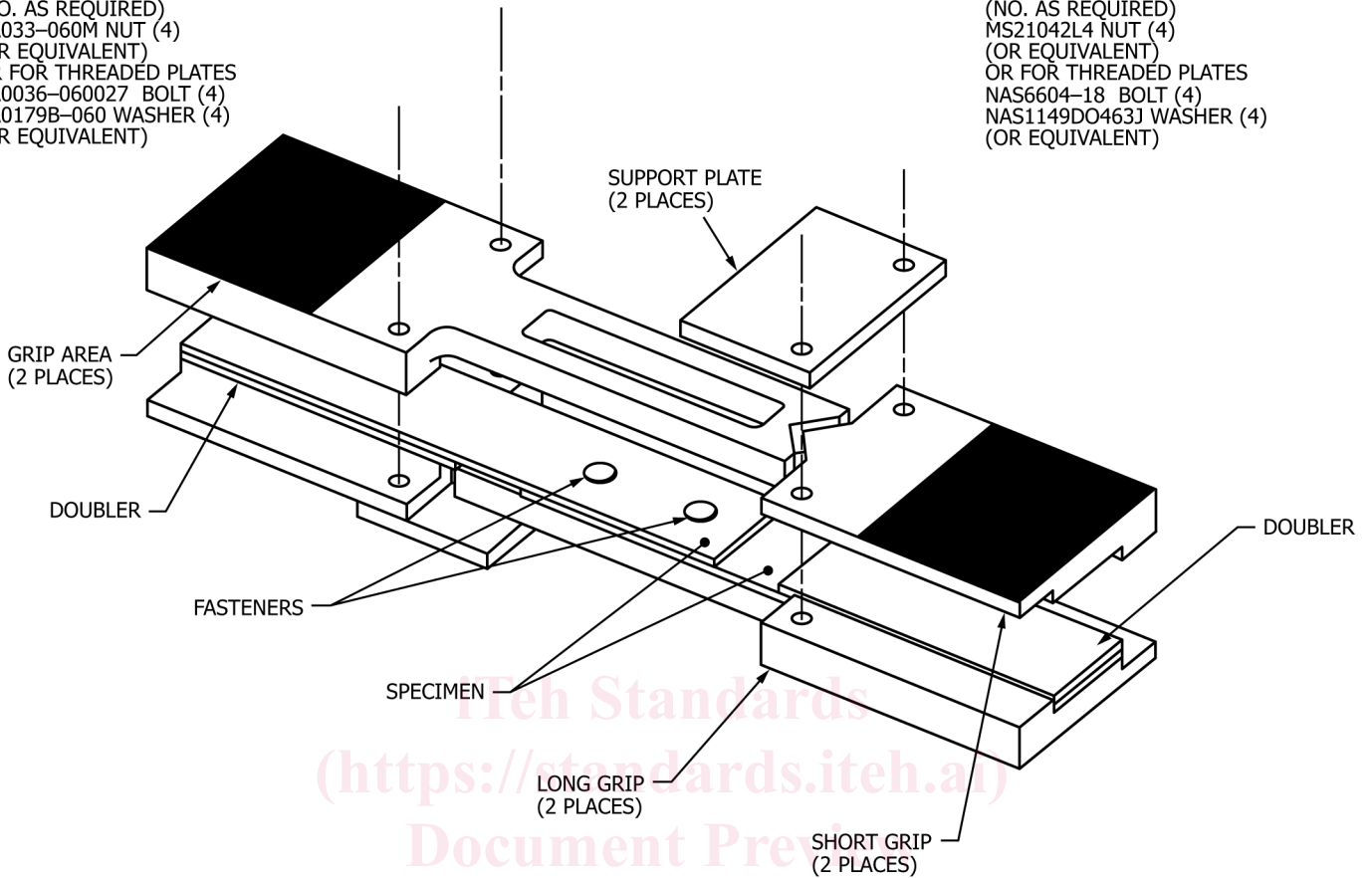

FIG. 8 Support Fixture Assembly for Procedure B (for details of the Support Fixture, see Test Method D5961/D5961M)

ASTM D7248/D7248M-21

<https://standards.iteh.ai/catalog/standards/sist/532659ba-6e17-4daf-92fa-61665aad9e9d/astm-d7248-d7248m-21>

Parameter	Standard	Variation
Support fixture	no for tensile load yes for compressive load	yes, if documented
Number of holes	2	3
Countersunk holes	no	yes, if documented
Grommets	no	yes, if documented
Mating material	same laminate	any, if documented
Hole fit	tight	any, if documented
Fastener torque	9.0-10.7 N·m [80-95 lbf-in.] for tensile load 2.2-3.4 N·m [20-30 lbf-in.] for compressive load	any, if documented
Laminate	quasi-isotropic	any, if documented
Fastener diameter	6 mm [0.250 in.]	any, if documented
Edge distance ratio	3	any, if documented
w/D ratio	5	any, if documented
D/h ratio	1.2-2	any, if documented

4.4 Procedure C, Bypass/Low Bearing Double Shear:

4.4.1 A flat, constant rectangular cross-section test specimen with two centerline holes located in the middle of the specimen, as shown in the test specimen drawing of Fig. 9. Two doubler plates, Fig. 10, are attached to the specimen as shown in Fig. 11 to act as a “hardpoint” which induces bearing forces in the test specimen and plates. The ends of the test specimen are gripped in the jaws of a test machine and loaded in tension or compression.

4.4.1.1 *Unstabilized Configuration (No Support Fixture)*—The ends of the test specimen are gripped in the jaws of a test machine and loaded in tension.