



Designation: **C1610/C1610M—19** C1610/C1610M – 21

Standard Test Method for Static Segregation of Self-Consolidating Concrete Using Column Technique¹

This standard is issued under the fixed designation C1610/C1610M; the number immediately following the designation indicates the year of original adoption or, in the case of revision, the year of last revision. A number in parentheses indicates the year of last reappraisal. A superscript epsilon (ϵ) indicates an editorial change since the last revision or reappraisal.

1. Scope*

1.1 This test method covers the determination of static segregation of self-consolidating concrete (SCC) by measuring the coarse aggregate content in the top and bottom portions of a cylindrical specimen (or column).

1.2 This test method is not applicable to self-consolidating concrete containing lightweight aggregate.

1.3 This test method is applicable under laboratory and field conditions.

1.4 The values stated in either SI units or inch-pound units are to be regarded separately as standard. The values stated in each system may not be exact equivalents; therefore, each system shall be used independently of the other. Combining values from the two systems may result in non-conformance with the standard.

1.5 The text of this standard references notes and footnotes that provide explanatory material. These notes and footnotes (excluding those in tables and figures) shall not be considered as requirements of the standard.

1.6 *This standard does not purport to address all of the safety concerns, if any, associated with its use. It is the responsibility of the user of this standard to establish appropriate safety, health, and environmental practices and determine the applicability of regulatory limitations prior to use. (Warning—Fresh hydraulic cementitious mixtures are caustic and may cause chemical burns to skin and tissue upon prolonged exposure.²)*

1.7 *This international standard was developed in accordance with internationally recognized principles on standardization established in the Decision on Principles for the Development of International Standards, Guides and Recommendations issued by the World Trade Organization Technical Barriers to Trade (TBT) Committee.*

2. Referenced Documents

2.1 *ASTM Standards:*³

[C125 Terminology Relating to Concrete and Concrete Aggregates](#)

[C127 Test Method for Relative Density \(Specific Gravity\) and Absorption of Coarse Aggregate](#)

[C172/C172M Practice for Sampling Freshly Mixed Concrete](#)

[C173/C173M Test Method for Air Content of Freshly Mixed Concrete by the Volumetric Method](#)

¹ This test method is under the jurisdiction of ASTM Committee C09 on Concrete and Concrete Aggregates and is the direct responsibility of Subcommittee C09.47 on Self-Consolidating Concrete.

Current edition approved June 15, 2019; May 15, 2021. Published August 2019; June 2021. Originally approved in 2006. Last previous edition approved in 2017 as C1610/C1610M – 17; 19. DOI: 10.1520/C1610-C1610M-19-10.1520/C1610_C1610M-21.

² Section on Safety Precautions, Manual of Aggregate and Concrete Testing, *Annual Book of ASTM Standards*, Vol 04.02.

³ For referenced ASTM standards, visit the ASTM website, www.astm.org, or contact ASTM Customer Service at service@astm.org. For *Annual Book of ASTM Standards* volume information, refer to the standard's Document Summary page on the ASTM website.

*A Summary of Changes section appears at the end of this standard

C192/C192M Practice for Making and Curing Concrete Test Specimens in the Laboratory
C231/C231M Test Method for Air Content of Freshly Mixed Concrete by the Pressure Method
C1712 Test Method for Rapid Assessment of Static Segregation Resistance of Self-Consolidating Concrete Using Penetration Test
C1758/C1758M Practice for Fabricating Test Specimens with Self-Consolidating Concrete
D1785 Specification for Poly(Vinyl Chloride) (PVC) Plastic Pipe, Schedules 40, 80, and 120

3. Terminology

3.1 Definitions:

3.1.1 For definitions of terms used in this test method, refer to Terminology **C125**.

3.2 Definitions of Terms Specific to This Standard:

3.2.1 *static segregation, n*—settlement of coarse aggregate particles in an undisturbed mass of fresh concrete.

4. Summary of Test Method

4.1 A sample of freshly-mixed self-consolidating concrete is placed in a cylindrical mold without tamping or vibration. The mold is separated into three sections representing different levels of the cylindrical specimen (or column). Portions of SCC from the top and bottom section are washed on a 4.75 mm (No. 4) sieve, leaving the coarse aggregate on the sieve. The masses of coarse aggregate in the top and the bottom sections are determined and the percent static segregation is calculated.

5. Significance and Use

5.1 This test method provides users with a procedure to determine the potential static segregation of self-consolidating concrete.

NOTE 1—This test method may not be sufficiently rapid to evaluate self-consolidating concrete mixtures in the field before placement. Test Method **C1712** provides a rapid method for assessing static segregation resistance of self-consolidating concrete.

5.2 This test method shall be used to develop self-consolidating concrete mixtures with segregation not exceeding specified limits. Self-consolidating concrete is a fluid concrete that can be prone to segregation if not proportioned to be cohesive. A cohesive self-consolidating concrete is important for all applications but is especially critical for deep-section applications such as walls or columns. Therefore, the degree of segregation can indicate if a mixture is suitable for the application.

<https://standards.iteh.ai/catalog/standards/sist/b7ce3a34-8877-4022-af43-b9fcfccded4b/astm-c1610-c1610m-21>

NOTE 2—Some level of segregation is tolerable as long as the desired strength and durability performance is achieved.

6. Apparatus

6.1 *Balance*—as described in Test Method **C127**.

6.2 *Column Mold*—The column portion of the mold shall be poly(vinyl chloride) (PVC) plastic pipe Schedule 40 meeting the requirements of Specification **D1785**. The column shall be 200 mm [8 in.] in nominal diameter by 660 mm [26 in.] in height and separated into 3 sections. The top section shall be 165 mm [6.5 in.] in height, the middle section 330 mm [13 in.] in height, and the bottom section 165 mm [6.5 in.] in height, as shown in **Fig. 1**. Each section shall have its ends flat and plane and be marked as “Top”, “Middle”, or “Bottom” relative to its location in the column. Couplers, brackets, clamps, or other equivalent fastening systems shall be used for securing the column sections together to form a mortar-tight joint and to secure the column to the base plate. The column mold shall be securely attached to a non-absorbent, rigid base plate measuring at least 300 mm [12 in.] by 300 mm [12 in.] square.

NOTE 3—Experience has shown that a base plate made from sealed or laminated plywood at least 20 mm [0.75 in.] thick is suitable for securing the column.

6.3 *Collector Plate*—The collector plate, used to obtain SCC from the top section of the column, shall be made of any nonabsorbent, rigid material measuring at least 510 mm [20 in.] by 510 mm [20 in.] square. The plate shall contain a cutout section in the center measuring 220 mm [8.7 in.] across and it shall contain a rigid lip that is at least 50 mm [2 in.] high running around three sides of the perimeter of the plate, as shown in **Fig. 2**.

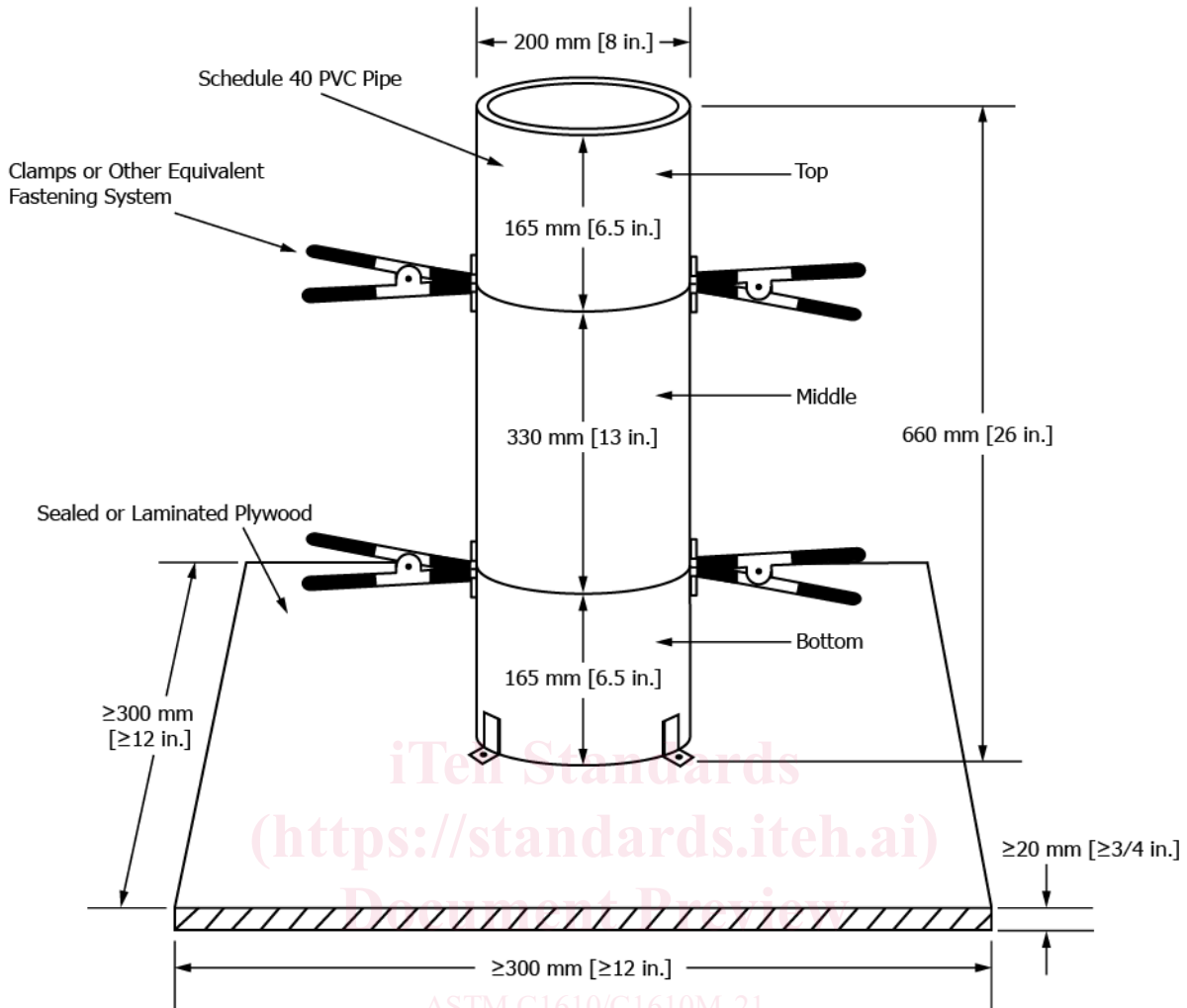

FIG. 1 Detail of Column Mold

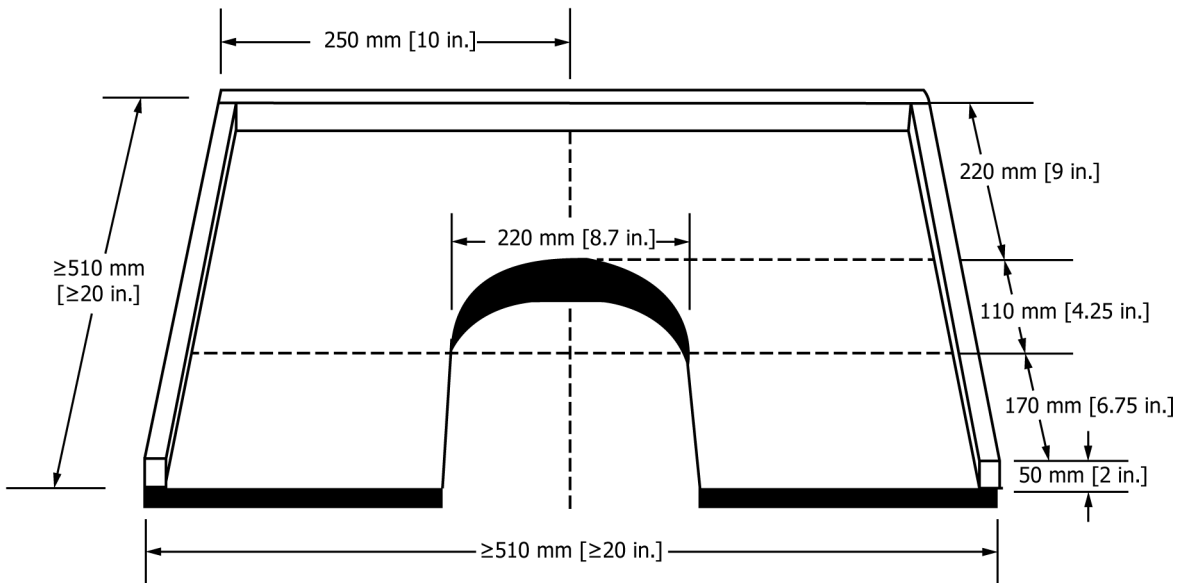

FIG. 2 Detail of Collector Plate

NOTE 4—To facilitate the ease with which the test can be performed, the collector plate may contain legs or another support system so that only one person

is needed to perform the SCC collection process from the top section.

6.4 *Strike-off Bar*—As described in Test Method [C173/C173M](#) or Test Method [C231/C231M](#).

6.5 *Sieve*—A 4.75 mm (No. 4) rectangular sieve with minimum dimensions of 330 mm [13 in.] by 630 mm [25 in.].

6.6 *Sample Receptacle*—A pan or wheelbarrow that is water-tight, has a nonabsorbent surface, and is large enough to allow both remixing of the entire sample and retain a volume of SCC sufficient to fill the column mold.

6.7 *Other Tools*—Items such as shovels and scoops capable of remixing the SCC in the sample receptacle, filling the pouring vessel, or both.

7. Sample

7.1 Obtain a sample of freshly-mixed self-consolidating concrete in accordance with Practice [C172/C172M](#) in the field or Practice [C192/C192M](#) in the laboratory, and place it in the sample receptacle.

8. Procedure

8.1 Perform this test on a flat, level work surface. Do not subject the work surface or the column mold to vibration or disturbance.

8.2 *Remixing of Sample*: Remix the sample obtained in accordance with [7.1](#) in the sample receptacle using a shovel or scoop so that the SCC is homogeneous.

8.3 Dampen the interior of the mold, removing any standing water on the base plate within the column.

8.4 Fill the mold with SCC in accordance with Practice [C1758/C1758M](#). Completely fill the mold within 2 min.

8.5 After filling the mold, strike off the top surface by sliding the strike-off bar across the top rim of the mold with a sawing motion until the SCC surface is level with the top of the mold.

8.6 Allow the SCC to stand undisturbed in the mold for 15 ± 1 min.

8.7 *Obtaining Section Samples*—Following the 15-min standing period in [8.6](#), a maximum of 20 min is allowed to complete [8.8](#) through [8.16](#).

8.8 Immediately following the standing period, securely hold the top section of the mold and remove the fastening system.

8.9 Place the cutout section of the collector plate around the column just below the joint between the “Top” and “Middle” sections to catch and collect SCC.

8.10 Grasp the upper section of the mold and, using a horizontal rotating motion, screed the SCC in the top section of the column on to the collector plate and then deposit it into a plastic pail.

8.11 Repeat Steps [8.8](#) – [8.10](#) to remove the SCC from the middle section of the mold. Discard this SCC.

8.12 Place the SCC sample collected from the upper section of the mold onto the 4.75 mm (No. 4) sieve.

8.13 Wash the SCC on the 4.75 mm (No. 4) sieve so that only coarse aggregate remains on the sieve. Deposit the coarse aggregate into a clean plastic pail.

8.14 Repeat Steps [8.12](#) and [8.13](#) for the SCC retained in the bottom section of the mold.