

INTERNATIONAL STANDARD

NORME INTERNATIONALE



Digital video interface – Gigabit video interface for multimedia systems

Interface vidéo numérique – Interface vidéo gigabit pour les systèmes multimédias

Document Preview

[IEC 62889:2024](#)

<https://standards.iteh.ai/catalog/standards/iec/901e3018-e094-407b-af8b-411dc1d6cca1/iec-62889-2024>



THIS PUBLICATION IS COPYRIGHT PROTECTED

Copyright © 2024 IEC, Geneva, Switzerland

All rights reserved. Unless otherwise specified, no part of this publication may be reproduced or utilized in any form or by any means, electronic or mechanical, including photocopying and microfilm, without permission in writing from either IEC or IEC's member National Committee in the country of the requester. If you have any questions about IEC copyright or have an enquiry about obtaining additional rights to this publication, please contact the address below or your local IEC member National Committee for further information.

Droits de reproduction réservés. Sauf indication contraire, aucune partie de cette publication ne peut être reproduite ni utilisée sous quelque forme que ce soit et par aucun procédé, électronique ou mécanique, y compris la photocopie et les microfilms, sans l'accord écrit de l'IEC ou du Comité national de l'IEC du pays du demandeur. Si vous avez des questions sur le copyright de l'IEC ou si vous désirez obtenir des droits supplémentaires sur cette publication, utilisez les coordonnées ci-après ou contactez le Comité national de l'IEC de votre pays de résidence.

IEC Secretariat
3, rue de Varembe
CH-1211 Geneva 20
Switzerland

Tel.: +41 22 919 02 11
info@iec.ch
www.iec.ch

About the IEC

The International Electrotechnical Commission (IEC) is the leading global organization that prepares and publishes International Standards for all electrical, electronic and related technologies.

About IEC publications

The technical content of IEC publications is kept under constant review by the IEC. Please make sure that you have the latest edition, a corrigendum or an amendment might have been published.

IEC publications search - webstore.iec.ch/advsearchform

The advanced search enables to find IEC publications by a variety of criteria (reference number, text, technical committee, ...). It also gives information on projects, replaced and withdrawn publications.

IEC Just Published - webstore.iec.ch/justpublished

Stay up to date on all new IEC publications. Just Published details all new publications released. Available online and once a month by email.

IEC Customer Service Centre - webstore.iec.ch/csc

If you wish to give us your feedback on this publication or need further assistance, please contact the Customer Service Centre: sales@iec.ch.

IEC Products & Services Portal - products.iec.ch

Discover our powerful search engine and read freely all the publications previews, graphical symbols and the glossary. With a subscription you will always have access to up to date content tailored to your needs.

Electropedia - www.electropedia.org

The world's leading online dictionary on electrotechnology, containing more than 22 500 terminological entries in English and French, with equivalent terms in 25 additional languages. Also known as the International Electrotechnical Vocabulary (IEV) online.

A propos de l'IEC

La Commission Electrotechnique Internationale (IEC) est la première organisation mondiale qui élabore et publie des Normes internationales pour tout ce qui a trait à l'électricité, à l'électronique et aux technologies apparentées.

A propos des publications IEC

Le contenu technique des publications IEC est constamment revu. Veuillez vous assurer que vous possédez l'édition la plus récente, un corrigendum ou amendement peut avoir été publié.

Recherche de publications IEC -

webstore.iec.ch/advsearchform

La recherche avancée permet de trouver des publications IEC en utilisant différents critères (numéro de référence, texte, comité d'études, ...). Elle donne aussi des informations sur les projets et les publications remplacées ou retirées.

IEC Just Published - webstore.iec.ch/justpublished

Restez informé sur les nouvelles publications IEC. Just Published détaille les nouvelles publications parues. Disponible en ligne et une fois par mois par email.

Service Clients - webstore.iec.ch/csc

Si vous désirez nous donner des commentaires sur cette publication ou si vous avez des questions contactez-nous: sales@iec.ch.

IEC Products & Services Portal - products.iec.ch

Découvrez notre puissant moteur de recherche et consultez gratuitement tous les aperçus des publications, symboles graphiques et le glossaire. Avec un abonnement, vous aurez toujours accès à un contenu à jour adapté à vos besoins.

Electropedia - www.electropedia.org

Le premier dictionnaire d'électrotechnologie en ligne au monde, avec plus de 22 500 articles terminologiques en anglais et en français, ainsi que les termes équivalents dans 25 langues additionnelles. Egalement appelé Vocabulaire Electrotechnique International (IEV) en ligne.

INTERNATIONAL STANDARD

NORME INTERNATIONALE



Digital video interface – Gigabit video interface for multimedia systems

Interface vidéo numérique – Interface vidéo gigabit pour les systèmes multimédias

Document Preview

[IEC 62889:2024](https://standards.iteh.ai/catalog/standards/iec/901e3018-e094-407b-af8b-411dc1d6cca1/iec-62889-2024)

<https://standards.iteh.ai/catalog/standards/iec/901e3018-e094-407b-af8b-411dc1d6cca1/iec-62889-2024>

INTERNATIONAL
ELECTROTECHNICAL
COMMISSION

COMMISSION
ELECTROTECHNIQUE
INTERNATIONALE

ICS 33.160.40, 33.160.60, 35.200

ISBN 978-2-8322-8120-8

**Warning! Make sure that you obtained this publication from an authorized distributor.
Attention! Veuillez vous assurer que vous avez obtenu cette publication via un distributeur agréé.**

CONTENTS

FOREWORD.....	5
INTRODUCTION.....	7
1 Scope.....	8
2 Normative references	8
3 Terms, definitions and abbreviated terms	8
3.1 Terms and definitions.....	8
3.2 Abbreviated terms.....	11
4 Architecture.....	11
5 Electrical characteristics.....	12
5.1 General.....	12
5.2 AC electrical specifications	12
6 Front-end.....	14
6.1.1 General	14
6.1.2 TX Front-end	15
6.1.3 RX Front-end.....	15
6.1.4 Configuration block diagram	15
6.1.5 Data mapping	15
7 Transition state link	17
8 Protocol.....	18
8.1 Downstream encoder.....	18
8.1.1 General	18
8.1.2 GHDS and GLDS concatenation	18
8.1.3 Scrambler.....	18
8.1.4 5B/6B conversion	19
8.2 Downstream decoder.....	19
8.3 Upstream encoder	20
8.3.1 GLUS concatenation.....	20
8.3.2 Scrambler.....	20
8.3.3 5B/6B conversion	20
8.3.4 Upstream decoder	20
9 Transmission system and transmission line of electrical characteristics.....	21
Annex A (informative) GVIF2 multiple contents transmission.....	22
Annex B (normative) GVIF standard specification	24
B.1 Architecture	24
B.2 Electrical characteristics	25
B.2.1 DC electrical specifications.....	25
B.2.2 AC electrical specifications	26
B.3 Front-end.....	27
B.3.1 General	27
B.3.2 TX front-end	27
B.3.3 RX front-end.....	28
B.4 Transition state link.....	28
B.5 Protocol	29
B.5.1 General	29
B.5.2 Encoder.....	29
B.5.3 Decoder.....	32

B.6	Transmission system and transmission line of electrical characteristics	32
Annex C (informative)	GVIF Multiple link application	34
C.1	Single-link application example	34
C.1.1	Block diagram for single-link transmission	34
C.1.2	Data mapping of single-link transmission	35
C.2	Multiple-link application example.....	35
C.2.1	Block diagram for 2-pair parallel transmission.....	35
C.2.2	Data mapping of 2-pair transmission.....	36
	Bibliography.....	37
	Figure 1 – Architecture of the GVIF2.....	12
	Figure 2 – Level definition of GVIF2.....	13
	Figure 3 – GVIF2 downstream eye mask (at TP1)	13
	Figure 4 – GVIF2 upstream eye mask (at TP2)	14
	Figure 5 – Front-end block diagram of GVIF2.....	14
	Figure 6 – GVIF2 configuration block diagram Data mapping	15
	Figure 7 – GVIF2 RGB888 data mapping	16
	Figure 8 – GVIF2 mapping for general content data(optional)	16
	Figure 9 – Transaction state diagram of GVIF2	17
	Figure 10 – REF and WSYNC signals of GVIF2 downstream.....	18
	Figure 11 – WSYNC signal of upstream	18
	Figure 12 – Downstream encoding	19
	Figure 13 – Downstream decoding	20
	Figure 14 – GLUS word structure	20
	Figure 15 – Test points of GVIF2	21
	Figure 16 – S21 template for GVIF2 transmission line.....	21
	Figure A.1 – GVIF2 transmission for single content.....	22
	Figure A.2 – GVIF2 multiplex transmission for multiple contents	23
	Figure B.1 – Architecture of the GVIF	24
	Figure B.2 – VOD and VOS diagrams	25
	Figure B.3 – Transmitter eye mask specifications (TP1).....	26
	Figure B.4 – Front-end block diagram	27
	Figure B.5 – Transition state link	29
	Figure B.6 – Encoder output diagram.....	30
	Figure B.7 – C-format word.....	31
	Figure B.8 – H-format word.....	32
	Figure B.9 – Transmission system	33
	Figure B.10 – Transmission line tolerance impedance.....	33
	Figure B.11 – Transmission loss	33
	Figure C.1 – Differential single-link block diagram	34
	Figure C.2 – Pixel configuration	35
	Figure C.3 – Multiple-link application block diagram.....	35
	Figure C.4 – Pixel configuration when using 2-pairs.....	36

Table 1 – AC electrical specification of GVIF2	13
Table 2 – 5B/6B conversion	19
Table A.1 – GVIF2 data rate of transmission and number of the DATA SLOT.....	22
Table B.1 – DC electrical specifications of the transmitter.....	25
Table B.2 – DC electrical specifications of the receiver.....	26
Table B.3 – AC electrical specifications of the transmitter.....	26
Table B.4 – AC electrical specifications of the receiver	27
Table B.5 – 4B/5B conversion.....	31
Table B.6 – VSYNC, HSYNC, DE, CNTL/AUX, SDA, TDA transition and the corresponding header	32

iTeh Standards
(<https://standards.iteh.ai>)
Document Preview

[IEC 62889:2024](#)

<https://standards.iteh.ai/catalog/standards/iec/901e3018-e094-407b-af8b-411dc1d6cca1/iec-62889-2024>

INTERNATIONAL ELECTROTECHNICAL COMMISSION

**DIGITAL VIDEO INTERFACE –
GIGABIT VIDEO INTERFACE FOR MULTIMEDIA SYSTEMS****FOREWORD**

- 1) The International Electrotechnical Commission (IEC) is a worldwide organization for standardization comprising all national electrotechnical committees (IEC National Committees). The object of IEC is to promote international co-operation on all questions concerning standardization in the electrical and electronic fields. To this end and in addition to other activities, IEC publishes International Standards, Technical Specifications, Technical Reports, Publicly Available Specifications (PAS) and Guides (hereafter referred to as "IEC Publication(s)"). Their preparation is entrusted to technical committees; any IEC National Committee interested in the subject dealt with may participate in this preparatory work. International, governmental and non-governmental organizations liaising with the IEC also participate in this preparation. IEC collaborates closely with the International Organization for Standardization (ISO) in accordance with conditions determined by agreement between the two organizations.
- 2) The formal decisions or agreements of IEC on technical matters express, as nearly as possible, an international consensus of opinion on the relevant subjects since each technical committee has representation from all interested IEC National Committees.
- 3) IEC Publications have the form of recommendations for international use and are accepted by IEC National Committees in that sense. While all reasonable efforts are made to ensure that the technical content of IEC Publications is accurate, IEC cannot be held responsible for the way in which they are used or for any misinterpretation by any end user.
- 4) In order to promote international uniformity, IEC National Committees undertake to apply IEC Publications transparently to the maximum extent possible in their national and regional publications. Any divergence between any IEC Publication and the corresponding national or regional publication shall be clearly indicated in the latter.
- 5) IEC itself does not provide any attestation of conformity. Independent certification bodies provide conformity assessment services and, in some areas, access to IEC marks of conformity. IEC is not responsible for any services carried out by independent certification bodies.
- 6) All users should ensure that they have the latest edition of this publication.
- 7) No liability shall attach to IEC or its directors, employees, servants or agents including individual experts and members of its technical committees and IEC National Committees for any personal injury, property damage or other damage of any nature whatsoever, whether direct or indirect, or for costs (including legal fees) and expenses arising out of the publication, use of, or reliance upon, this IEC Publication or any other IEC Publications.
- 8) Attention is drawn to the Normative references cited in this publication. Use of the referenced publications is indispensable for the correct application of this publication.
- 9) IEC draws attention to the possibility that the implementation of this document may involve the use of (a) patent(s). IEC takes no position concerning the evidence, validity or applicability of any claimed patent rights in respect thereof. As of the date of publication of this document, IEC had received notice of (a) patent(s), which may be required to implement this document. However, implementers are cautioned that this may not represent the latest information, which may be obtained from the patent database available at <https://patents.iec.ch>. IEC shall not be held responsible for identifying any or all such patent rights.

IEC 62889 has been prepared by Technical Area 4: Digital system interfaces and protocols, of IEC Technical Committee 100: Audio, video and multimedia systems and equipment. It is an International Standard.

JEITA CP-6101B served as a basis for the elaboration of this document.

This second edition cancels and replaces the first edition published in 2015. This edition constitutes a technical revision.

This edition includes the following significant technical changes with respect to the previous edition:

- a) Addition of a new technology interface, GVIF2.

The text of this International Standard is based on the following documents:

Draft	Report on voting
100/3912/CDV	100/4040/RVC

Full information on the voting for its approval can be found in the report on voting indicated in the above table.

The language used for the development of this International Standard is English.

This document was drafted in accordance with ISO/IEC Directives, Part 2, and developed in accordance with ISO/IEC Directives, Part 1 and ISO/IEC Directives, IEC Supplement, available at www.iec.ch/members_experts/refdocs. The main document types developed by IEC are described in greater detail at www.iec.ch/publications.

The committee has decided that the contents of this document will remain unchanged until the stability date indicated on the IEC website under webstore.iec.ch in the data related to the specific document. At this date, the document will be

- reconfirmed,
- withdrawn, or
- revised.

iTeh Standards

IMPORTANT – The "colour inside" logo on the cover page of this document indicates that it contains colours which are considered to be useful for the correct understanding of its contents. Users should therefore print this document using a colour printer.

[IEC 62889:2024](https://standards.iteh.ai/catalog/standards/iec/901e3018-e094-407b-af8b-411dc1d6cca1/iec-62889-2024)

<https://standards.iteh.ai/catalog/standards/iec/901e3018-e094-407b-af8b-411dc1d6cca1/iec-62889-2024>

INTRODUCTION

This International Standard is based on JEITA CP-6101B: *Digital monitor interface GVIF*, which was originally specified by the Japan Electronics and Information Technology Industries Association (JEITA).

The Gigabit Video InterFace (GVIF) is a serial point-to-point interface supporting uncompressed digital video links that was designed to address the needs of automotive navigation and entertainment systems, etc., to transport baseband digital video information. GVIF applies low-voltage differential signalling (LVDS) technology and makes use of a thin cable consisting of a single shielded twisted pair of conductors that exhibits high noise immunity and low EMI, and is optimized for small size and low weight. GVIF supports display resolutions ranging from WQVGA through WUXGA with a maximum of 24 bits per pixel colour video data, and can transmit a baseband video signal over cable lengths over 10 m. Optionally, GVIF supports audio data transmission and user data transmission.

Gigabit Video InterFace 2 (GVIF2) is a baseband transmission method for digital video information that applies serial data transmission technology. In the downstream transmission from GVIF2 TX to GVIF2 RX, the high-bandwidth data for video information (GHDS) and the device control signal (GLDS) are transmitted by using the time-division multiplexing method. In the upstream transmission from GVIF2 RX to GVIF2 TX, the control signal GLUS is transmitted. The upstream transmission and downstream transmission occur in full duplex. Optionally, GVIF2 also supports audio data transmission and user data transmission.

Also optionally, when paired with high-bandwidth digital content protection (HDCP), the GVIF's standard functions and features address all of the requirements for delivering content-protected video from a source to a video display monitor.

This document describes the GVIF family that consists of GVIF2 in the main body and Annex A, and GVIF in Annex B and Annex C.

GVIF2 has the following features: [IEC 62889:2024](https://standards.iteh.ai/catalog/standards/iec/901e3018-e094-407b-af8b-411dc1d6cca1/iec-62889-2024)

- transmission by a differential shielded twisted-pair cable or coaxial cable,
- to enable multiple video and audio content transmission using time-division multiplexing,
- possibility to use audio transmission, bi-direction user communication, and HDCP (high-bandwidth digital content protection) technology (optional),
- availability for daisy chain transmission (optional).

The Association of Radio Industries and Businesses (ARIB) refers to GVIF and GVIF2 in its standard ARIB STD-B21 as being authorized digital video output interfaces.

DIGITAL VIDEO INTERFACE – GIGABIT VIDEO INTERFACE FOR MULTIMEDIA SYSTEMS

1 Scope

This document describes two serial digital interfaces, Gigabit Video InterFace (GVIF) and Gigabit Video InterFace2 (GVIF2), for the interconnection of digital video equipment. GVIF and GVIF2 are primarily intended to carry high-speed digital video data for general usage and are well suited for multimedia entertainment systems in a vehicle.

This document specifies the physical layer of the interface, including transmission line characteristics and electrical characteristics of transmitters and receivers. Mechanical and physical specifications of connectors are not included.

2 Normative references

The following documents are referred to in the text in such a way that some or all of their content constitutes requirements of this document. For dated references, only the edition cited applies. For undated references, the latest edition of the referenced document (including any amendments) applies.

ITU-R BT.601-5, *Studio encoding parameters of digital television for standard 4:3 and wide-screen 16:9 aspect ratios*

ITU-R BT.656-5, *Interface for digital component video signals in 525-line and 625-line television systems operating at the 4:2:2 level of Recommendation ITU-R BT.601*

3 Terms, definitions and abbreviated terms

3.1 Terms and definitions

For the purposes of this document, the following terms and definitions apply.

ISO and IEC maintain terminology databases for use in standardization at the following addresses:

- IEC Electropedia: available at <https://www.electropedia.org/>
- ISO Online browsing platform: available at <https://www.iso.org/obp>

3.1.1

DE

display enable signal given in IEC 62315-1

3.1.2

HSYNC

display horizontal synchronous signal given in IEC 62315-1

3.1.3

VSYNC

display vertical synchronous signal given in IEC 62315-1

3.1.4**RGB**

display red, green, blue colour data input (TX) or output (RX) given in ITU-R BT.601-5 and ITU-R BT.656-5

3.1.5**CNTL/AUX**

downstream user-defined signal or audio enable signal

3.1.6**P[23:0]**

digital signal data such as 24-bit colour video data, for example RGB data input (TX) or output (RX)

3.1.7**GHDS**

GVIF2 High bandwidth DownStream

high-bandwidth downstream content data of the GVIF2 format

3.1.8**GLDS**

GVIF2 Low bandwidth DownStream

low-bandwidth downstream control signal data of the GVIF2 format

3.1.9**GLUS**

GVIF2 Low bandwidth UpStream

low-bandwidth upstream control signal data of the GVIF2 format

3.1.10**GVIF RX**

circuit that receives the serial signal from a shielded-pair transmission line, decodes it and converts it into a parallel video signal

3.1.11**GVIF TX**

circuit that receives the parallel video signal and the control signals, and encodes them into serial data to send a signal by driving a shielded-pair transmission line

3.1.12**GVIF2 RX**

circuit that receives the serial signal from a shielded twisted-pair cable or coaxial cable, decodes it and converts it into video and audio/control signals

3.1.13**GVIF2 TX**

circuit that receives the video and audio/control signals, encodes them into serial data and sends a signal by driving a shielded twisted-pair cable or coaxial cable

3.1.14**LOS**

loss of signal detection, asserted when the differential input signal at the receiver cannot be received

3.1.15**RX front-end**

front-end block of receiver side

3.1.16

SDA

serial data down-stream signal

3.1.17

SDATA

GVIF2 serial data signal on coaxial cable transmission

3.1.18

SDATAP

down-stream positive-phase side signal of the differential serial data

3.1.19

SDATAN

down-stream negative-phase side signal of the differential serial data

3.1.20

REF

reference signal

3.1.21

REFRQP

current source positive signal for reference clock request from RX side

3.1.22

REFRQN

current source negative signal for reference clock request from RX side

3.1.23

SFTCLK

pixel clock for capture of the parallel video data per pixel

3.1.24

TDA

transmit data down-stream user-defined signal

3.1.25

TX front-end

front-end block of transmitter side

3.1.26

UDA

up-stream user defined ancillary data signal

3.1.27

IRQ

up-stream common-mode reference request current for REFRQP/N

3.1.28

VOS

common-mode voltage amplitude of reference request

3.1.29

VOD

differential voltage amplitude for SDATAP/N

3.1.30**VDD**

power supply on the transmitter side

3.1.31**V_SDATAP**

single-ended voltage of SDATAP

3.1.32**V_SDATAN**

single-ended voltage of SDATAN

3.1.33**TP1**

test point of a downstream eye mask specification

3.1.34**TP2**

test point of an upstream eye mask specification

3.1.35**normalized differential voltage**

voltage of transmitter output point

3.1.36**UI**

normalized time unit interval of transmitter output point

3.1.37**WSYNC**

word synchronized signal

3.2 Abbreviated terms

AC	alternating current
DC	direct current
EMI	electro-magnetic interference
GVIF	Gigabit Video InterFace
HDCP	high-bandwidth digital content protection
LSB	least significant bit
LVDS	low voltage differential signalling
MSB	most significant bit
PRBS	pseudo random binary sequence

4 Architecture

The GVIF2 has a higher capability multimedia interface and is considered as the next generation of GVIF, which is described in Annex B and Annex C.

The GVIF2 transmission line is a shielded twisted-pair cable with the differential characteristic impedance Z_{0_diff} or a coaxial cable with the characteristic impedance Z_{0_coax} , and is connected to GVIF2 RX and GVIF2 TX, with an AC coupling capacitor, and high-frequency terminated resistor (see Figure 1). The signal path of the transmission line of GVIF2 is DC isolated from both GVIF2 TX and GVIF2 RX. The shield of the transmission line of GVIF2 is connected to the GND of the TX circuit and of the RX circuit.

In the case of coaxial transmission line

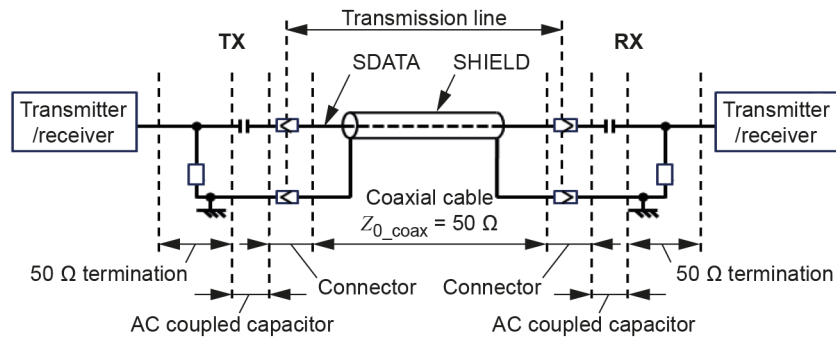

In the case of shielded twisted-pair transmission line

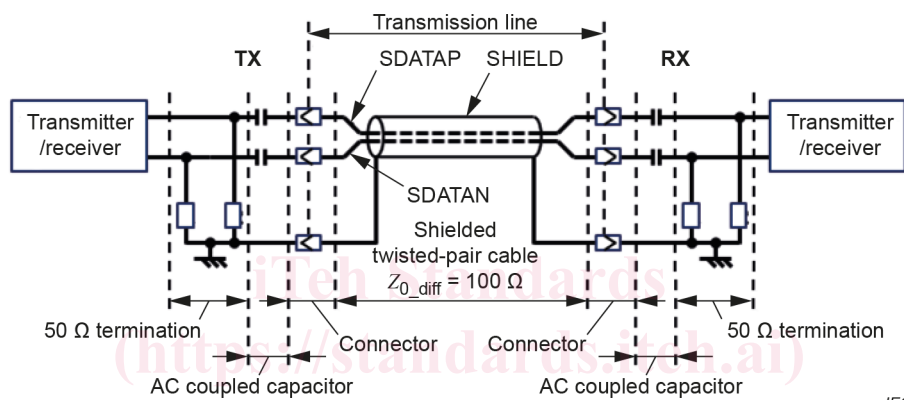

IEC

Reproduced, with modifications, from JEITA CP-6101B, Figure 3-4, with permission from JEITA.

Figure 1 – Architecture of the GVIF2

<https://standards.iteh.ai/catalog/standards/iec/901e3018-e094-407b-af8b-411dc1d6cca1/iec-62889-2024>

5 Electrical characteristics

5.1 General

AC specifications described in below shall be satisfied. GVIF2 does not specify DC specifications because the transmission architecture of GVIF2 is a complete AC coupling.

5.2 AC electrical specifications

The AC electrical specifications of the transmitter and receiver side are given in Table 1. The definition of voltage levels are shown in Figure 2, and Figure 3 and Figure 4 show a downstream eye mask specification at TP1 and an upstream eye mask specification at TP2 for GVIF2.