



Designation: E582 – 21

Standard Test Method for Minimum Ignition Energy and Quenching Distance in Gaseous Mixtures¹

This standard is issued under the fixed designation E582; the number immediately following the designation indicates the year of original adoption or, in the case of revision, the year of last revision. A number in parentheses indicates the year of last reappraisal. A superscript epsilon (ϵ) indicates an editorial change since the last revision or reappraisal.

1. Scope

1.1 This test method covers the determination of minimum energy for ignition (initiation of deflagration) and associated flat-plate ignition quenching distances.² The complete description is specific to alkane or alkene fuels admixed with air at normal ambient temperature and pressure. This method is applicable to mixtures of the specified fuels with air, varying from the most easily ignitable mixture to mixtures near to, in theory, the limit-of-flammability compositions.

NOTE 1—The test apparatus described in Section 4 is not suitable for near limit mixtures. Near limit mixtures require a much larger test volume (that is, reaction vessel), and the capability for producing much larger spark energies.

1.2 Extensions to other fuel-oxidizer combinations, and to other temperatures and pressures can be accomplished with all the accuracy inherent in this method if certain additional conditions are met: (a) mixture stability and compatibility with bomb, seal, and other materials is established through time tests described in Section 9; (b) the expected peak pressure from the test is within the pressure rating of the bomb (established as required by the particular research laboratory); (c) spark breakdown within the bomb is consistent with Paschen's law for the distance being tested; (d) the temperature, including that of the discharge electrodes, is uniform; and (e) if the temperature is other than ambient, the energy storage capacitance required is less than about 9 pF.

1.3 This method is one of several being developed by Committee E27 for determining the hazards of chemicals, including their vapors in air or other oxidant atmospheres. The measurements are useful in assessing fuel ignitability hazards due to static or other electrical sparks. However, the quenching distance data must be used with great prudence since they are primarily applicable to the ignition stage and therefore, repre-

¹ This test method is under the jurisdiction of ASTM Committee E27 on Hazard Potential of Chemicals and is the direct responsibility of Subcommittee E27.04 on Flammability and Ignitability of Chemicals.

Current edition approved June 1, 2021. Published July 2021. Originally approved in 1976. Last previous edition approved in 2013 as E582 – 07 (2013)¹. DOI: 10.1520/E0582-21.

² Litchfield, E. L., Hay, M. H., Kubala, T. S., and Monroe, J. S., "Minimum Ignition Energy and Quenching Distance in Gaseous Mixtures," *BuMines*, R. L. 7009, August 1967, p. 11.

sent values for initial pressure and not the smaller values existing at higher pressures.

1.4 The values stated in inch-pound units are to be regarded as standard. The values given in parentheses are mathematical conversions to SI units that are provided for information only and are not considered standard.

1.5 *This standard should be used to measure and describe the properties of materials, products, or assemblies in response to heat and flame under controlled laboratory conditions and should not be used to describe or appraise the fire hazard or fire risk of materials, products, or assemblies under actual fire conditions. However, results of this test may be used as elements of a fire risk assessment which takes into account all of the factors which are pertinent to an assessment of the fire hazard of a particular end use.*

1.6 *This standard does not purport to address all of the safety concerns, if any, associated with its use. It is the responsibility of the user of this standard to establish appropriate safety, health, and environmental practices and determine the applicability of regulatory limitations prior to use. Specific safety precautions are listed in Section 5.*

1.7 *This international standard was developed in accordance with internationally recognized principles on standardization established in the Decision on Principles for the Development of International Standards, Guides and Recommendations issued by the World Trade Organization Technical Barriers to Trade (TBT) Committee.*

2. Terminology

2.1 Definitions:

2.1.1 *ignition, n*—the initiation of combustion.

2.1.2 *minimum ignition energy (MIE), n*—electrical energy discharged from a capacitor, which is just sufficient to effect ignition of the most easily ignitable concentration of fuel in air under the specific test conditions.

2.2 Definitions of Terms Specific to This Standard:

2.2.1 *ignition quenching distance, n*—maximum spacing between electrode flanges that will not permit spark ignition and flame propagation beyond the flanges, when tested under the specified test conditions.

3. Significance and Use

3.1 The minimum energies provide a basis for comparing the ease of ignition of gases. The flatplate ignition quenching distances provide an important verification of existing minimum ignition energy data and give approximate values of the propagation quenching distances of the various mixtures. It is emphasized that maximum safe experimental gaps, as from “flame-proof” or “explosion-proof” studies, are less than the flat-plate ignition quenching distances.

4. Apparatus

4.1 *Reaction Vessel*—The recommended reaction vessel is manufactured according to the specifications of Fig. 1 and Fig. 2. This is a spherical vessel, manufactured of Type 304 stainless steel, and passivated after machining. The spherical geometry maximizes the useable spark-gap length for a given vessel volume. The reaction vessel provides for opposed mounting of the spark electrodes which permits rapid and convenient variation of the gap length without the necessity for

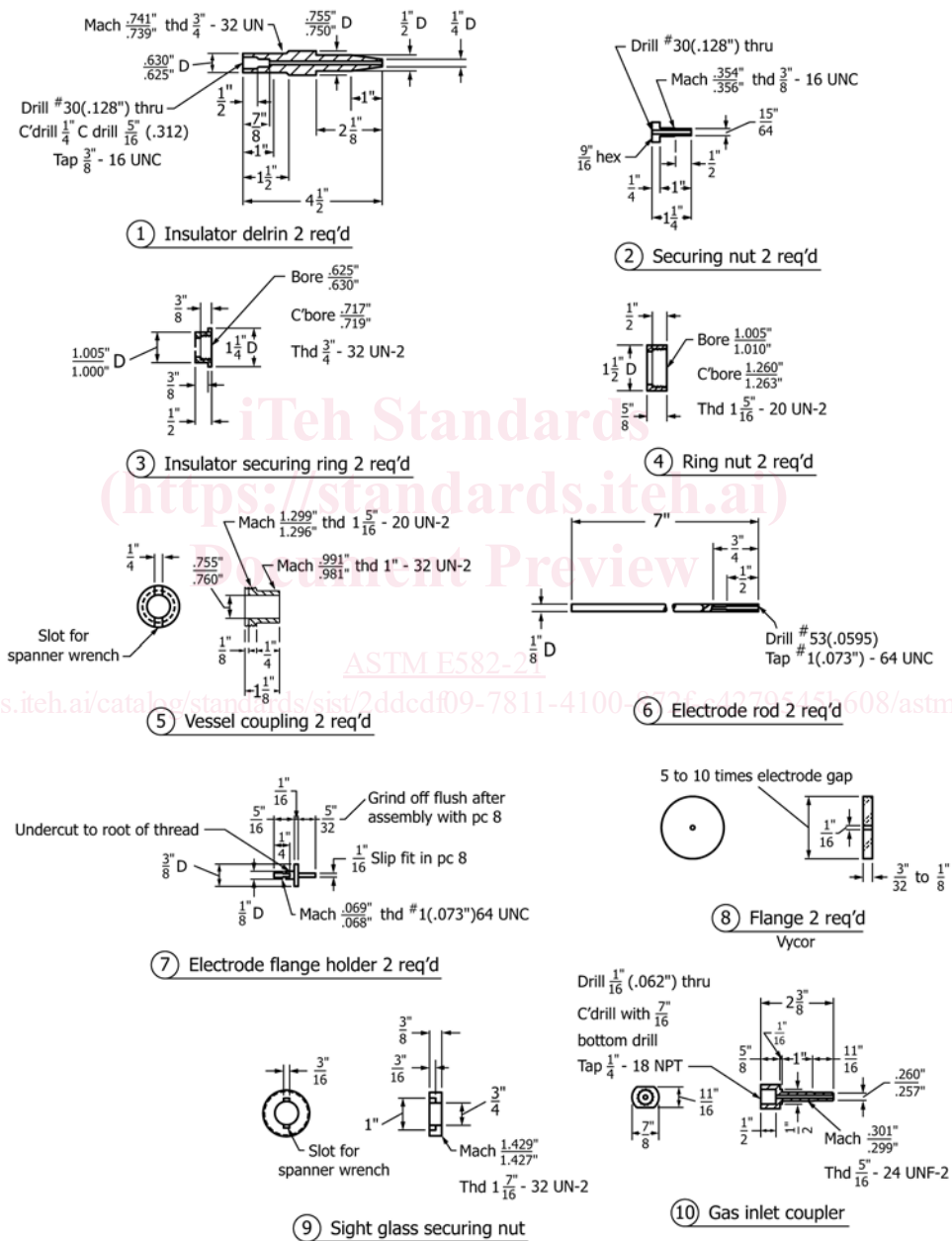

- NOTE 1—Tolerance is ± 0.010 in., unless noted.
- NOTE 2—Break all sharp edges.
- NOTE 3—Material is Type 304 stainless steel.
- NOTE 4—Thread depth is 75 to 80 %.
- NOTE 5—1 in. = 25.4 mm.

FIG. 1 Electrode Assembly (I)

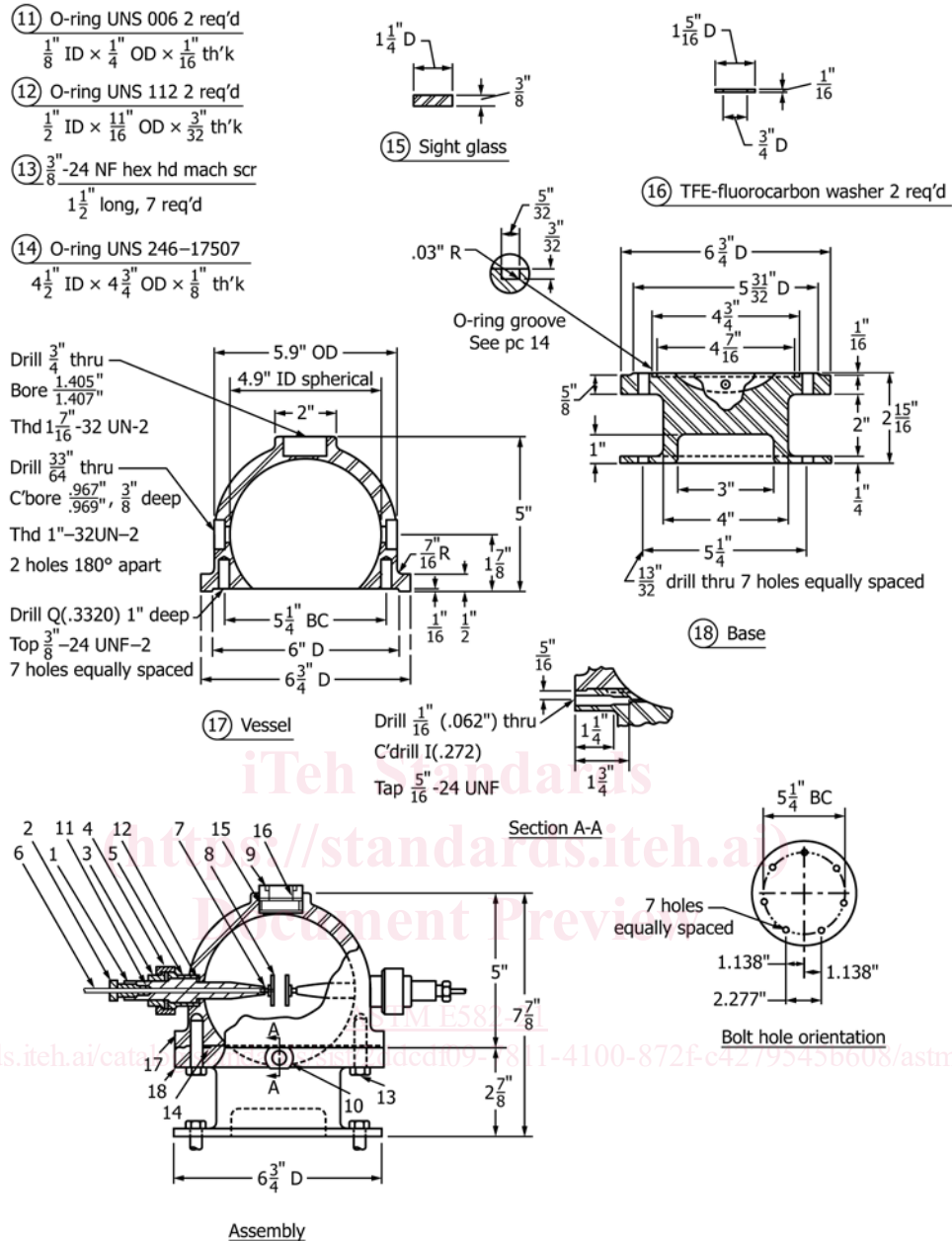

- NOTE 1—Tolerance is ± 0.010 in., unless noted.
 NOTE 2—Break all sharp edges.
 NOTE 3—Material is Type 304 stainless steel.
 NOTE 4—Thread depth is 75 to 80 %.
 NOTE 5—1 in. = 25.4 mm.

FIG. 2 Electrode Assembly (II)

opening the vessel. The input orifice (Fig. 2, Section A-A) is located so that the gases are introduced approximately tangentially to the vessel walls, thus providing a turbulent swirling motion that facilitates mixing. A sight glass permits direct observation of flame initiation and propagation throughout the reaction volume.

4.2 Electrode Assembly:

4.2.1 The electrodes (Fig. 1) have metal tips flanged with glass plates. The tips screw into $\frac{1}{8}$ -in. stainless steel rods which extend through inserts in the bomb walls to permit

external electrical connections. Gas seals are provided between the reaction vessel and the inserts and between the inserts and the $\frac{1}{8}$ -in. rods by O-ring seals (see Fig. 2, Assembly). The glass flange material should be either borosilicate or high silica and the flanges should be fastened to the stainless-steel tips with a thin layer of epoxy cement. The facing surfaces should be planar and coplanar to 0.001 in. (0.025 mm) or 1 % of the intended test gap, whichever is larger.

NOTE 2—Customarily, electrode flanges are not mounted when this standard is used to determine the minimum ignition energy alone. Flanges

are essential only for flat-plate ignition quenching distance determination.

4.2.2 Two inserts are required to carry the 1/8-in. rods through the walls of the reaction vessel. At least one of these inserts must be made of high-electrical resistivity insulating material. Hard rubber, phenolic plastic, poly(methyl methacrylate) (PMMA), and many other materials are suitable for use with the alkane and alkene fuels. In the excepted cases (other similarly energetic fuels), the insulating material must not react with or absorb the fuel being tested.

4.2.3 Where the test arrangement is optimized through the use of a “double-ended” power supply (see Fig. 3(b)), two insulating inserts are required. Otherwise, one of the inserts may be machined from Type 304 stainless steel.

4.2.4 Insulation between the two electrodes should exceed $10^{12} \Omega$ as discussed in 4.3.3.

4.2.5 Measurement of the gap width is made by available techniques and implements most suitable for the gap distance being measured. Calibrated leaf gauges, inside micrometres, or vernier calipers are suitable, depending upon the gap distance. The measurements should be made with a repeatability of ± 0.001 in. (0.025 mm) or 1 %, whichever is most conservative. To facilitate such measurements, it is helpful to have leaf gauges of known thicknesses for frequently used gap distances. High-quality machinist’s micrometres will generally provide adequate accuracy.

4.3 Power Supply and Electrical Circuit:

4.3.1 The power supply should be of the oscillator type, so that its filter condensers will be electrically small. The maximum output current should be about 1 mA. (Warning—With

such a power supply, the probability of lethal shock to the operator from the high-voltage circuits becomes negligible. However, all usual and normal hazards to personnel will exist on the 60-Hz supply, main-side of the power supply.)

4.3.2 The power supply can be single-sided with one high-voltage output terminal and one low-voltage, neutral, or ground terminal (see Fig. 3(a)). Alternatively, the power supply may be double-ended with two high-voltage output terminals, one negative and one positive, together with a center-tapped grounding or neutral connection (see Fig. 3(b)). For maximum testing flexibility, the power supply should deliver variable or adjustable output voltage differences between 1 and 30 kV.

NOTE 3—The double-ended power supply should be used only in conjunction with two insulating inserts. The metal bomb structure must then be connected to the power supply center point and connected to system ground. The double-ended power supply gives somewhat higher gap breakdown voltages at larger spark gaps and, thus, somewhat lower ignition energies. This consideration should be of importance only if the very highest quality data are required.

4.3.3 The output filter capacitors of the power supply must be isolated from the discharge energy storage capacitance by an isolating resistor. The resistive-capacitive time constant of the charging circuit containing the energy storage capacitance should be several seconds; $10^{12} \Omega$ is a desirable value for the most easily ignitable mixture (energy storage capacitance of 8 to 12 pF) with the value reduced inversely as the energy storage capacitance is increased for less easily ignitable mixtures. Two resistors should be used in series, four with the double-ended supply. One resistor shall be immediately at the power supply terminal, the other at the bomb energy storage

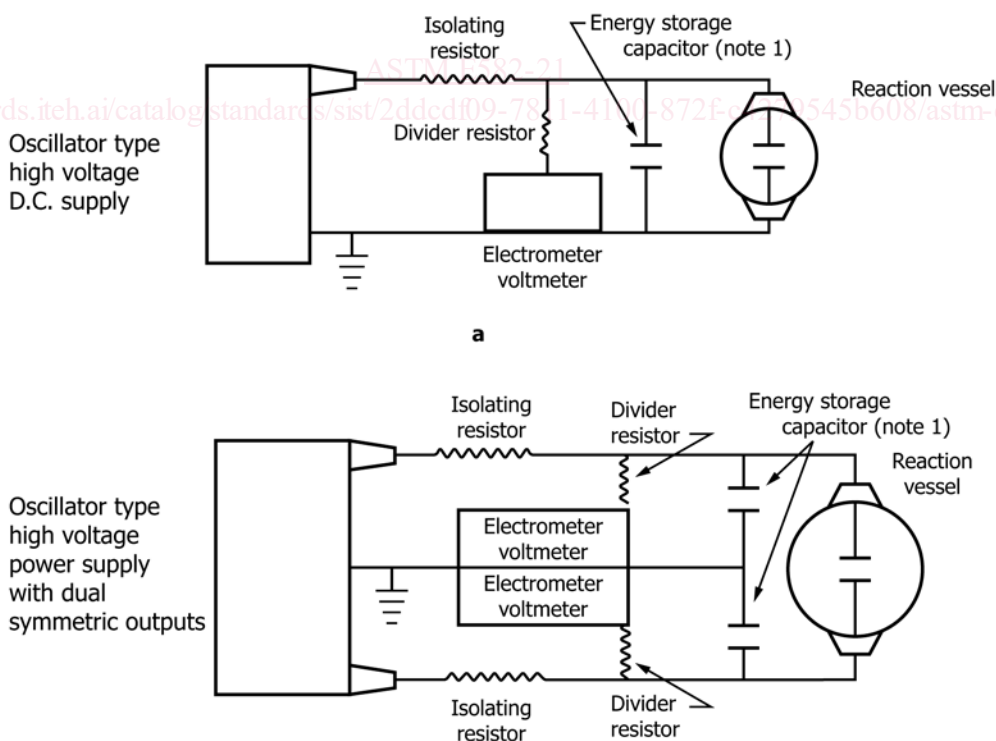

NOTE 1—Distributed capacitance must be considered as part of the energy storage capacitance.

NOTE 2—See 4.3 for component value guidelines.

FIG. 3 Connections of Single and Double-Sided Power Supply in Circuit