



Designation: ~~D8291~~—20a D8291 – 21

## Standard Test Method for Evaluation of Performance of Automotive Engine Oils in the Mitigation of Low-Speed, Preignition in the Sequence IX Gasoline Turbocharged Direct-Injection, Spark-Ignition Engine<sup>1</sup>

This standard is issued under the fixed designation D8291; the number immediately following the designation indicates the year of original adoption or, in the case of revision, the year of last revision. A number in parentheses indicates the year of last reapproval. A superscript epsilon ( $\epsilon$ ) indicates an editorial change since the last revision or reapproval.

### INTRODUCTION

Portions of this test method are written for use by laboratories that make use of ASTM Test Monitoring Center (TMC)<sup>2</sup> services (see [Annex A1](#) – [Annex A4](#)).

The TMC provides reference oils, and engineering and statistical services to laboratories that desire to produce test results that are statistically similar to those produced by laboratories previously calibrated by the TMC.

In general, the test purchaser decides if a calibrated test stand is to be used. Organizations such as the American Chemistry Council require that a laboratory utilize the TMC services as part of their test registration process. In addition, the American Petroleum Institute and the Gear Lubricant Review Committee of the Lubricant Review Institute (SAE International) require that a laboratory use the TMC services in seeking qualification of oils against their specifications.

The advantage of using the TMC services to calibrate test stands is that the test laboratory (and hence the Test Purchaser) has an assurance that the test stand was operating at the proper level of test severity. It should also be borne in mind that results obtained in a non-calibrated test stand may not be the same as those obtained in a test stand participating in the ASTM TMC services process.

Laboratories that choose not to use the TMC services may simply disregard these portions.

ASTM International policy is to encourage the development of test procedures based on generic equipment. It is recognized that there are occasions where critical/sole-source equipment has been approved by the technical committee (surveillance panel/task force) and is required by the test procedure. The technical committee that oversees the test procedure is encouraged to clearly identify if the part is considered critical in the test procedure. If a part is deemed to be critical, ASTM encourages alternate suppliers to be given the opportunity for consideration of supplying the critical part/component providing they meet the approval process set forth by the technical committee.

An alternate supplier can start the process by initiating contact with the technical committee (current chairs shown on ASTM TMC website). The supplier should advise on the details of the part that is intended to be supplied. The technical committee will review the request and determine feasibility of an alternate supplier for the requested replacement critical part. In the event that a replacement critical part has been identified and proven equivalent the sole-source supplier footnote shall be removed from the test procedure.

<sup>1</sup> This test method is under the jurisdiction of ASTM Committee D02 on Petroleum Products, Liquid Fuels, and Lubricants and is the direct responsibility of Subcommittee D02.B0 on Automotive Lubricants.

Current edition approved July 1, 2020/July 1, 2021. Published July 2020/July 2021. Originally approved in 1919. Last previous edition approved in 2020 as ~~D8291 – 20~~ D8291 – 20a. DOI: 10.1520/D8291-20A-10.1520/D8291-21.

<sup>2</sup> Until the next revision of this test method, the ASTM Test Monitoring Center will update changes in the test method by means of information letters. Information letters may be obtained from the ASTM Test Monitoring Center, 6555 Penn Ave., Pittsburgh, PA 15206-4489. Attention: Administrator. This edition incorporates revisions in all information Letters through No. ~~20-1~~ 21-1.

## 1. Scope\*

1.1 This laboratory engine test evaluates the ability of an automotive engine to mitigate preignition in the combustion chambers in gasoline, turbocharged, direct-injection (GTDI) engines under low-speed and high-load operating conditions. This test method is commonly known as the Ford low-speed, preignition (LSPI) test.

1.1.1 In vehicles, equipped with relatively small GTDI spark-ignition engines, preignition has occasionally occurred when the vehicles are operated under low-speed and high-load conditions. Uncontrolled, preignition may cause destructive engine damage.

1.2 The values stated in SI units are to be regarded as standard. No other units of measurement are included in this standard.

1.2.1 *Exceptions*—Where there is no direct SI equivalent such as screw threads, national pipe threads/diameters, tubing size, wire gauge, or specified single source equipment.

1.3 *This standard does not purport to address all of the safety concerns, if any, associated with its use. It is the responsibility of the user of this standard to establish appropriate safety, health, and environmental practices and determine the applicability of regulatory limitations prior to use.*

1.4 *This international standard was developed in accordance with internationally recognized principles on standardization established in the Decision on Principles for the Development of International Standards, Guides and Recommendations issued by the World Trade Organization Technical Barriers to Trade (TBT) Committee.*

## 2. Referenced Documents

### 2.1 ASTM Standards:<sup>3</sup>

- D86 Test Method for Distillation of Petroleum Products and Liquid Fuels at Atmospheric Pressure
- D130 Test Method for Corrosiveness to Copper from Petroleum Products by Copper Strip Test
- D235 Specification for Mineral Spirits (Petroleum Spirits) (Hydrocarbon Dry Cleaning Solvent) (Withdrawn 2021)<sup>4</sup>
- D323 Test Method for Vapor Pressure of Petroleum Products (Reid Method)
- D381 Test Method for Gum Content in Fuels by Jet Evaporation
- D445 Test Method for Kinematic Viscosity of Transparent and Opaque Liquids (and Calculation of Dynamic Viscosity)
- D525 Test Method for Oxidation Stability of Gasoline (Induction Period Method)
- D1298 Test Method for Density, Relative Density, or API Gravity of Crude Petroleum and Liquid Petroleum Products by Hydrometer Method
- D1319 Test Method for Hydrocarbon Types in Liquid Petroleum Products by Fluorescent Indicator Adsorption
- D2622 Test Method for Sulfur in Petroleum Products by Wavelength Dispersive X-ray Fluorescence Spectrometry
- D2699 Test Method for Research Octane Number of Spark-Ignition Engine Fuel
- D2700 Test Method for Motor Octane Number of Spark-Ignition Engine Fuel
- D2709 Test Method for Water and Sediment in Middle Distillate Fuels by Centrifuge
- D3120 Test Method for Trace Quantities of Sulfur in Light Liquid Petroleum Hydrocarbons by Oxidative Microcoulometry
- D3231 Test Method for Phosphorus in Gasoline
- D3237 Test Method for Lead in Gasoline by Atomic Absorption Spectroscopy
- D3525 Test Method for Gasoline Fuel Dilution in Used Gasoline Engine Oils by Wide-Bore Capillary Gas Chromatography
- D4485 Specification for Performance of Active API Service Category Engine Oils
- D4858 Test Method for Determination of the Tendency of Lubricants to Promote Preignition in Two-Stroke-Cycle Gasoline Engines
- D5185 Test Method for Multielement Determination of Used and Unused Lubricating Oils and Base Oils by Inductively Coupled Plasma Atomic Emission Spectrometry (ICP-AES)
- D5453 Test Method for Determination of Total Sulfur in Light Hydrocarbons, Spark Ignition Engine Fuel, Diesel Engine Fuel, and Engine Oil by Ultraviolet Fluorescence
- D5892 Specification for Type IV Polymer-Modified Asphalt Cement for Use in Pavement Construction (Withdrawn 2005)<sup>4</sup>
- D6593 Test Method for Evaluation of Automotive Engine Oils for Inhibition of Deposit Formation in a Spark-Ignition Internal Combustion Engine Fueled with Gasoline and Operated Under Low-Temperature, Light-Duty Conditions
- D6984 Test Method for Evaluation of Automotive Engine Oils in the Sequence IIIF, Spark-Ignition Engine

<sup>3</sup> For referenced ASTM standards, visit the ASTM website, [www.astm.org](http://www.astm.org), or contact ASTM Customer Service at [service@astm.org](mailto:service@astm.org). For *Annual Book of ASTM Standards* volume information, refer to the standard's Document Summary page on the ASTM website.

<sup>4</sup> The last approved version of this historical standard is referenced on [www.astm.org](http://www.astm.org).

**D8047** Test Method for Evaluation of Engine Oil Aeration Resistance in a Caterpillar C13 Direct-Injected Turbocharged Automotive Diesel Engine

**E29** Practice for Using Significant Digits in Test Data to Determine Conformance with Specifications

2.2 American National Standards Institute Standards:<sup>5</sup>

**ANSI MC96.1** Temperature Measurement-Thermocouples

### 3. Terminology

#### 3.1 Definitions:

3.1.1 *engine oil, n*—a liquid that reduces friction or wear, or both, between the moving parts within an engine; removes heat, particularly from the underside of pistons; and serves as a combustion gas sealant for piston rings.

##### 3.1.1.1 Discussion—

It may contain additives to enhance certain properties. Inhibition of engine rusting, deposit formation, valve train wear, oil oxidation, and foaming are examples. **D5892**

3.1.2 *lambda, n*—the ratio of actual air mass induced, during engine operation, divided by the theoretical air mass requirement at the stoichiometric air-fuel ratio for the given fuel.

##### 3.1.2.1 Discussion—

A lambda value of 1.0 denotes a stoichiometric air-fuel ratio. **D6593**

3.1.3 *lubricant test monitoring system (LTMS), n*—an analytical system in which ASTM calibration test data are used to manage test precision and severity (bias). **D6984**

3.1.4 *PCM, n*—an engine control unit, most commonly called the powertrain control module (PCM), is an electronic device that instantaneously controls a series of actuators on an internal combustion engine to ensure optimal engine performance.

3.1.5 *preignition, n*—in a spark-ignition engine, ignition of the mixture of fuel and air in the combustion chamber before the passage of the spark. **D4858**

3.1.6 *quantity, n*—in the SI, a measurable property of a body or substance where the property has a magnitude expressed as the product of a number and a unit; there are seven, well-defined base quantities (length, time, mass, temperature, amount of substance, electric current and luminous intensity) from which all other quantities are derived (for example, volume whose SI unit is the cubic metre).

##### 3.1.6.1 Discussion—

Symbols for quantities must be carefully defined; are written in italic font, can be upper or lower case, and can be qualified by adding further information in subscripts, or superscripts, or in parentheses (for example,  $t_{\text{fuel}} = 40\text{ }^{\circ}\text{C}$ , where  $t$  is used as the symbol for the quantity Celsius temperature and  $t_{\text{fuel}}$  is the symbol for the specific quantity fuel temperature). **D8047**

#### 3.2 Acronyms and Abbreviations (*italic font denotes the symbol for a quantity*):

3.2.1 *AvPIE*—average preignition events

3.2.2 CAN—controller area network

3.2.3 DAC—digital-to-analog converter

3.2.4 DACA—data acquisition and control automation

3.2.5  $e_r$ —prediction error

3.2.6 ECU—electronic control unit

3.2.7 EEC—electronic engine control

<sup>5</sup> Available from American National Standards Institute (ANSI), 25 W. 43rd St., 4th Floor, New York, NY 10036, <http://www.ansi.org>.

- 3.2.8 *F*—quantile
- 3.2.9 *G*—skewness
- 3.2.10 GTDI—gasoline turbocharged direct injection
- 3.2.11 *IBP*—initial boiling point
- 3.2.12 *ID*—internal diameter
- 3.2.13 *ip*—intermediate precision
- 3.2.14 *K*—kurtosis
- 3.2.15 LCR—lower compression ring
- 3.2.16 LTMS—lubricant test monitoring system
- 3.2.17 LSPI—low-speed preignition
- 3.2.18 *M*—mean
- 3.2.19 MAF—mass air flow
- 3.2.20 *MAP*—manifold absolute pressure
- 3.2.21 *MAPT*—manifold absolute pressure and temperature
- 3.2.22 *MFB*—mass fraction burn
- 3.2.23 *MFB2*—mass fraction burn at 2 %
- 3.2.24 PCM—powertrain control module
- 3.2.25 PCV—positive crankcase ventilation
- 3.2.26 PID—parameter identification
- 3.2.27 PIE—preignition event
- 3.2.28 *P<sub>MAX</sub>*—maximum pressure (see **Note 5**)
- 3.2.29 *P<sub>MAXV</sub>*—pressure maximum voltage
- 3.2.30 *P<sub>MINV</sub>*—pressure minimum voltage
- 3.2.31 *PP*—peak pressure (see **Note 5**)
- 3.2.32 P/N—part number
- 3.2.33 *R*—reproducibility

iTeh Standards  
(<https://standards.itih.ai>)  
Document Preview

[ASTM D8291-21](https://standards.itih.ai/catalog/standards/sist/5dcefa52-3dc7-4655-be98-a857329aa00d/astm-d8291-21)

<https://standards.itih.ai/catalog/standards/sist/5dcefa52-3dc7-4655-be98-a857329aa00d/astm-d8291-21>

3.2.34 *S*—standard deviation

3.2.35 UCR—upper compression ring

3.2.36 VCT—variable valve timing

3.2.37 WOT—wide open throttle

3.2.38  $Z_r$ —exponentially weighted moving average

#### **4. Summary of Test Method**

4.1 The test procedure is a “flush and run” test, that is the test engine is used for multiple tests and the next test oil is used to flush the previous test oil from the engine.

4.2 The test procedure is conducted in four iterations. Each iteration is 175 000 engine cycles in length.

4.3 Low-engine speed and high-load, steady-state conditions are used to generate (*PIE*) events, which are counted throughout each of the four 175 000 engine cycles.

4.4 Combustion pressure is measured directly in each cylinder to provide documentary evidence of the occurrence of preignition events.

#### **5. Significance and Use**

5.1 This test method evaluates the ability of an automotive engine to mitigate preignition in the combustion chambers in turbocharged, direct injection, gasoline engines under low-speed and high-load operating conditions.

5.2 Varying quality reference oils, with known preignition tendencies, were used in developing the operating conditions of the test procedure.

5.3 The test method has applicability in gasoline-engine-oil specifications and is expected to be used in specifications and classifications of engine lubricating oils, such as the following:

5.3.1 Specification **D4485**.

5.3.2 ILSAC GF-6.

5.3.3 SAE Classification J183.

#### **6. Apparatus (General Description)**

6.1 *Test Engine*—The test engine is a spark-ignition, four-stroke, four-cylinder, gasoline, turbocharged, direct-injection engine with a displacement of 2.0 L. Features of this engine include variable camshaft timing, dual overhead camshafts driven by a timing chain, four valves per cylinder, and electronic direct-fuel injection. It is based on the Ford Motor Co. 2012 Explorer engine.<sup>6,7</sup>

6.2 Configure the test stand to accept the test engine. All special equipment necessary for conducting this test is listed below.

6.3 Use appropriate air-conditioning apparatus to control the temperature, pressure, and humidity of the inlet air to meet the requirements in **Table 1**.

<sup>6</sup> The sole source of supply of this component known to the committee at this time is Ford Motor Co., 290 Town Center Dr, Dearborn, MI 48126.

<sup>7</sup> If you are aware of alternative suppliers, please provide the information to ASTM International Headquarters. Your comments will receive careful consideration at a meeting of the responsible technical committee which you may attend.

TABLE 1 Oil-Flush-Procedure Conditions

Controlled Quantity, unit	Set Point
Coolant-out temperature, °C	95
Oil-gallery temperature, °C	95
Air-charge temperature, °C	43
Inlet-air temperature, °C	30
Inlet-air pressure, kPa (gauge)	0.05
Exhaust back pressure, kPa (absolute)	104
Humidity, g/kg	11.4
Fuel pressure, kPa	450 ± 37

6.4 Use an appropriate fuel supply system. A typical system is shown in Fig. 1.

NOTE 1—The fuel may need to be heated to maintain the fuel temperature in Table 1. As a consequence, heat may buildup in the fuel system during shutdown thereby increasing the pressure in the fuel lines. It is good practice, therefore, to include a pressure relief valve in the fuel line to relieve the pressure and to send the excess fuel back to the tank before the shutoff valve.

6.5 The control and data acquisition system shall meet the requirements listed in Annex A5.

6.6 Engine Cooling System:

6.6.1 Use the coolant-inlet and -outlet system from OH Technologies<sup>7,8</sup>. Typical plumbing for the external coolant system is shown in Fig. A6.2 and Fig. A6.3. Use a coolant flowmeter with an accuracy of ±1 %. Install the flowmeter at either the coolant inlet or coolant outlet sides of the engine. Install the flow control valve in the line running from the engine-coolant outlet to the heat exchanger. ITT standard heat exchangers<sup>7,9</sup> have been found suitable. Use 38 mm (1.5 in.) pipe to plumb the coolant system. Minimize the number of elbows in the cooling system. Ensure that the engine coolant flows through the tube side of the heat exchanger.

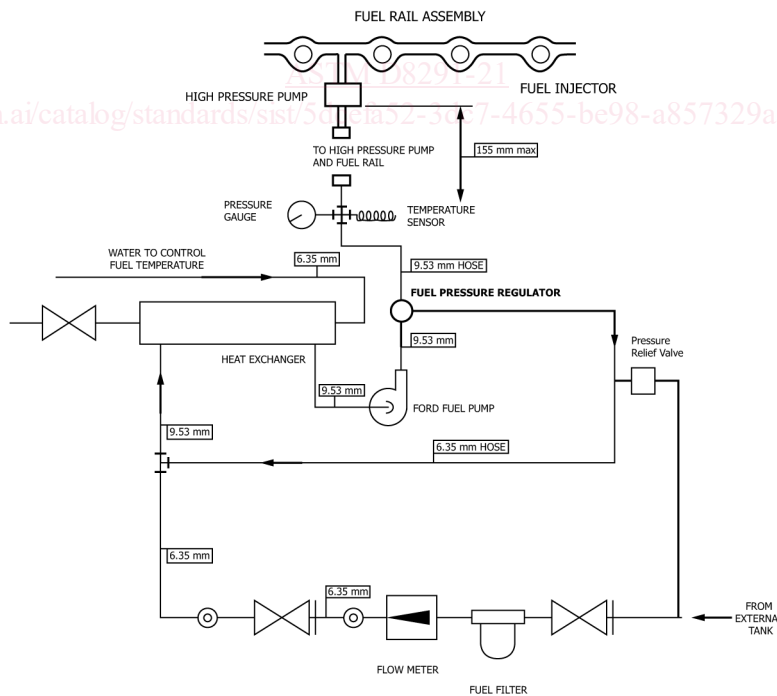

FIG. 1 Typical Fuel Supply System

<sup>8</sup> The sole source of supply of this part known to the committee at this time is OH Technologies, 9300 Progress Pkwy., Mentor, O 44060, USA.. Tel: +1 440 354 7007. www.ohtech.com.

<sup>9</sup> The sole source of supply of this part known to the committee at this time is Kinetics Engineering Corp., 2055 Silber Road, Suite 101, Houston, TX 77055.

6.6.2 A radiator cap is used to limit system pressure to 105 kPa. Motorcraft RS40 P/N D2YY8100-A<sup>7,10</sup> has been found suitable for this application. Pressurize the coolant system to 70 kPa  $\pm$  10 kPa at the top of the coolant reservoir.

6.6.3 Control the engine-coolant flow rate and outlet temperature to meet the requirements in [Table 1](#).

6.6.4 Inspect engine-coolant components external to the engine every three months and clean as necessary.

6.7 *Oil System Components*—All oil-system components in the engine are production configuration with the exception of the modified oil pan ([Fig. A6.1](#)) and oil-filter housing ([Fig. A6.12](#)).

6.8 Using the production oil cooler, control the oil temperature by running process water through the water side of the oil cooler. Locations of oil-temperature thermocouples are shown in [Fig. A6.12](#).

6.9 *Dynamometer*—Use Midwest dynamometer model MW-1014A.<sup>7,11</sup>

6.10 *Combustion Analysis Equipment*—Use the AVL IndiSmart GigaBit 612 combustion analysis system and the AVL IndiCom combustion analysis software.<sup>7,12</sup> For the latter, use the amplifier and pressure settings and the standard results settings given in [A4.1A10.1](#) and [A4.2A10.2](#), respectively. Report the channels shown in [A4.16A10.16](#).

6.11 *Fuel and Fuel System:*

6.11.1 *System Description*—[Fig. 1](#) is a schematic diagram of a typical fuel-supply system. Supply an excess volume of fuel to the high-pressure fuel pump and fuel rail at all times. Introduce make-up fuel (that is, fuel used by the engine) into the loop from an external source. Mix the makeup fuel with fuel that is returned from the fuel rail (that is, fuel not used by the engine). Pump the fuel through a mixing chamber, or a small heat exchanger, to mix the two streams and to provide fuel of consistent temperature to the engine. Deliver the fuel to a high-pressure pump (Ford P/N AG9Z-9350-B/AG9E-9D376-AB<sup>6,7</sup>) that boosts the pressure and supplies the fuel to the fuel rail.

6.11.2 *Controls*—Maintain the fuel temperature to the high-pressure pump at 30 °C  $\pm$  0.5 °C. To ensure good atomization of the fuel, maintain the fuel pressure to the high-pressure pump above 450 kPa  $\pm$  37 kPa. Maintain constant fuel pressure throughout the test to ensure good speed, power, and air-fuel ratio control.

6.11.3 *Test Fuel*—Approximately 340 L of Haltermann HF003 Lube Certification fuel<sup>7,13</sup> are required for each test. (**Warning**—Flammable, health hazard.)

6.11.4 *Fuel Batch*—Ensure each new batch of fuel is accompanied by a certificate of analysis showing that it meets the requirements shown in [Table A7.1—Test Fuel Specifications for TMC Monitored Tests](#), available from the ASTM Test Monitoring Center website: [www.astmtmc.org](http://www.astmtmc.org). Record the fuel batch identification number in the appropriate field in the test report. If co-mingling fuel batches, document the most prevalent fuel batch in the test report. There are no restrictions on the percentages of co-mingled batches but it is always a good practice to minimize the dilution.

6.11.4.1 Fuel from a new batch can be added to a laboratory's fuel tank at any time provided it meets the requirements [detailed in Table A7.1](#) the fuel specification (see also [6.11.4.2](#)).

6.11.4.2 *Fuel Batch Analysis*—Fuel shall be analyzed in accordance with industry standards. Refer to the recommendations of the Fuels Task Force which is a subgroup of the ASTM D02.B0 Technical Guidance Committee.

<sup>10</sup> Available from Ford dealership as well as select auto parts stores.

<sup>11</sup> Available from Dyne Systems, Inc. W209 N17391 Industrial Drive, Jackson, WI 53037 USA 800-657-0726; [dtnesystems.com](http://dtnesystems.com) and from Dyno One, Inc. 14671 N 250 W Edinburgh, IN 46124, [info@dyno-one.com](mailto:info@dyno-one.com). Tel 812-5260500.

<sup>12</sup> The sole source of supply of this system known to the committee at this time is AVL Gmbh, Platz 1, A-8020, Graz, Austria. [www.avl.com](http://www.avl.com).

<sup>13</sup> The sole source of supply of this fuel known to the committee at this time is Haltermann Products, 1201 Sheldon Road, P.O. Box 429, Channeview, TX 777530, USA. [www.haltermansolutions.com](http://www.haltermansolutions.com).

## 7. Apparatus (The Test Engine)

7.1 *Sequence IX Test Engine*—The test engine parts are available from the Ford Motor Company.<sup>6,7</sup> A detailed listing of all parts and P/Ns is given in [Annex A8A7](#).

7.2 *Required New Engine Parts*—A new short block is required when initially referencing a stand and engine combination. This short block can be re-used provided it remains within service limits and is capable of being referenced. New crush washers and gaskets are required whenever the engine/short block is disassembled (for example, for pretest measurements or repair). New camshafts and buckets are required when first building a cylinder head. New valves are required when rebuilding a cylinder head.

7.2.1 Use short blocks with installed pistons stamped with BB on the piston crown. Where BB stamped pistons are not installed, use pistons, part number AG9Z-6108-D<sup>14</sup>, stamped AA1 and AB1.

7.3 *Reusable Engine Parts*—The cylinder head can be used on subsequent short blocks as long as it remains within the service limits in the workshop manual. The parts listed in [Table A8-2A7.2](#), [Table A8-6A7.6](#), and [Table A8-7A7.7](#) can be used for multiple tests as long as they are in good condition and meet the service limits in the workshop manual.

7.4 *Specially Fabricated Engine Parts*—The following subsections detail the specially fabricated engine parts required in this test method:

7.4.1 *Inlet Air System* (see [Fig. A6.8](#))—Fabricate the inlet air system using the stock 2012 Explorer air cleaner assembly and mass air flow (MAF) sensor as detailed in [Table A8-6A7.6](#). Install the fresh-air tube, air-cleaner assembly, and new air filter. Modify the air-cleaner assembly to accept fittings for an inlet-air-temperature thermocouple and pressure tap. Either use the 2012 Explorer fresh-air tubes or fabricate fresh-air tubes so as to provide a separation of 1040 mm ± 25 mm from the MAF sensor to the turbocharger inlet.

7.4.2 *Oil Pan*—Modify the stock 2012 Explorer oil pan to add an oil drain plug in one of the rear locations shown in [Fig. A6.1](#).

7.4.3 *Cylinder Head*—Use a modified cylinder head that allows the installation of in-cylinder pressure sensors. This engine part is available from TEL.<sup>7,15</sup>

7.4.4 *Pressure Sensor Tubes*—Install 3/8 in. OD steel tubing into the pressure sensor sleeves in the cylinder head to allow for installation of the in-cylinder pressure sensors.

7.4.5 *Valve Cover*—Modify the stock valve cover to allow the pressure sensor tubes to protrude through the cover. Seal the location where the tubes protrude through the cover to prevent oil from leaking through the penetrations.

7.4.6 *Coolant Supply Manifold*—To accept the coolant-in thermocouple ([Fig. A6.2](#)), use a coolant inlet purchased from OH Technologies<sup>7,8</sup> in place of the stock coolant inlet.

7.4.7 *Coolant Return Manifold*—To accept the coolant-out thermocouple and provide a coolant return from the turbocharger ([Fig. A6.2](#)), use a coolant outlet purchased from OH Technologies<sup>7,8</sup> in place of the stock thermostat housing.

7.4.8 *Oil Filter Housing*—Modify the oil-filter housing to accept a thermocouple on the front side of the housing, facilitating measurement of the oil temperature entering the oil cooler.

7.5 *Special Engine Measurement and Assembly Equipment*—For assembly, use any special tools or equipment shown in the 2012 Explorer Service Manual. Complete any assembly instructions not detailed in Section 7 according to the instructions in the 2012 Explorer Service Manual. Apparatus routinely used in a laboratory or workshop are not included.

7.5.1 *Piston Ring Positioner*—Use the piston-ring positioner to locate the piston rings down from the cylinder-block deck surface by 38 mm. This allows the compression rings to be positioned in a consistent location in the cylinder bore for the ring-gap measurement. Fabricate the positioner according to the details shown in [Fig. A6.13](#).

<sup>14</sup> Available from any Ford dealer.

<sup>15</sup> Test Engineering Inc., 12758 Cimmaron Path, Ste. 102, San Antonio, TX 78249-3417.



7.5.2 *Engine Service Tools*—A list of special tools<sup>16</sup> for the test engine is shown in [Table A8.8A7.8](#). The tools are designed to aid carrying out several service items, in addition to the specific service items that require special tools to perform the functions indicated (if not self-explanatory).

#### 7.6 *Engine Installation on the Test Stand:*

7.6.1 *General*—Functions that are to be performed in a specific manner or at a specific time in the assembly process are noted here.

7.6.2 *Mounting the Engine on the Test Stand*—Mount the engine on the test stand so that the flywheel friction face is  $0.0^\circ \pm 0.5^\circ$  from vertical and at a  $0.0^\circ \pm 0.5^\circ$  roll angle. Use two motor mounts at the rear of the engine. Quicksilver P/N 66284-A<sup>7,17</sup> has been found suitable for this purpose. An example of a rear-mount support is shown in [Fig. A6.5](#). Use a rubber mount at the front of the engine attached to the front-cover mount. Examples of front-mount supports are shown in [Fig. A6.4](#). Ensure that the engine's longitudinal axis is aligned to within  $0.5^\circ$  of the dynamometer.

7.6.3 *Flywheel*—Obtain the modified flywheel (P/N OHTVH-006-1) from OH Technologies.<sup>7,8</sup> Lightly coat the flywheel bolts with Loctite 565 to prevent any oil from seeping out of the holes. Torque the flywheel to 108 N·m to 115 N·m.

7.6.4 *Clutch and Pressure Plate*—~~Obtain~~ Utilize the clutch (Sachs P/N K0047-07), disc (4-spring, Sachs P/N K0047-07<sup>18</sup> the pressure plate (P/N VH006-8-2), and spacer (P/N OVTVH-011-1) from OH Technologies, or ACT P/N 30000207.<sup>19</sup> Put the flat side on the clutch), and the pressure plate, Sachs P/N K0047-07.<sup>18</sup> toward the engine and put the spacer between the flywheel and pressure plate. Torque the pressure plate bolts to ~~25 N·m to 33 N·m.~~ 25 N·m to 33 N·m. Replace the clutch and pressure plate with every new engine.

7.6.5 *Driveline*—Grease the driveline every test. The driveline specifications are as follows:

- (1) Driveline angle degree:  $1.5^\circ \pm 0.5^\circ$ ;
- (2) Installed length from flange to flange: 450 mm to 610 mm;
- (3) 1410 series flanges; 1550 joints;
- (4) Driveshaft stiffness:  $0.1^\circ$  to  $0.3^\circ/136$  N·m (100 ft·lbf). P/N MSI-41/55S-22 from Machine Services Inc. (see [X1.5.2.3](#)) has been found to be a suitable driveshaft.

#### 7.7 *Exhaust System:*

7.7.1 **Warning**—Exhaust gas is noxious. (Caution: Any leaks in the connections to the sample probes will result in erroneous readings and incorrect air-fuel ratio adjustment.)

7.7.2 A typical exhaust system, with fittings for backpressure probe, oxygen (O<sub>2</sub>) sensors and thermocouple, is illustrated in [Fig. A6.6](#).

7.7.3 Construct exhaust components from either solid or bellows pipe/tubing. Other flexible pipe type is not acceptable.

7.7.4 Use the backpressure probes until they become unserviceable. If the existing probes are not cracked, brittle, or deformed, clean the outer surfaces and clear all port holes. Check the probes for possible internal obstructions and reinstall the probes in the exhaust pipe.

7.7.4.1 Stainless steel probes are generally serviceable for several tests; mild steel probes tend to become brittle after one test.

#### 7.8 *Fuel Management System:*

7.8.1 *Fuel Injectors*—Inspect the O-rings to ensure they are in good condition and will not allow fuel leaks. Replace if necessary. Install the fuel injectors into the fuel rail and the cylinder head.

#### 7.9 *Powertrain Control Module:*

<sup>16</sup> Available from any Ford dealership or from Owatonna Tools Co., 2013 4th St., NW Owatonna, MN 55060.

<sup>17</sup> The sole source of supply of this bracket known to the committee at this time is Quicksilver, [www.quicksilver-products.com](http://www.quicksilver-products.com).

<sup>18</sup> Available from online and local parts suppliers, contact Sachs website [www.sachsperformance.com](http://www.sachsperformance.com).

<sup>19</sup> Available from online and local parts suppliers, contact Advance Clutch Technology website [www.advancedclutch.com](http://www.advancedclutch.com).

7.9.1 Use a Powertrain Control Module (PCM) provided by Ford Motor Company<sup>6,7</sup> to run this test. The PCM contains a calibration developed for this test. The PCM calibration number is U502-HBBDJ0-v1-7-VEP-371.VBF.

7.9.1.1 The PCM is powered either by a 13.5 V ± 1.5 V battery or an alternative power supply that does not interrupt/interfere with proper PCM operation.

7.9.1.2 Connect the PCM battery/power supply to the engine wire harness with an appropriate gauge wire of the shortest practical length so as to maintain a dc voltage of 12 V to 15 V and minimize PCM electrical noise problems. Ground the PCM ground wire to the engine. From the same ground point, run a minimum 2 gauge wire back to the battery negative to prevent interruption/interference of the PCM operation. The power supply can also be used for the lambda (oxygen) sensors.

#### 7.10 Spark Plugs:

7.10.1 Use either Motorcraft CYFS-12-Y2<sup>10</sup> or Bosch (P/N HR7Mii30T<sup>20</sup>) spark plugs which come pre-gapped. Torque the spark plugs to 9 N·m to 12 N·m. Do not use anti-seize compounds on spark plug threads.

#### 7.11 Crankcase-Ventilation System:

7.11.1 The crankcase-ventilation system is vented to the atmosphere through the port in the valve cover and is not to be connected to the inlet.

#### 7.12 Water-to-Air Turbocharger Intercooler:

7.12.1 Use water-to-air intercooler capable of achieving the required air-charge temperatures in **Tables 1-4** and an average, system-pressure loss less than 3 kPa. Type 5 or Type 52 intercoolers from Frozenboost<sup>7,21</sup> have been found suitable.

When cleaning the intercooler as part of normal maintenance, spray clean the air side of the intercooler with solvent, rinse with hot water and leave to air-dry. Use commercial AquaSafe descaler to clean the water-side.

#### 7.13 Intercooler Tubing:

7.13.1 Fabricate the inlet-air system with 51 mm internal diameter (ID), stainless steel tubing from the turbocharger to the intercooler, and 64 mm ID, stainless steel tubing from the intercooler to the throttle body. The tubing length is not specified but should be the appropriate length to achieve the required air-charge temperature in **Table 1** and **Table 2** and an average system pressure loss less than 3 kPa.

7.13.1.1 Locate the sensors for measuring the Manifold Absolute Pressure and Temperature (MAPT) in accordance with **Fig. A6.9**. Place the probes for measuring the post-intercooler, turboboost pressure, and pre-intercooler pressures, in accordance with **Fig. A6.9**. A typical installation is shown in **Fig. A6.10**. The engine vacuum system is shown in **Fig. A6.15**.

#### 7.14 External Hose Replacement:

**TABLE 2 Sequence IX Controlled Quantities for the Eight-Hour Break-in**

Quantity, unit	Controlled value
Coolant-out temperature, °C	85
Oil-gallery temperature, °C	100
Inlet-air pressure, kPa (gauge)	0.05
Air-charge temperature, °C	37
Inlet-air temperature, °C	30
Humidity, g/kg	11.4
Fuel pressure, kPa	450 ± 37
Coolant flow rate	Valve wide open

<sup>20</sup> Available from retailers and autopart stores.

<sup>21</sup> FrozenBoost Inc., www.frozenboost.com.

**TABLE 3 Instrumentation Calibration Periods**

Instrument Type	Section	Calibration Period
Load cell	8.19	Prior to every reference test
Thermocouples	8.11	Every 3 mo
Pressure sensors	8.12	Every 3 mo
Flow meters	8.13	Every 3 mo
In-cylinder pressure sensors	8.16	Every 300 h
Crank angle encoder	8.17	Every 300 h
Charge amplifier	8.18	Manufacturer's recommendation

**TABLE 4 Oil-Flush Procedure**

Step	Time per Stage, h:min	Total Time, h:min	Ramp Time, h:min	Engine Speed, r/min	Engine Torque, N-m
1	0:02	0:02	-	Idle	0
2	0:15	0:17	0:02	2000	70
3	0:02	0:19	0:02	Ramp to idle	0

7.14.1 Inspect all external hoses used on the test stand and replace any hoses that have become unserviceable. Check for internal wall separations that could cause flow restrictions. Check all connections to ensure security.

#### 7.15 Wiring Harness:

7.15.1 There are two wiring harnesses used on the test stand—a dynamometer harness that connects to the stand power and PCM, and an engine harness. Obtain the dynamometer and engine-wiring harnesses from OH Technologies.<sup>7,8</sup> Diagrams of these wiring harnesses are shown in Fig. A6.16 and Fig. A6.17 identifying connections.

#### 7.16 Electronic Throttle Controller:

7.16.1 Control the electronic-throttle controller using signals from the simulated, accelerator-pedal position. The dynamometer wiring harness is supplied with an Accelerator Pedal Position jumper cable with un-terminated pigtail leads.

7.16.1.1 Connect the two voltage command signals, Acc Pos Sensor 1 and Acc Pos Sensor 2, to the Accelerator Pedal Position jumper cable. The voltage control ranges for each signal are shown in Table 5. The wiring schematic and pin-out description for this connection are shown in Fig. 2.

7.16.1.2 Acc Pos Sensor 2 shall always equal 50 % of Acc Pos Sensor 1.

7.16.1.3 Run the voltage signals through a voltage isolator otherwise interference will occur between the laboratory digital-to-analog converter (DAC) system and the engine electronic control unit (ECU) leading to erratic throttle control.

7.17 *Water Pump and Water-Pump Drive*—Install the water pump and pulley, the crankshaft pulley, and the tensioner according to the 2012 Explorer service manual. These are the only components needed to drive the water pump. All other production, front-end, accessory-drive components do not need to be installed. The engine cannot be used to drive any external engine accessory other than the water pump. Pull back the tensioner and install the water-pump drive belt as shown in Fig. 3. It is recommended that there is a minimum contact angle of 20° between the drive belt and the water-pump pulley.

**TABLE 5 Accelerator Position Sensor Control Ranges**

Command Signal	Operating Range, V <sup>A</sup>	Min Signal (Idle), V <sup>A</sup>	Max Signal (WOT), V <sup>A</sup>
Acc Pos Sensor 1	0 to 5.0	0.75 (15 %)	4.25 (85 %)
Acc Pos Sensor 2	0 to V	0.375 (15 %)	2.125 (85 %)

<sup>A</sup> DC.

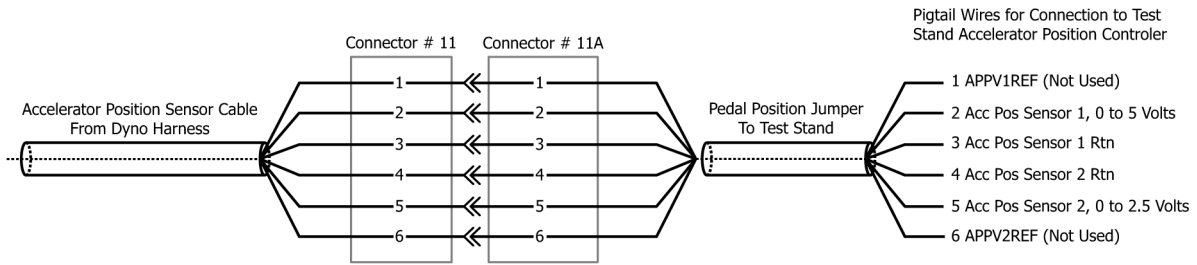

FIG. 2 Accelerator Position Wiring Schematic



FIG. 3 Water-Pump Drive Arrangement

7.18 *Cylinder-block Oil Separator:*

7.18.1 Install a dummy positive crankcase ventilation (PCV) valve (that is, a PCV valve with the internal components removed) in the oil separator on the side of the engine block. Measure crankcase pressure at this location.

**8. Engine Preparation**

8.1 *Environment for Engine Buildup and Measurement Areas*—The ambient atmosphere of the engine buildup and measurement areas shall be reasonably free of contaminants. Control the temperature to within  $\pm 3$  °C to ensure acceptable repeatability in the measurement of parts dimensions. To prevent moisture forming on cold engine parts that are brought into the buildup or measurement areas, maintain the relative humidity at a nominal maximum of 50 %.

8.2 *Engine Disassembly:*

8.2.1 Disassemble the engine and the cylinder head according to the 2.0 L EcoBoost disassembly procedures in the Ford 2012 Explorer Shop Manual. Note the position of all the engine components to ensure they are returned to the same positions when the engine is reassembled.

### 8.3 *Cleaning Engine Components:*

#### 8.3.1 *Cylinder Head Preparation and Cleaning:*

8.3.1.1 *General*—Use a modified cylinder head obtained from TEI.<sup>7,15</sup>

8.3.1.2 *New Cylinder Heads*—A new cylinder head that has been modified with pressure-transducer tubes installed, and never used in a previous Sequence IX test, shall be cleaned with Stoddard solvent before assembly. Clean all debris left from the tube installation off the cylinder head.

8.3.1.3 *Used Cylinder Heads*—For a cylinder head that has been modified with pressure transducer tubes installed, and has been used in a previous Sequence IX test, clean the bare cylinder head, with tubes (but no valve-train components) in an ultrasonic parts cleaner. Tierra Tech Model MOT500NS<sup>7,22</sup> has been found suitable for this purpose. Rinse parts with cleaning soap, NAT-50 or PDN-50,<sup>7,23</sup> before putting them into the ultrasonic cleaner. Use Ultrasonic Solution 7 and B<sup>7,22</sup> in the ultrasonic parts cleaner.

#### 8.3.1.4 *The Cleaning Procedure:*

(1) Heat the ultrasonic bath to 60 °C (140 °F). When this temperature is attained (but NOT before), add the ultrasonic cleaning solution. For the Tierra Tech Model MOT500NS with a capacity of 6000 L (158 gal), use 20.8 L of ultrasonic solution 7 and 1.9 L (0.5 gal) of ultrasonic solution B. Change the soap and water solution at least after every 25 h of use.

NOTE 2—Quantities will be different for a different size unit.

(2) After 30 min, remove the parts and immediately spray with hot water, followed by solvent and left to air dry.

8.3.2 *Cleaning Other Components*—Unless otherwise stated, spray clean the following components with solvent, then blow out with pressurized air, and leave to air dry:

- (1) camshafts and all valve train;
- (2) intake manifold/throttle body (unseparated);
- (3) fuel-pump housing with piston;
- (4) vacuum pump and oil screen;
- (5) oil screen and the intake and outlet of the turbocharger: wipe lightly, with a rag wet with solvent. (Do not clean the inside of the turbocharger);
- (6) carbon build up on the injectors: wipe off; variable valve timing;
- (7) variable valve timing (VCT) solenoids;
- (8) valve cover;
- (9) turbocharger oil lines.

### 8.4 *Engine Measurements:*

8.4.1 *Cylinder-Bore and Piston Measurements*—See [Table A9.1A8.1](#).

8.4.1.1 Measure and record the piston-to-bore clearances at the top-, second-, and third-ring lands and the piston skirt as shown in [Fig. A6.13](#). Use the bore ladder shown in [Fig. A6.14](#) to determine bore diameter positions. Measure the bore in both the longitudinal and transverse directions. To determine the piston-to-bore clearance, calculate the difference between the particular piston diameter location and the average bore diameter for both the transverse and longitudinal directions.

8.4.1.2 Measure and record ring side clearances for the upper and lower compression rings (UCR, LCR). Determine ring side clearance by taking four measurements 90° apart. Either check clearance with a thickness gauge or by measuring the difference between the thickness of the ring and the height of the corresponding groove.

8.4.1.3 Measure and record ring tension. Obtain ring tension measurements from Test Engineering, Inc.<sup>7,15</sup>

8.4.2 *Cylinder-head Measurements*—See [Table A9.2A8.2](#).

<sup>22</sup> The sole source of supply of this product known to the committee at this time is TierraTech, Draper Business Park, 12227 South Business Park Drive, Suite 100, Draper, UT 84020, sales@tierratech.com.

<sup>23</sup> The sole source of supply of this material known to the committee at this time is Better Engineering Manufacturing, 8361 Town Court, Baltimore, MD 21236.

8.4.2.1 To determine the valve stem-to-guide clearance, measure the diameter of the valve stem at 38 mm from the tip of the valve, and the valve guide at 19.5 mm from the top of the valve guide.

8.4.2.2 For the intake- and exhaust-valve springs, measure and record the spring free length and spring tension at a compressed height of 28.7 mm. Verify the compressed spring tension is  $460 \text{ N} \pm 21 \text{ N}$ . Reject any springs not meeting this criteria.

#### 8.5 *Miscellaneous Engine-Components Preparation:*

8.5.1 *Environment for Engine Buildup and Measurement Areas*—The ambient atmosphere of the engine buildup and measurement areas shall be reasonably free of contaminants. Control the temperature to within  $\pm 3 \text{ }^\circ\text{C}$  to ensure acceptable repeatability in the measurement of parts dimensions. To prevent moisture forming on cold engine parts that are brought into the buildup or measurement areas, maintain the relative humidity at a nominal maximum of 50 %.

#### 8.5.2 *Throttle Body:*

8.5.2.1 Clean the butterfly and bore of the throttle body with Berryman Chemtool B12<sup>7,24</sup> carburetor cleaner and air-dry before each test. Do not disassemble the throttle body as this will cause excessive wear on the components. The idle air screw can be removed for the cleaning process. Fully close the idle air screw during test operation.

8.5.2.2 There is no specific life for the throttle body. However, the clearance between the bore and the butterfly will eventually increase and render the body unserviceable. When the clearance becomes too great to allow control of speed, torque, and air-fuel ratio, discard the throttle body.

#### 8.6 *Engine Assembly:*

8.6.1 Assemble the engine according to the 2.0 L EcoBoost assembly procedures in the 2012 Explorer Shop Manual, except as noted in Section 7. Ensure all components (that is, pistons, rings, bearings, etc.) are replaced in the same positions used originally when assembled at the factory.

8.6.2 *Sealing Compounds*—Use a silicon-based sealer, as needed, on the contact surfaces between the rear-seal housing and oil pan and the front cover and cylinder block, cylinder head and oil pan. Use Motorcraft Gasket Maker (TA-16)<sup>7,10</sup> or equivalent between the sixth intake and exhaust camshaft cap and the cylinder head. Use silicon-based sealer sparingly since it can elevate the indicated silicon content of the used oil.

NOTE 3—Non-silicon liquid or tape thread sealers may be used on bolts and plugs.

8.6.3 *Gaskets and Seals*—Install new gaskets and seals during engine assembly.

#### 8.7 *Cylinder Head Assembly:*

8.7.1 Cylinder heads may be used as long as they remain within service specifications. Refer to the 2012 Explorer Service Manual.

8.7.2 Replace the valves on cylinder heads reused on another engine block.

8.7.3 If a cylinder head is removed from an engine block ahead of schedule due to broken pistons, short-block failure, or lack of test severity, the laboratory may reuse the cylinder head without replacing the valves provided they are within service limit.

8.7.4 Assemble the cylinder heads in accordance with the service manual. Lap the valves before installation and install new intake- and exhaust-valve seals. Set the valve lash in accordance with the procedure in the workshop manual and record the valve lash.

8.7.5 Vacuum check the valve ports before use.

8.8 *Engine Installation on Test Stand*—Install the engine onto the stand as described in 7.6.2. Install all engine components

<sup>24</sup> The sole source of supply of this product known to the committee at this time is Berryman Products, Inc, 3800 E. Randol Mill Rd, Arlington, TX 76011. Tel: +1 800 433 1704; www.berrymanproducts.com.

external to the long block according to the 2.0 L EcoBoost assembly procedures in the 2012 Explorer Shop Manual, where applicable. Connect the engine to all external laboratory systems identified in Section 6, in accordance with laboratory procedures.

8.9 *Pressure-Sensor Installation*—Once the sensor tubes and modified valve cover are installed (see 7.4.4 and 7.4.5), install pressure sensors into the pressure-sensor tube using the AVL type TT21 sensor-installation mounting tool (P/N TIWG0214A.01). Torque the sensors to 1.5 N·m.

8.10 *New-Engine Break In*—Once a new engine has been installed on the test stand, perform the eight-hour break-in procedure shown in Table 6 using oil TMC 220.<sup>25</sup>

8.10.1 The controlled quantities during the break-in are listed in Table 2. All other controls are left wide open or free flowing. The engine does not produce enough heat in the early steps to reach all target temperatures. All controlled quantities shall be on target at the beginning of Step 4.

8.11 *Temperature Measurements:*

8.11.1 *General:*

8.11.1.1 Temperature measurement locations are specified in 8.11.4.

8.11.1.2 Use thermocouples that can be calibrated with an accuracy of  $\pm 0.5$  °C. Use Ford-specified temperature sensors for Electronic Engine Control (EEC) inputs.

8.11.2 *Equipment:*

8.11.2.1 Use premium, sheathed thermocouples in all cases except the intake-air thermocouple which may be an open-tip type. Use thermocouples with a diameter of 3 mm. Locate all thermocouples in the center of the stream.

8.11.2.2 Thermocouples, wires, and extension wires shall be matched to perform in accordance with the special limits of error as defined in ANSI MC96.1.

8.11.3 *Calibration*—Refer to Table 3 for calibration interval of thermocouples. The temperature-measurement system shall indicate within  $\pm 0.5$  °C of the laboratory calibration standard. The calibration standard shall be traceable to NIST.<sup>26</sup>

<https://standards.iteh.ai/catalog/standards/sist/5dcefa52-3dc7-4655-be98-a857329aa00d/astm-d8291-21>

8.11.4 *Locations for Engine-Temperature Sensors:*

**TABLE 6 Sequence IX Eight-Hour, Break-In Procedure**

Step	Engine Speed, r/min	Engine Torque, N·m	Time per Stage, h:min	Total Time, h:min
Install new oil filter and charge engine with 4.2 kg of new oil				
1	1000 <sup>A</sup>	0	0:30	0:30
Oil change 1: Shut engine down, drain used oil, and remove oil filter. Allow oil to drain for 20 min. Install new oil filter and add 4.2 kg of new oil. Start engine and idle for 5 min				
2	1500	38	0:30	1:00
3	2000	72	0:30	1:30
4	2500	111	0:30	2:00
5	3000	135	0:30	2:30
6	3000	150	3:15	5:45
7	2000	72	0:15	6:00
8	3250	155	0:15	6:15
9	3500	155	0:15	6:30
10	3750	155	0:15	6:45
11	4000	155	1:15	8:00
Bring engine to idle speed for 5 min, then shut down Oil change 2: Drain used oil and remove oil filter. Allow oil to drain for 20 min. Install new oil filter and add 4.2 kg new oil.				

<sup>A</sup> Idle speed.

<sup>25</sup> Available from the ASTM Test Monitoring Center, 6555 Penn Avenue, Pittsburg, PA 15206-4489, Attention: Administrator.

<sup>26</sup> National Institute of Standards and Technology, 100 Bureau Drive, Stop 2300, Gaithersburg, MD 20899-2300. Email: calibrations@nist.gov. Phone: +1 301 975 2200.