



Designation: ~~E3081—16~~ E3081 – 21

Standard Practice for Outlier Screening Using Process Compensated Resonance Testing via Swept Sine Input for Metallic and Non-Metallic Parts¹

This standard is issued under the fixed designation E3081; the number immediately following the designation indicates the year of original adoption or, in the case of revision, the year of last revision. A number in parentheses indicates the year of last reapproval. A superscript epsilon (ϵ) indicates an editorial change since the last revision or reapproval.

1. ~~Scope~~ Scope*

1.1 This practice describes a general procedure for using the process compensated resonance testing (PCRT) via swept sine input method to perform outlier screening on populations of newly manufactured and in-service parts. PCRT excites the resonance frequencies of metallic and non-metallic test components using a swept sine wave input over a set frequency range. PCRT detects and analyzes component resonance frequency ~~patterns, patterns~~ and uses the differences in resonance patterns between acceptable and unacceptable components to perform non-destructive testing. PCRT frequency analysis compares the resonance pattern of a component to the patterns of known ~~acceptable and unacceptable~~ reference populations of the same ~~component, component~~ and renders a pass or fail result based on the similarity of the tested component to those populations. For non-destructive testing applications with known defects or material states of interest, or both, Practice ~~E2534~~ E2534 covers the development and application of PCRT sorting modules that compare test components to known acceptable and unacceptable component populations. However, some applications do not have physical examples of components with known defects or material states. Other applications experience isolated component failures with unknown causes or causes that propagate from defects that are beyond the sensitivity of the current required inspections, or both. In these cases, PCRT is applied in an outlier screening mode that develops a sorting module using only a population of presumed acceptable production components, and then compares test components for similarity to that presumed acceptable population. The resonance differences can be used to distinguish acceptable components with normal process variation from outlier components that may have material states or defects, or both, that will cause performance deficiencies. These material states and defects include, but are not limited to, cracks, voids, porosity, shrink, inclusions, discontinuities, grain and crystalline structure differences, density-related anomalies, heat treatment variations, material elastic property differences, residual stress, and dimensional variations. This practice is intended for use with instruments capable of exciting, measuring, recording, and analyzing multiple, whole body, mechanical vibration resonance frequencies in acoustic or ultrasonic frequency ranges, or both.

1.2 Units—The values stated in inch-pound units are to be regarded as standard. The values given in parentheses are mathematical conversions to SI units that are provided for information only and are not considered standard.

1.3 *This standard does not purport to address all of the safety concerns, if any, associated with its use. It is the responsibility of the user of this standard to establish appropriate ~~safety~~ safety, health, and health ~~environmental~~ environmental practices and determine the applicability of regulatory limitations prior to use. ~~Some specific hazards statements are given in Section 7 on Hazards.~~*

1.4 *This international standard was developed in accordance with internationally recognized principles on standardization established in the Decision on Principles for the Development of International Standards, Guides and Recommendations issued by the World Trade Organization Technical Barriers to Trade (TBT) Committee.*

¹ This ~~test method~~ practice is under the jurisdiction of ASTM Committee E07 on Nondestructive Testing and is the direct responsibility of Subcommittee E07.06 on Ultrasonic Method.

Current edition approved ~~Dec. 1, 2016~~ June 1, 2021. Published ~~December 2016~~ July 2021. Originally approved in 2016. Last previous edition approved in 2016 as E3081 – 16. DOI: ~~10.1520/E3081-16~~ 10.1520/E3081-21.

*A Summary of Changes section appears at the end of this standard

2. Referenced Documents

2.1 ASTM Standards:²

[E1316 Terminology for Nondestructive Examinations](#)

[E2001 Guide for Resonant Ultrasound Spectroscopy for Defect Detection in Both Metallic and Non-metallic Parts](#)

[E2534 Practice for Targeted Defect Detection Using Process Compensated Resonance Testing Via Swept Sine Input for Metallic and Non-Metallic Parts](#)

[E3213 Practice for Part-to-Itself Examination Using Process Compensated Resonance Testing Via Swept Sine Input for Metallic and Non-Metallic Parts](#)

3. Terminology

3.1 Definitions:

3.1.1 The definitions of terms relating to conventional ultrasonic examination can be found in Terminology [E1316](#).

3.2 Definitions:

3.2.1 *broadband, n*—the range of frequencies, excitation parameters, and data collection parameters developed specifically for a particular part type.

3.2.2 *classification, n*—the labeling of a teaching set of parts as acceptable or unacceptable.

3.2.3 *false negative, n*—part failing the sort but deemed by other method of post-test/analysis to have acceptable or conforming specifications.

3.2.4 *false positive, n*—part passing the sort but exhibiting a flaw (either inside the teaching set of flaws or possibly outside the teaching set range of flaws) or nonconforming to specification.

3.2.5 *margin part, n*—a single part representative of a part type that is used to determine measurement repeatability and for system verification.

3.2.6 *Process Compensated Resonant Resonance Testing (PCRT), n*—PCRT is a nondestructive examination method that enhances RUS with pattern recognition capability. PCRT more effectively discriminates resonance frequency shifts due to unacceptable conditions from resonance frequency shifts due to normal, acceptable manufacturing process variations. The process employs the swept sine measurement and analysis of acoustic or ultrasonic resonance frequency patterns, or both. PCRT pattern recognition tools identify the combinations of resonance patterns that most effectively differentiate acceptable and unacceptable components. In outlier screening applications, statistical scoring of the resonance frequencies is used to compare components of the presumed acceptable population, quantify process variation, and characterize component populations.

3.2.7 *quality factor (Q factor), n*—dimensionless property of resonance peak that describes the peak shape, that is, width relative to the peak center frequency; peaks with higher Q factor values are narrower and sharper.

3.2.8 *resonance spectra, n*—the recorded collection of resonance frequency data, including frequency peak locations and the characteristics of the peaks, for a particular part.

3.2.9 *Resonant Ultrasound Spectroscopy (RUS), n*—Basic RUS was originally applied in fundamental research applications in physics and materials science (1)³. Other recognizable names include acoustic resonance spectroscopy, acoustic resonant inspection, and resonant inspection. Guide [E2001](#) documents RUS extensively. RUS is a nondestructive examination method that employs the measurement and analysis of acoustic or ultrasonic resonance frequencies, or both, for the identification of acceptable variations in the physical characteristics of test parts in production environments. In this procedure an isolated, rigid component is excited, producing oscillation at the natural frequencies of vibration of the component. Diagnostic resonance frequencies are measured and compared to resonance frequency patterns previously defined as acceptable. Based on this comparison, the part is judged to be acceptable or, if it does not conform to the established pattern, unacceptable.

² For referenced ASTM standards, visit the ASTM website, www.astm.org, or contact ASTM Customer Service at service@astm.org. For *Annual Book of ASTM Standards* volume information, refer to the standard's Document Summary page on the ASTM website.

³ The boldface numbers in parentheses refer to the list of references at the end of this standard.

3.2.10 *sort, n*—for outlier screening applications, a software program capable of classifying a component as acceptable or outlying.

3.2.11 *teaching set, n*—for outlier screening applications, a group of like components including examples of only presumed acceptable production components representative of the range of acceptable variability.

3.2.12 *work instruction, n*—stepwise instructions developed for each examination program detailing the order and application of operations for PCRT examination of a part.

4. Summary of Practice

4.1 Introduction:

4.1.1 Many variations on resonance testing have been applied as nondestructive examination tools to detect structural anomalies that significantly alter component performance. The details of this basic form of resonance testing are outlined in Guide [E2001](#).

4.1.2 Process Compensated Resonance Testing (PCRT) is a progressive development of the fundamental principles of RUS, and can employ various methods for enhancing the discrimination capability of RUS. Throughout the 1990s, application of RUS for production NDT led to better understanding of the challenges associated with differentiating resonance variations caused by structural anomalies from resonance variations from normal and acceptable process variation in mass, material properties and dimensions (2), (3). PCRT first became commonly used in the production examination of metal and ceramic parts in the late 1990s (4). By the early 2000s, PCRT had essentially developed into the robust NDT capability it is today (5).

4.1.3 PCRT is a comparison technology using a swept sine wave to excite the components through a range of resonance frequencies determined by the part's mass, geometry, and material properties. In outlier screening applications, the resonance spectrum is then compared to resonance spectra for presumed acceptable components. The database of presumed acceptable components is established through the collection of a teaching set of components that represent the range of acceptable process variation. PCRT outlier screening applications are taught to be insensitive to variations associated with acceptable components and identify resonance variations that indicate outlier components. PCRT outlier screening can use Z-score statistical analysis of frequencies for a large number of resonance modes to determine frequency averages and frequency deviation and set limits for each value. A component that exceeds either the frequency average or frequency deviation limits is flagged as outlier. PCRT outlier screening can also use pattern recognition and statistical scoring using the Mahalanobis-Taguchi System (MTS) to evaluate a test component for similarity to the training population using a smaller number of resonance modes. A component that exceeds the MTS-based limits is flagged as an outlier. In one examination cycle, PCRT-based outlier screening can identify outlier parts that may contain a single anomaly or combinations of anomalies, as listed in 1.1. The PCRT measurement yields a ~~whole-body~~ whole-body response, finding ~~structurally-significant~~ structurally significant anomalies anywhere within the part, but it is generally not capable of determining the type or location of the anomaly.

4.1.4 PCRT outlier screening can be applied to new parts in the production environment, to parts currently in service, or in a combined program in which parts are initially classified as free of substantial anomalies in production, and then periodically re-examined with PCRT in order to monitor for the accumulation of fatigue and damage resulting from use. The process for using frequency changes between different points in time to perform NDT and process monitoring and control is described in more detail in Practice [E3213](#). One example of a PCRT outlier screening application is gas turbine engine blades. Outlier screening is used to detect material anomalies and conditions resulting from out-of-control manufacturing processes for new production blades. For in-service blades, outlier screening detects unexpected side effects from repair processes and non-repairable conditions from in-service aging/damage.

4.1.5 This practice is intended to provide a practical guide to the application of PCRT-based outlier screening to metallic and non-metallic parts. It highlights the steps necessary to produce robust and accurate test applications and outlines potential weaknesses, limitations and factors that could lead to misclassification of a part. Some basic explanations of resonances, and the effects of anomalies on them, are found in 4.2. Some successful applications and general description of the equipment necessary to successfully apply PCRT for classification of production parts are outlined in 5.1 and 5.2, respectively. Additionally, some constraints and limitations are discussed in 5.3. The general procedure for developing a part-specific PCRT application is laid out in 6.1.

4.2 Resonance and the Effect of ~~Anomalities~~:Anomalies:

4.2.1 The swept sine method of vibration analysis operates by driving a part at given frequencies (acoustic through ultrasonic, depending on the part characteristics) and measuring its mechanical response. Fig. 1 contains a schematic for one embodiment of a PCRT apparatus. The swept sine wave proceeds in small frequency steps over a previously determined broadband frequency range of interest. When the excitation frequency is not matched to one of the part’s resonance frequencies, very little energy is coupled to the part; that is, there is essentially no vibration. At resonance, however, the energy delivered to the part is coupled, generating much larger vibrations. A part’s resonance frequencies are determined by its geometry, density, and material elastic constants (mechanically equivalent to mass, stiffness, and damping) of the material. An example of the resonance spectra for a part is shown in Fig. 2 for reference.

4.2.2 If a structural anomaly, such as a crack, is introduced into a region under strain, it will change the effective stiffness of a part (decrease stiffness for a crack). That is, the part’s resistance to deformation will change and will shift some of the part’s resonant frequencies (downward for decreasing stiffness). Voids in a region can reduce mass and increase certain resonant frequencies. In general, any change to a part that alters the structural integrity, changes a geometric feature or affects the material properties will alter its natural resonance frequencies. Graphic examples of the effects of various anomalies on resonances are presented in Guide E2001.

4.2.3 For example, the torsional (twisting) (Fig. 3) resonant modes represent a twisting of a part about its axis. In the simple example of a long cylinder, these resonances are easily identified because some of their frequencies remain constant for a fixed length, independent of diameter. A crack will reduce the ability of the part to resist twisting, thereby reducing the effective stiffness, and thus, the frequency of a torsional mode both shifts to a lower value and then alters the mode shape. Other resonances representing different resonance mode shapes of the part will not be affected in the same manner. Also, a large structural anomaly can be detected readily by its effect on the first few resonant frequencies. However, smaller structural anomalies have much more subtle and localized effects on stiffness, and therefore, often require higher frequencies (high-order resonant modes and harmonics) to be detected. In general, it must be remembered that most parts will exhibit complex motions when resonating. Analyzing the relationship between the resonant frequencies provides one way to generate the information necessary to interpret the data resulting from measuring the frequencies of the various resonant modes. These relationships form one basis for detecting the difference between normal, expected variations and variations indicating significant structural or geometric differences from one part to another. A broad body of research is available, describing various other nonproprietary approaches to identifying significant features (flaws, damage, etc) from changes in their vibration characteristics in the presence of environment or process variation (6).

5. Significance and Use

ASTM E3081-21

5.1 PCRT Applications and Capabilities—Capabilities—PCRT has been applied successfully to a wide range of outlier screening applications in the manufacture and maintenance of metallic and non-metallic parts. Examples of anomalies detected are discussed in 1.1. PCRT has been shown to provide cost effective and accurate outlier screening solutions in many industries including automotive, aerospace, and power generation. Examples of successful applications currently employed in commercial use include, but are not limited to:

- (1) Silicon nitride bearing elements,
- (2) Steel, iron, and aluminum rocker and control arms,

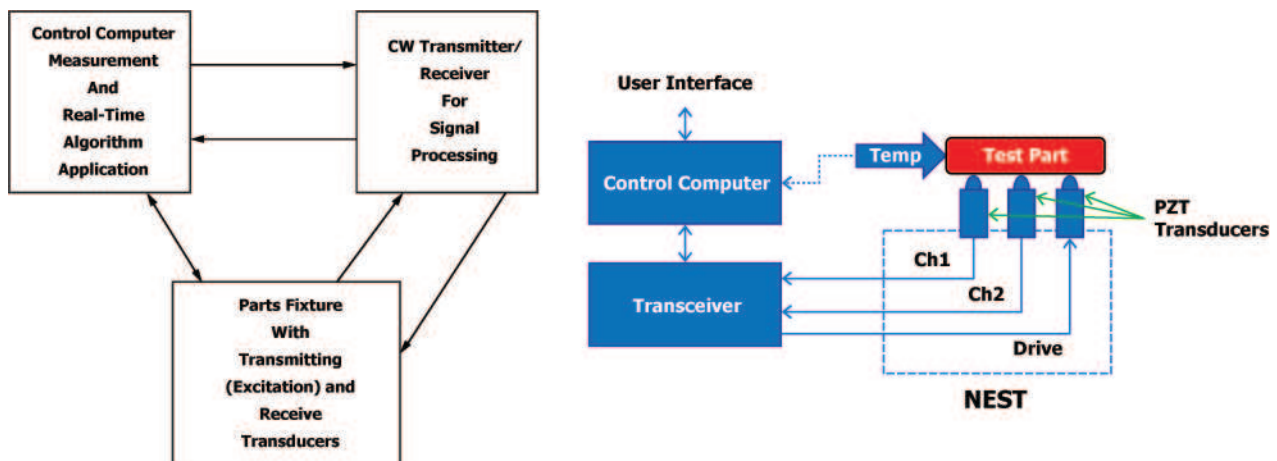

FIG. 1 PCRT System Schematic

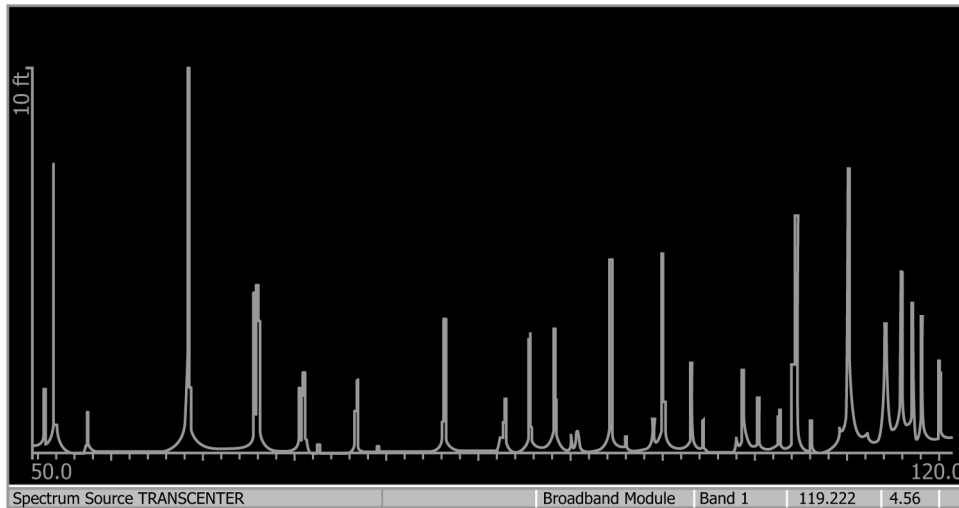

FIG. 2 Resonance Spectra (50 kHz to 120 kHz)

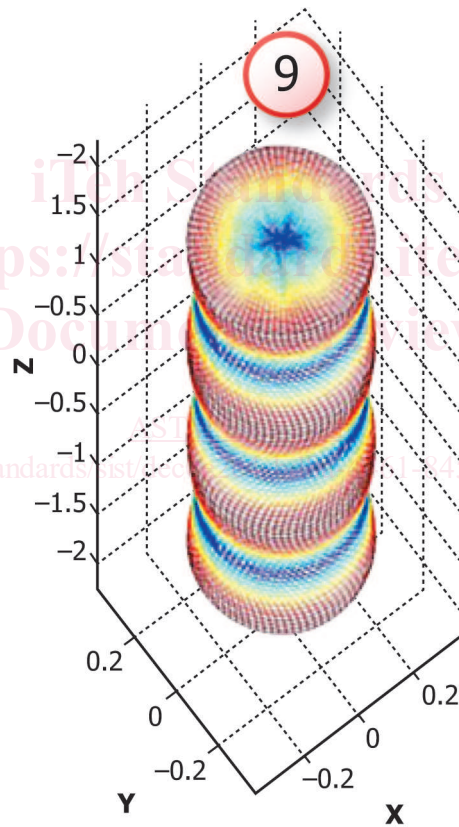

FIG. 3 Torsional Mode for Cylinder

- (3) ~~Gas~~-Aircraft and industrial gas turbine engine components (blades, vanes, disks),
- (4) Cast cylinder heads and cylinder blocks,
- (5) Sintered powder metal gears and clutch plates,
- (6) Machined forged steel steering and transmission components (gears, shafts, racks),
- (7) Ceramic oxygen sensors,
- (8) Silicon wafers,
- (9) ~~Gears~~-Gears, including those with induction hardened or carburized teeth,
- (10) Ceramic matrix composite (CMC) material samples and components,
- (11) Components with shot peened surfaces,
- (12) Machined ~~and/or~~ or rolled-formed steel fasteners, ~~and or~~ both.

- ~~(13) Additive manufactured components.~~ Components made with additive manufacturing,
- ~~(14) Aircraft landing gear, wheel and brake components, and~~
- ~~(15) Components made with metal injection molding.~~

5.2 General Approach and Equipment Requirements for PCRT via Swept Sine Input:

5.2.1 PCRT systems are comprised of hardware and software capable of inducing swept sine vibrations, recording the component response to the induced vibrations, and executing analysis of the data collected. Inputting a swept sine wave into the part has proven to be an effective means of introducing mechanical ~~vibration,~~ vibration and can be achieved with a high quality signal generator coupled with an appropriate active transducer in physical contact with the part. Collection of the part's frequency response can be achieved by recording the signal generated by an appropriate passive vibration transducer. The software required to analyze the available data may include a variety of suitable statistical analysis and pattern recognition tools. Measurement accuracy and repeatability are extremely important to the application of PCRT.

5.2.2 *Hardware Requirements*—A swept sine wave signal generator and response measurement system operating over the desired frequency range of the test part are required with accuracy better than 0.002 %. The signal generator should be calibrated to applicable industry standards. Transducers must be operable over same frequency range. Three transducers are typically used; one “drive” transducer and two “receive” transducers. Transducers typically operate in a dry environment, providing direct contact coupling to the part under examination. However, noncontacting response methods can operate suitably when parts are wet or oil-coated. Other than fixturing and transducer contact, no other contact with the part is allowed as these mechanical forces dampen certain vibrations. For optimal examination, parts should be placed precisely on the transducers (generally, ± 0.062 in. (1.6 mm) in each axis provides acceptable results). The examination nest and cabling shall isolate the drive from receive signals and ground returns, so as to not produce (mechanical or electrical) cross talk between channels. Excessive external vibration or audible noise, or both, will compromise the measurements.

5.3 Constraints and Limitations:

5.3.1 PCRT cannot separate parts based on visually detectable anomalies that do not affect the structural integrity of the part. It may be necessary to provide additional visual inspection of parts to identify these indications.

5.3.2 Excessive process variation of parts may limit the sensitivity of PCRT outlier screening.

5.3.3 Specific anomaly identification is highly unlikely. PCRT is a whole body measurement, ~~and so~~ differentiating between a crack and a void in the same location is generally not possible. It may be possible to differentiate some anomalies by using multiple patterns and teaching sets. The use of physics-based modeling and simulation to predict the resonance frequency spectrum of a component may also allow relationships between resonance frequencies and defect locations/characteristics to be established.

5.3.4 PCRT will only work with stiff objects that provide resonances whose peak quality factor (Q) values are greater than 500. Non-rigid materials or very thin-walled parts may not yield satisfactory Q values.

5.3.5 While PCRT can be applied to painted and coated parts in many cases, the presence of some surface coatings such as vibration absorbing materials and heavy oil layers may limit or preclude the application of PCRT.

5.3.6 While PCRT can be applied to parts over a wide range of temperatures, it ~~cannot~~ should not be applied to parts that are rapidly changing temperature. The part temperature should be stabilized before collecting resonance data.

5.3.7 Misclassified parts in the teaching set, along with the presence of unknown anomalies in the teaching set, can significantly reduce the accuracy and sensitivity of PCRT.

6. Procedure

6.1 Successful PCRT application development and implementation follows a standard flow. The stepwise functions required in the flow are:

- (1) Collection of a teaching set of components,
- (2) Design and fabrication of a test nest or appropriate fixturing,
- (3) An understanding of the effects of temperature on the resonance spectra,
- (4) Specification of a resonance broadband data collection parameters,

- (5) Evaluation of system measurement repeatability and reproducibility (similar to Gauge R and R) with respect to mounting parameters,
- (6) Collection of data from the teaching set of parts,
- (7) Analysis of collected data for pattern recognition,
- (8) Generation of a sort to classify examined parts,
- (9) Validation of the sort against the teaching set components and unknown components,
- (10) Issuance for the work instruction for the specific part,
- (11) Validation of work instructions and technician training against control set of components, and
- (12) Execution of the work instruction for component examination.

6.1.1 *Collection of Teaching Set Parts*—The collection of the initial teaching set of components is critical to the successful application of PCRT outlier screening. The teaching set must represent the range of acceptable variation in the part appropriate to the intended state of the parts to be examined. While it is possible to add additional acceptable parts to the teaching set over time, it is most desirable to have full range of representation of acceptable variability from the onset of the project. The total number of parts required for the teaching set varies as a function of the range of acceptable variations present. A guideline however is that roughly 100 acceptable components is the minimum for most outlier screening applications. Processes that produce tightly controlled parts with small acceptable variations may allow a smaller teaching set, while a process with a wide range of acceptable variation may require a larger teaching sets. Teaching set components that exhibit visual or quantitative differences from the rest of the population should be excluded from the presumed acceptable population.

~~6.1.1.1 *Characterization of Outlier Parts by NDT*—Other NDT techniques such as magnetic particle, dye penetrant, X-ray, eddy current, ultrasound, computed tomography, SONIC IR, Flash Thermography, and visual inspection can be useful for characterization of outlier parts identified by outlier screening.~~

~~6.1.1.2 *Characterization of Outlier Parts by Destructive Examination*—Destructive methods, including, but not limited to, static and dynamic functional examination, sectioning, and metallographic analysis, have proven to be the best tools for characterization of outlier parts identified by PCRT outlier screening.~~

6.1.2 *Design and Fabrication of Test Nest*—Because the nest on which testing is performed and data is collected defines the boundary conditions for the resonating part, care must be taken in its design to ensure accurate and repeatable location of the part relative to the transducers and support. While optimal nest design is often experimentally determined, the following objectives give direction to the experimentation:

- (1) Position the driven transducer in an area of the part with significant mass to ensure adequate coupling of the transducer to the part.
- (2) If multiple receive transducers are used, place them at different distances from the drive transducer, and attempt to have each carry a similar portion of the part's weight.
- (3) The fixture should be isolated from vibrations induced by the operating environment.
- (4) Ease of part placement and protection of transducers in operation should be considered in the design.
- (5) If multiple nests are to be used to examine a single part type, the nests must be confirmed to produce comparable results for a given input.
- (6) For parts up to about 45 lb (20.41 kg), the common practice is to support the part on the drive transducer and receiving transducers (see Fig. 4 and Fig. 5).
- (7) For heavier objects, it is often more practical to support the part on some isolating material and to contact the part with the drive and receiving transducers, often lowered into contact from the top.

6.1.3 *Understanding Effects of Temperature on Resonance Spectra*—While PCRT can perform over the wide range in temperatures encountered in the manufacturing and operating environments, care must be taken to ensure that data quality is not adversely affected by temperature effects. Because the resonances of materials vary with changes in temperature, it is important that the effect of temperature on a particular part's spectra is well understood. It is also important to ensure that the part is at a stable temperature during data collection and examination. At least one method of compensating for the effects of temperature on the resonance spectra of parts is covered under U.S. patents.

6.1.4 *Specification of Resonance Broadband and Data Collection Parameters*—Each part type will have a range of frequencies relevant to PCRT based on the part's mass, geometry, and material properties. An aluminum or steel part of 1 lb (0.45 kg) is likely to may have a useful frequency range of up to ±30 kHz, 200 kHz or greater, whereas a steel part of 25 lb (11.34 kg) is likely to may have a frequency range of up to 50 kHz. Special applications such as ceramic roller elements may require frequencies above the 500 kHz to 10 MHz range. With the range of frequencies determined, the excitation and data collection parameters must be optimized throughout that range to ensure accurate and repeatable data is collected.