



Designation: ~~D1838~~—~~20~~ D1838 – 21

## Standard Test Method for Copper Strip Corrosion by Liquefied Petroleum (LP) Gases<sup>1</sup>

This standard is issued under the fixed designation D1838; the number immediately following the designation indicates the year of original adoption or, in the case of revision, the year of last revision. A number in parentheses indicates the year of last reapproval. A superscript epsilon ( $\epsilon$ ) indicates an editorial change since the last revision or reapproval.

### 1. Scope\*

1.1 This test method covers the detection of the presence of components in liquefied petroleum gases which can be corrosive to copper.

NOTE 1—For an equivalent copper strip test applicable to less volatile petroleum products, see Test Method [D130](#).

1.2 The values stated in SI units are to be regarded as standard.

1.2.1 *Exception*—The values given in parentheses are for information only.

1.3 *This standard does not purport to address all of the safety concerns, if any, associated with its use. It is the responsibility of the user of this standard to establish appropriate safety, health, and environmental practices and determine the applicability of regulatory limitations prior to use.* For specific warning statements, see [7.1](#), [10.3.1](#), and [Annex A1](#).

1.4 *This international standard was developed in accordance with internationally recognized principles on standardization established in the Decision on Principles for the Development of International Standards, Guides and Recommendations issued by the World Trade Organization Technical Barriers to Trade (TBT) Committee.*

### 2. Referenced Documents

[ASTM D1838-21](#)

<https://standards.iteh.ai/catalog/standards/sist/9aa4ed45-7ec3-4521-9acf-850ad2b377a6/astm-d1838-21>

2.1 *ASTM Standards*:<sup>2</sup>

[D130 Test Method for Corrosiveness to Copper from Petroleum Products by Copper Strip Test](#)

[D1265 Practice for Sampling Liquefied Petroleum \(LP\) Gases, Manual Method](#)

[D1835 Specification for Liquefied Petroleum \(LP\) Gases](#)

[D3700 Practice for Obtaining LPG Samples Using a Floating Piston Cylinder](#)

2.2 *ASTM Adjuncts*:

[ADJD0130, ASTM Copper Strip Corrosion Standard for Petroleum](#)<sup>3</sup>

### 3. Terminology

3.1 *Abbreviations*:

3.1.1 *CAMI*—Coated Abrasives Manufacturers Institute

<sup>1</sup> This test method is under the jurisdiction of ASTM Committee [D02](#) on Petroleum Products, Liquid Fuels, and Lubricants and is the direct responsibility of Subcommittee [D02.H0](#) on Liquefied Petroleum Gas.

Current edition approved July 1, 2020/July 1, 2021. Published July 2020/July 2021. Originally approved in 1961. Last previous edition approved in 2016/2020 as ~~D1838-16~~ [D1838-20](#). DOI: ~~10.1520/D1838-20~~ [10.1520/D1838-21](#).

<sup>2</sup> For referenced ASTM standards, visit the ASTM website, [www.astm.org](http://www.astm.org), or contact ASTM Customer Service at [service@astm.org](mailto:service@astm.org). For *Annual Book of ASTM Standards* volume information, refer to the standard's Document Summary page on the ASTM website.

<sup>3</sup> Available from ASTM International Headquarters. Order Adjunct No. [ADJD0130](#).

\*A Summary of Changes section appears at the end of this standard

3.1.2 FEPA—Federation of European Producers Association

**4. Summary of Test Method**

4.1 A polished copper strip is immersed in approximately 100 mL of the sample and exposed at a temperature of 37.8 °C (100 °F) for 1 h in a cylinder of suitable working pressure. At the end of this period, the copper strip is removed and rated as one of the four classifications of the ASTM Copper Strip Corrosion Standard (ADJD0130).

**5. Significance and Use**

5.1 Copper corrosion limits provide assurance that difficulties will not be experienced in deterioration of the copper and copper-alloy fittings and connections that are commonly used in many types of utilization, storage, and transportation equipment.

**6. Apparatus**

6.1 *Corrosion Test Cylinder*, constructed of stainless steel with an O-ring removable top closure according to the dimensions given in Fig. 1. Provide a flexible inert hose, such as one composed of aluminum or stainless steel, which permits inverting the test cylinder as required in the procedure (see 6.1.1). The whole assembly, including the corrosion test cylinder, shall be constructed to withstand a minimum hydrostatic test pressure of 6900 kPa (1000 psig). No leak shall be discernible when tested at 3450 kPa (500 psig) with gas.

6.1.1 Swivel connections with an adapter to fit a 6.4 mm (1/4 in.) pipe may be used.

6.1.2 The assembly shall be tested for compliance with the minimum pressure rating of 6900 kPa (1000 psig) by hydrostatic testing, or alternative testing protocol acceptable to the local authority having jurisdiction, prior to first use. Additional testing can be required by the local authority having jurisdiction.

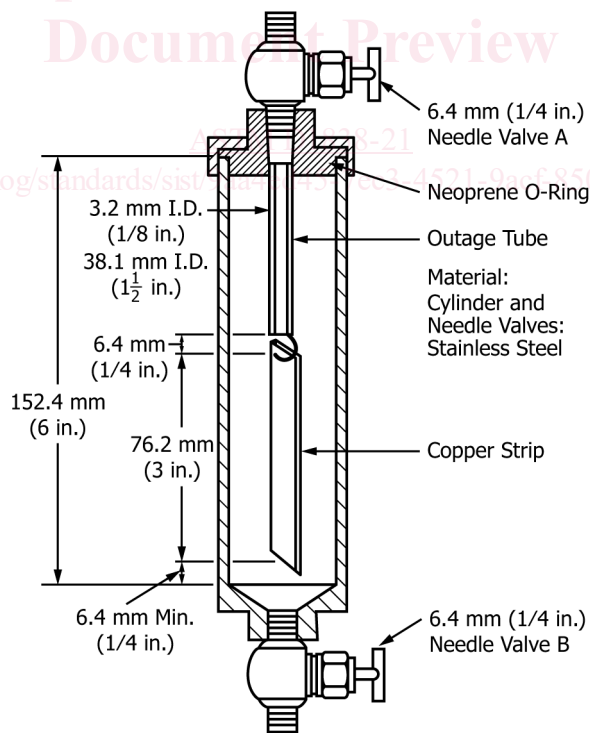

Metric Equivalents

in.	mm	in.	mm
1/8	3.2	3	76
1/4	6.4	6	152
1/2	38.1		

**FIG. 1 Copper Strip Corrosion Test Cylinder**

6.1.3 The assembly shall be verified for gas tightness by leak testing at a minimum of 3450 kPa (500 psig) with inert gas prior to first use, whenever pressure-containing components of the assembly are replaced, or otherwise on an annual basis.

6.1.4 Note the presence and length (about 60 mm) of the outage tube shown in Fig. 1, to provide adequate ullage for safety. A safety pressure relief device may also be incorporated into the design of the corrosion test cylinder, if desired. If a pressure relief device is incorporated, ensure that the materials of its construction will not affect the test results.

6.2 *Water Bath*, capable of being maintained at  $37.8\text{ }^{\circ}\text{C} \pm 0.5\text{ }^{\circ}\text{C}$  ( $100\text{ }^{\circ}\text{F} \pm 1\text{ }^{\circ}\text{F}$ ). Incorporate suitable supports to hold the test cylinder in an upright position. Make the bath deep enough so that the entire cylinder and valves will be covered during the test.

6.3 *Temperature Sensing Device (TSD)*—Capable of monitoring the desired test temperature in the bath to within an accuracy of  $\pm 0.5\text{ }^{\circ}\text{C}$  ( $1\text{ }^{\circ}\text{F}$ ) or better.

6.4 *Strip Polishing Vise*, to hold the copper strip firmly without marring the edges. For convenient vises see Test Method D130.

## 7. Materials

7.1 *Wash Solvent*—Any volatile, less than 5 mg/kg sulfur, hydrocarbon solvent may be used provided that it shows no tarnish at all when tested for 3 h at  $50\text{ }^{\circ}\text{C}$  ( $122\text{ }^{\circ}\text{F}$ ). 2,2,4-trimethylpentane (~~isooctane~~)(*isooctane*) of minimum 99.75 % purity is the referee solvent and should be used in case of dispute. (**Warning**—Extremely flammable, see Annex A1.)

7.2 *Copper Strip Specification*—Use strips that are  $12.5\text{ mm} \pm 2\text{ mm}$  ( $1/2\text{ in.}$ ) wide, 1.5 mm to 3.2 mm ( $1/16\text{ to }1/8\text{ in.}$ ) thick, and cut  $75\text{ mm} \pm 5\text{ mm}$  (3 in.) long from smooth-surfaced, hard-temper, cold-finished copper of 99.9+ % purity; electrical bus bar stock is generally suitable. Drill a 3.2 mm ( $1/8\text{ in.}$ ) hole approximately 3.2 mm ( $1/8\text{ in.}$ ) from one end in the center of the strip. The strips may be used repeatedly but shall be discarded when the strip's surface shows pitting or deep scratches that cannot be removed by the specified polishing procedure, or when the surface becomes deformed, or the dimensions for the copper strip fall outside the specified limits.

7.3 *Surface Preparation/Polishing Materials*—00 grade or finer steel wool; silicon carbide grit paper or cloth of varying degrees of fineness including 65  $\mu\text{m}$  grade (220-grit CAMI-grade or P220 FEPA-grade); also a supply of 105  $\mu\text{m}$  (120-grit to 150-grit CAMI-grade or P120 to P150 FEPA-grade) size silicon carbide grain or powder and absorbent cotton. A commercial grade is suitable, but pharmaceutical grade cotton wool is most commonly available and is acceptable.

7.4 *ASTM Copper Strip Corrosion Standard (ADJD0130)*, Plaques are available.<sup>3</sup> Their care and inspection for stability are described in detail in Test Method D130.

7.5 *Reagent Grade LPG*—Propane, butane, or mixture of propane and butane that has less than 1 mg/kg sulfur and passes this copper corrosion test with a No. 1 rating.

## 8. Preparation of Strips

8.1 *Surface Preparation*—Remove all surface blemishes from all six sides of the strip obtained from a previous analysis. One way to accomplish this is to use 00 grade or finer steel wool or silicon carbide paper or cloth of such degrees of fineness as are needed to accomplish the desired results efficiently. Finish with 65  $\mu\text{m}$  grade (220-grit CAMI-grade or P220 FEPA-grade) silicon carbide paper or cloth, removing all marks that could have been made by other grades of paper used previously. Ensure the prepared copper strip is protected from oxidation prior to final preparation, such as by immersing the strip in wash solvent from which it can be withdrawn immediately for final preparation (polishing) or in which it can be stored for future use.

~~8.1.1 Only final preparation (8.2) is necessary for commercially purchased pre-polished strips.~~

8.1.1 As a practical manual procedure for surface preparation, place a sheet of silicon carbide paper or cloth on a flat surface and moisten it with wash solvent. Rub the strip against the silicon carbide paper or cloth with a circular motion, protecting the strip from contact with the fingers by using ashless filter paper or wearing disposable gloves. Alternatively, the surface of the strip may be prepared by use of motor-driven machines using appropriate grades of dry paper or cloth.

8.1.2 Only final preparation (8.2) is necessary for commercially purchased pre-polished strips.

8.2 *Final Preparation*—For strips prepared in 8.1 or new strips being used for the first time, remove a strip from its protected location, such as by removing it from the wash solvent. To prevent possible surface contamination during final preparation, do not allow fingers to come in direct contact with the copper strips, such as by wearing disposable gloves or holding the strips in the fingers protected with ashless filter paper. Polish first the ends and then the sides with the 105  $\mu\text{m}$  (120-grit to 150-grit CAMI-grade or P120 to P150 FEPA-grade) silicon carbide grains picked up with a pad of absorbent cotton moistened with wash solvent. Wipe vigorously with fresh pads of absorbent cotton and subsequently handle without touching the surface of the strip with the fingers. Padded forceps (to prevent the scratching of the surface) have been found suitable to use. Secure the copper strip in a vise or suitable holder and polish the main surfaces with silicon-carbide grains on absorbent cotton. Do not polish in a circular motion. Rub in the direction of the long axis of the strip, carrying the stroke beyond the end of the strip before reversing the direction. Clean all metal dust from the strip by rubbing vigorously with clean pads of absorbent cotton until a fresh pad remains unsoiled. When the strip is clean, with minimal delay, attach to the dip tube and lower into the prepared corrosion test cylinder (see Fig. 1).

8.2.1 It is important to polish the whole surface of the strip uniformly to obtain a uniformly stained strip. If the edges show wear (surface elliptical) they will likely show more corrosion than the center. The use of a vise will facilitate uniform polishing.

8.2.2 It is important to follow the order of preparation with the correctly sized silicon carbide material as described in 8.1 and 8.2. The final preparation is with 105  $\mu\text{m}$  (120-grit to 150-grit CAMI-grade or P120 to P150 FEPA-grade) silicon carbide grains. This is a larger grain size than the 65  $\mu\text{m}$  grade (220-grit CAMI-grade or P220 FEPA-grade) paper used in the surface preparation stage. The reason for this use of larger silicon carbide grains in the final preparation is to produce asperities (controlled roughness) on the surface of the copper which act as sites for the initiation of corrosion reactions.

## 9. Sampling

9.1 Obtain a sample from a point in the LPG system that will give a representative sample of the volume being tested, such as from a dynamic flowing stream or from a well mixed container, as appropriate. Preferably, collect the sample directly into the corrosion test cylinder (6.1) after it has been prepared for testing (10.1). Pay particular attention to safety and warning notes in Practices D1265 and D3700.

9.2 Alternatively, collect a sample in accordance with Practices D1265 and D3700.

9.2.1 If a sample is first collected in a sampling cylinder, ensure that the interior surfaces are inert and will not react with corrosive species. Sampling cylinders with protective (inert) internal coatings or surface treatments (such as fused glass) may be used.

NOTE 2—Some internal coatings are porous and can adsorb or release contaminants that can affect test results. Also, fresh steel surfaces can react with some corrosive sulfur species and potentially remove them, which could result in a “false pass” in the copper strip corrosion test.

9.3 Flushing a prepared (wetted) test cylinder with LPG as is the practice at a flowthrough sampling station can invalidate the test by drying the cylinder walls. While a flow-through sampling station can help ensure that a representative sample is collected, care shall be taken that the procedure for collecting a sample for this test method is followed to remove air but not flow liquid LPG through the cylinder excessively which could dry the wetted surfaces (10.3).

9.4 The time between when the sample is collected and when the test is begun should be held to a minimum (preferably only a few minutes) (see Note 3).

9.5 In case of dispute, a sample shall be collected directly into a corrosion test cylinder.

## 10. Procedure

10.1 With Valve B (Fig. 1), open, place approximately 1 mL of distilled water into a clean test cylinder and swirl to moisten the walls; allow the remainder to drain from the cylinder, insert the freshly polished copper strip suspended from the hook on the dip tube making sure that the bottom of the strip is at least 6.4 mm ( $\frac{1}{4}$  in.) from the bottom of the cylinder when assembled. After assembly of the apparatus, close both Valve A (Fig. 1), on closure assembly with outage tube, and Valve B.

10.2 Prior to collecting a test sample, air shall be purged from the test cylinder with the sample to be measured in a manner that does not dry the cylinder walls.

10.2.1 *Procedure A:*

10.2.1.1 Holding the test cylinder upright so as not to wet the copper strip with water, attach the sample source to the test cylinder Valve A (Fig. 1) by means of a short length of flexible inert hose that has been purged with the sample. Admit some sample to the cylinder by opening the valve at the sample source and then Valve A.

10.2.1.2 Close Valve A without disconnecting the test cylinder from the sample source. Invert the test cylinder and open Valve B to purge the air from the test cylinder. Return the test cylinder to the upright position and drain any residual liquid through the open Valve B. Close Valve B. Continue to 10.3.

10.2.2 *Procedure B:*

10.2.2.1 Holding the test cylinder upright so as not to wet the copper strip with water, attach the reagent grade LPG to the test cylinder Valve A (Fig. 1) by means of a short length of flexible inert hose that has been purged with the reagent grade LPG. Admit some reagent grade LPG to the cylinder by opening the valve at the sample source and then Valve A.

10.2.2.2 Close Valve A without disconnecting the test cylinder from the reagent grade LPG. Invert the test cylinder and open Valve B to purge the air from the test cylinder. Return the test cylinder to the upright position and drain any residual liquid through the open Valve B. Close Valve B. Disconnect the reagent grade LPG.

10.2.2.3 Attach the sample source to the test cylinder Valve A (Fig. 1) by means of a short length of flexible inert hose that has been purged with the sample. Continue to 10.3.

10.3 Hold the test cylinder in its upright position while sampling. With Valve B closed, open Valve A and fill the test cylinder with the sample. When the test cylinder is full, close Valve A, the valve at the sample source, and disconnect the tubing.

10.3.1 (**Warning**—Provide a safe means for the disposal of vapors and liquids during this and subsequent procedures.)

10.4 As soon as the flexible inert hose is disconnected, and with the cylinder in its upright position, open Valve A slightly so that all liquid above the end of the outage tube will be removed from the test cylinder. When vapor first emerges from Valve A, close Valve A.

10.5 With minimal delay, and as soon as practical after filling and venting (described in 10.4) the test cylinder (see Note 3), immerse the test cylinder in the water bath maintained at  $37.8\text{ °C} \pm 0.5\text{ °C}$  ( $100\text{ °F} \pm 1\text{ °F}$ ). Allow the test cylinder to remain in the bath for  $1\text{ h} \pm 5\text{ min}$ .

NOTE 3—Any delay between preparing the test cylinder, collecting the sample, and immersing the test cylinder in the water bath gives the copper strip more time in the sample, and thus more time to potentially develop increased discoloration if corrosive species are present in the sample.

10.6 At the end of the test period remove the cylinder from the bath and, holding the cylinder in a vertical position, open the bottom valve to a suitable disposal unit (10.3.1) until all of the liquid and most of the vapor is discharged.

10.7 When only a slight pressure remains in the cylinder, disassemble immediately and compare at once the copper strip that has been exposed to the liquefied petroleum gases with the ASTM Copper Strip Corrosion Standard (ADJD0130).

10.8 Handling only with stainless steel forceps, compare the exposed strip with the ASTM Copper Strip Corrosion Standard (ADJD0130). See Section 11 for further guidance and clarification. Hold both the test strip and the standard in such a manner that light reflected from them at an angle of approximately  $45^\circ$  will be observed. In handling the test strip during the inspection and comparison, the danger of marking or staining can be avoided if it is inserted in a flat test tube which is then stoppered with absorbent cotton.

10.9 If the copper strip contacts the water-moistened walls of the cylinder, or water droplets are splashed onto the copper strip