



Designation: ~~F526--16~~ F526 – 21

Standard Test Method for Using Calorimeters for Total Dose Measurements in Pulsed Linear Accelerator or Flash X-ray Machines¹

This standard is issued under the fixed designation F526; the number immediately following the designation indicates the year of original adoption or, in the case of revision, the year of last revision. A number in parentheses indicates the year of last reapproval. A superscript epsilon (ϵ) indicates an editorial change since the last revision or reapproval.

This standard has been approved for use by agencies of the U.S. Department of Defense.

1. Scope

1.1 This test method covers a calorimetric measurement of the total absorbed dose delivered ~~in~~by a single pulse of electrons from an electron linear accelerator or a flash X-ray machine (FXR, e-beam ~~mode~~) ~~used as an ionizing source in radiation effects testing mode~~. The test method is designed for use with pulses of electrons in the energy range from 10 to 50 MeV and is only valid for cases in which both the calorimeter and the test specimen to be irradiated are “thin” compared to the range of these electrons in the materials of which they are constructed.

1.2 The procedure described can be used in those cases in which (1) the dose delivered in a single pulse is 5 Gy(matl)^2 [500 rd (matl)] or greater, or (2) multiple pulses of a lower dose can be delivered in a short time compared to the thermal time constant of the calorimeter. The units for the total absorbed dose delivered to a material require the specification of the material and the notation “matl” refers to the active material of the calorimeter. The minimum dose per pulse that can be acceptably monitored depends on the variables of the particular test, including pulse rate, pulse uniformity, and the thermal time constant of the calorimeter.

<https://standards.iteh.ai/catalog/standards/sist/1849cce5-e584-4abd-9cf7-cb4a138a37b6/astm-f526-21>

1.3 A determination of the total dose is made directly for the material of which the calorimeter block is made. The total dose in other materials can be calculated from this measured value ~~by formulas using Eq 3~~ presented in this test method. The need for such calculations and the choice of materials for which calculations are to be made shall be subject to agreement by the parties to the test.

1.4 The values stated in SI units are to be regarded as the standard. The values in parenthesis are provided for information only.

1.5 *This standard does not purport to address all of the safety concerns, if any, associated with its use. It is the responsibility of the user of this standard to establish appropriate ~~safety~~ safety, health, and ~~health~~ environmental practices and determine the applicability of regulatory limitations prior to use.*

1.6 *This international standard was developed in accordance with internationally recognized principles on standardization established in the Decision on Principles for the Development of International Standards, Guides and Recommendations issued by the World Trade Organization Technical Barriers to Trade (TBT) Committee.*

¹ This test method is under the jurisdiction of ASTM Committee E10 on Nuclear Technology and Applications and is the direct responsibility of Subcommittee E10.07 on Radiation Dosimetry for Radiation Effects on Materials and Devices.

Current edition approved June 1, 2016 June 1, 2021. Published July 2016 July 2021. Originally published as F526 – 77 T. Last previous edition approved in 2014 2016 as F526 – 11, F526 – 16. DOI: 10.1520/F0526-16.10.1520/F0526-21.

² In 1975 the General Conference on Weights and Measures adopted the unit gray (~~symbol – Gy~~) (~~symbol – Gy~~) for absorbed dose; 1 Gy = 100 ~~rad~~ rd.

2. Referenced Documents

2.1 ASTM Standards:³

[E170 Terminology Relating to Radiation Measurements and Dosimetry](#)

[E230 Specification for Temperature-Electromotive Force \(emf\) Tables for Standardized Thermocouples](#)

[E1894 Guide for Selecting Dosimetry Systems for Application in Pulsed X-Ray Sources](#)

3. Terminology

3.1 Definitions:

3.1.1 *device under test (DUT)*—the device that is ~~under the current test~~being tested.

3.1.2 *Seebeck EMF*—the electromagnetic force (EMF) generated by the Seebeck effect when two wires composed of dissimilar metals are joined at both ends and the ends are held at different temperatures. A voltage can be measured across the terminals when current flows through the wires.

3.1.3 *temperature coefficient of resistance*—the resistance change in a material per degree of temperature change $d\Omega/(\Omega \cdot d\theta)$, where Ω denotes the resistance and θ denotes the temperature. This quantity has units of inverse temperature and, for small changes about a reference temperature in a conductor, this quantity is often modeled as a linear relationship with temperature.

3.1.4 *thermal time constant of a calorimeter*—the time for the temperature excursion of the calorimeter material resulting from a radiation pulse to drop to $1/e$ of its initial maximum value.

3.1.5 *TSP*—twisted shielded pair, a shielded case of a twisted pair cable in which two conductors are twisted together for the purpose of canceling out electromagnetic interference from external sources.

3.2 Definitions of other terms used in this standard that pertain to radiation measurements and dosimetry may be found in Terminology [E170](#).

4. Summary of Test Method

4.1 *Single-Pulse Method*—This method consists of (1) irradiating, with a single pulse of high-energy electrons from an electron linear accelerator (linac) or flash X-ray machine (FXR), a small block of material to which either a thermistor or a thermocouple made from small-diameter wire is attached; (2) recording and measuring the resulting signal from a bridge circuit or directly from the thermocouple; (3) calculating the total dose deposited in the block based on the temperature rise and the specific heat of the material; and (4) if required, calculating the equivalent dose in other specified materials exposed to this same pulse.

4.2 *Multiple-Pulse Method*—If the dose available in a single pulse is not large enough to give measurable results, the linac is pulsed repeatedly within a time short compared to the thermal time constant of the calorimeter. This method is similar to the single-pulse method except that the average dose delivered in each pulse is calculated from the measured cumulative dose of all the pulses.

5. Significance and Use

5.1 An accurate measure of the total absorbed dose is necessary to ensure the validity of the data taken, to enable comparison to be made of data taken at different facilities, and to verify that components or circuits are tested to the radiation specification applied to the system for which they are to be used.

5.2 The primary value of a calorimetric method for measuring dose is that the results are absolute. They are based only on physical properties of materials, that is, the specific heat of the calorimeter-block material and the Seebeck EMF of the thermocouple used or the temperature coefficient of resistance (α) of the thermistor used, all of which can be established with non-radiation measurements.

³ For referenced ASTM standards, visit the ASTM website, www.astm.org, or contact ASTM Customer Service at service@astm.org. For *Annual Book of ASTM Standards* volume information, refer to the standard's Document Summary page on the ASTM website.

5.3 The method permits repeated measurements to be made without requiring entry into the radiation cell between measurements.

6. Interferences

6.1 *Thermal Isolation*—If the thermal isolation of the calorimeter is not sufficient, the thermal time constant of the calorimeter response will be too short for it to be useful.

NOTE 1—This condition can be caused by insufficient insulation material or by heat loss through the thermocouple wires themselves.

6.2 *Thermal Equilibrium*—The initial value of the transient temperature change following a radiation pulse may not reflect the true temperature change of the calorimeter-block material.

NOTE 2—This situation can be brought about by a temperature rise occurring in the materials at the point of attachment of the thermocouple or the thermistor different from that in the calorimeter-block material. As long as the calorimeter block comprises the great bulk of the calorimeter material, the temperature will quickly equilibrate to that of the block, and the subsequent temperature record will be that of the calorimeter-block material (see [Appendix X1](#)).

6.3 *Pulse Reproducibility*—If pulse-to-pulse reproducibility of the radiation source varies more than $\pm 20\%$, a good measure of the dose per pulse may not be attainable from the average value calculated in the multiple-pulse method.

6.4 *Facility Spot Size*—If the calorimeter is used in high-dose rate positions, the spot size (especially in ebeam facilities) may not be large enough to adequately cover the calorimeter material.

7. Apparatus

7.1 *Pulsed Electron Source:*

7.1.1 *Linac*—Electron linear accelerator and associated instrumentation and controls suitable for use as an ionizing source infor radiation-effects testing. See Guide [E1894](#).

7.1.2 *FXR*—Flash X-ray system that provides intense bremsstrahlung X-ray radiation environments, usually in a single sub-microsecond pulse, and which can often fluctuate in amplitude, shape, and spectrum from shot to shot. This system can be operated in an electron beam mode by not utilizing the bremsstrahlung converter. See Guide [E1894](#).

7.2 *Calorimeter*—Special instrument suitable for measuring the total dose delivered by the linac and constructed in accordance with any of several designs utilizing any indicated in [Appendix X1](#) of several materials as indicated in [Appendix X1](#). A selection of calorimeter materials [Appendix X1](#) and their properties are shown in [Table 1](#). Although measurement differences resulting from the use of different designs should not be significant, all parties to the test shall agree to a single design utilizing a single calorimeter-block material and a specific thermocouple or thermistor (see [Fig. 1](#)). The calorimeter design shall be such that the surface

TABLE 1 Physical Properties of Some Calorimeter-Block Materials

Material	Energy Loss ^A dE/dx (10 ⁻¹⁴ J·m ² /kg)	Specific Heat, c _p ^B (J/kg·K)	Density, ρ ^B (10 ³ kg/m ³)
C	2.92	711	2.10
Al	2.74	900	2.70
Si	2.84	711	2.33
Fe	2.52	452	7.87
Cu	2.42	385	8.96
Ge	2.45	322	5.32
W	2.08	134	19.3
Au	2.06	130	19.3
Pb	2.07	128	11.4

^A The data are given for 20-MeV electrons, but ratios based on these values are good to better than 2 % over the energy range from 10 to 50 MeV, inclusive. These values have been converted to SI units from data given in Refs [\(31\)](#) and [\(52\)](#).

^B These values have been converted to SI units from data given in the Ref [\(63\)](#). (The specific heat values are applicable in the range from 18 to 30°C, inclusive.)

density in the material surrounding the active calorimeter material that is penetrated along the beam path is less than or equal to no more than 20 % of the range of the beam-energy electrons (see electrons, Fig. 1):

7.3 D-C Low Noise Amplifier (LNA), with a gain of 1000 to 10 000 (see Fig. 2).

NOTE 3—An analog nanovoltmeter with a recorder output can also be used as a low noise amplifier. These devices produce a 1-V output for a full scale reading.

7.3.1 Response time less than 0.1 s for the amplifier output to reach 90 % of its final reading,

7.3.2 Noise level less than 10 mV rms referred to the output,

7.3.3 Measurement accuracy of 2 % of full scale or better,

7.3.4 Normal-mode rejection capability such that AC voltages of 50 Hz and above and 60 dB greater than the range setting shall not affect the instrument reading by less than 2 %.

NOTE 4—If the meter does not have an internal nulling circuit, it may be necessary to use a simple bucking circuit to null out thermal EMFs in the measuring circuit to keep the meter on scale at the high-gain positions used in this measurement (see Fig. 1).

7.4 Data Recorder—Linear-response recorder or digital oscilloscope meeting the following specifications:

7.4.1 Recording duration sufficient to capture 5 to 10 s of calorimeter response.

7.4.2 The recording frequency shall be chosen to sufficiently capture the measurement signal.

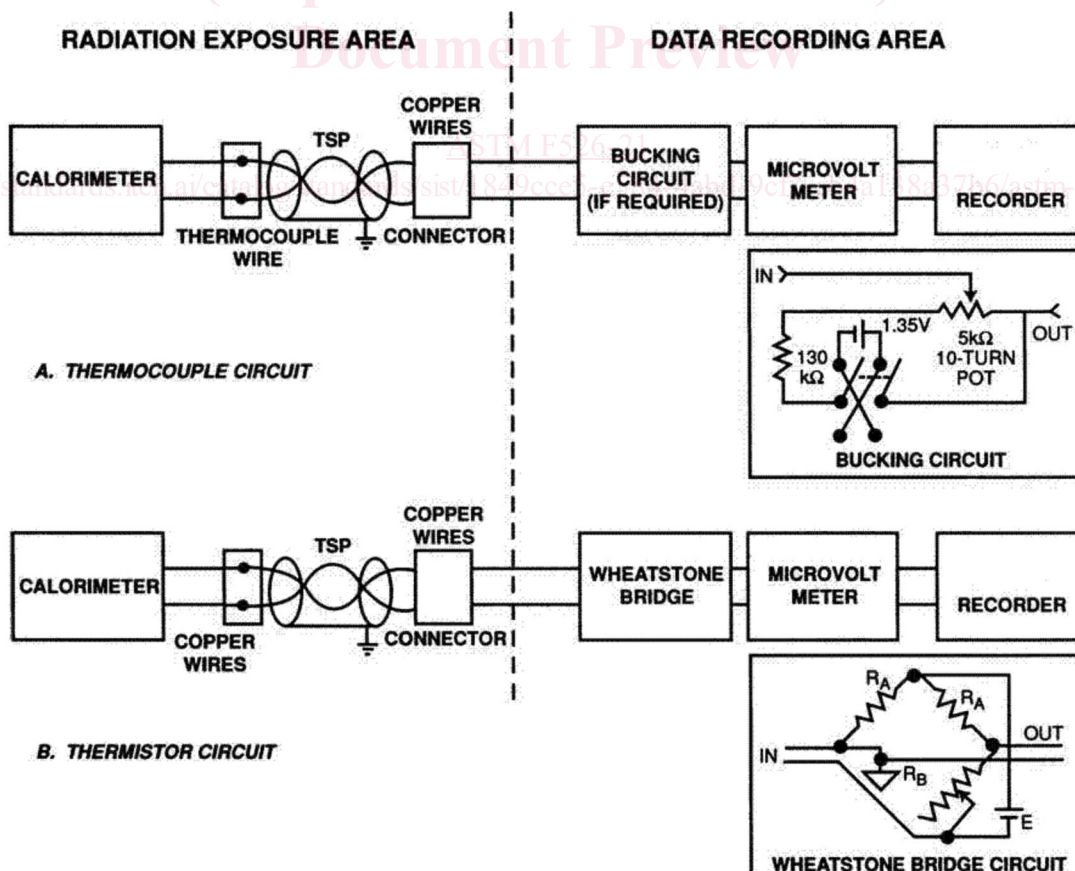
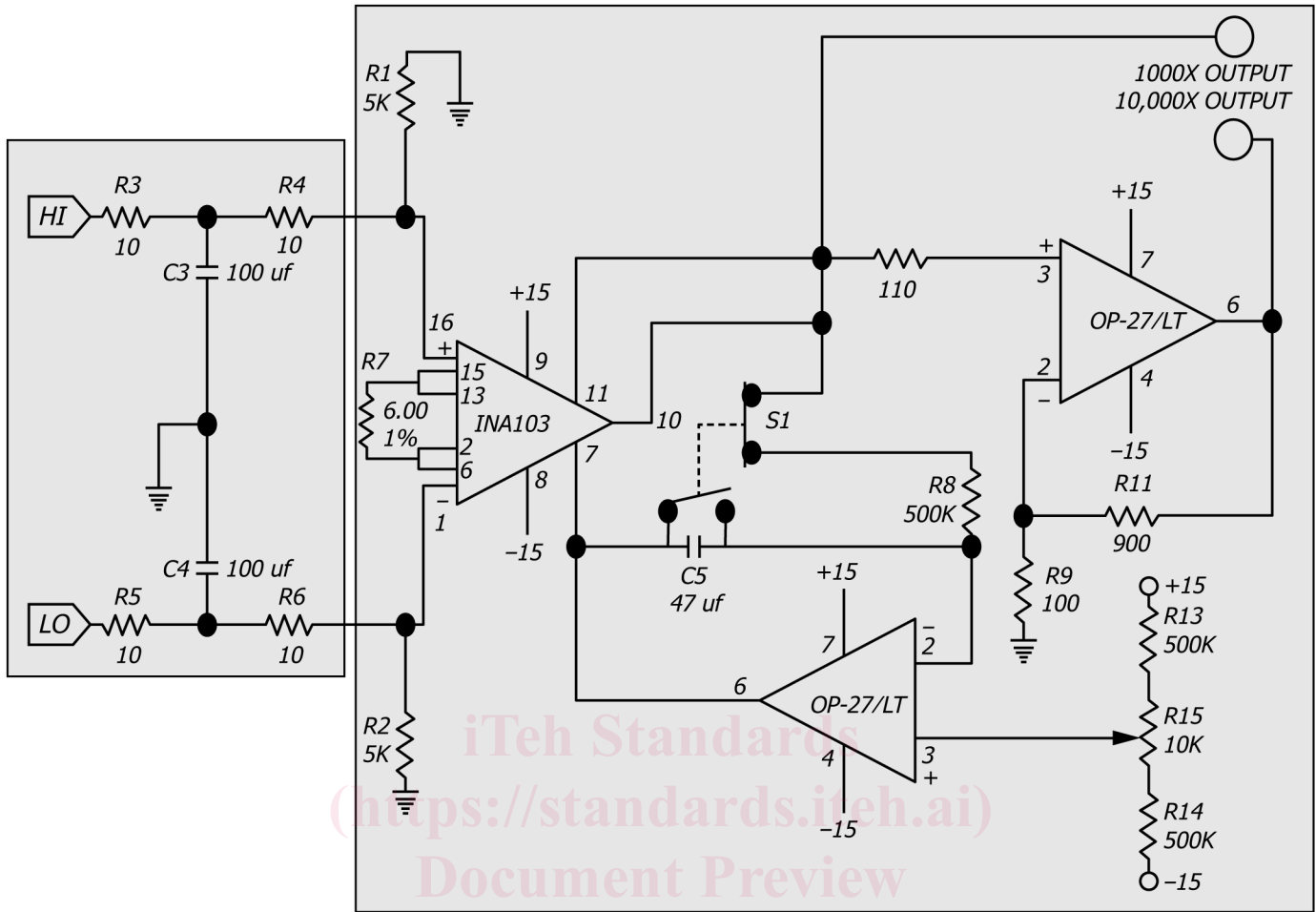

FIG. 1 Typical Block Diagram of Calorimeter Dosimeter Circuit



S1 for Auto Zero

FIG. 2 Recommended Low Noise Amplifier Schematic Diagram

<https://standards.iteh.ai/catalog/standards/sist/1849cce5-e584-4abd-9cf7-cb4a138a37b6/astm-f526-21>

7.5 Voltage Calibration Source—Voltage source capable of meeting the following specifications:

- 7.5.1 Output voltages including 1.5, 3.0, 5.0, 10.0, 15, 30, 50, and 100 μ V,
- 7.5.2 Accuracy of $\pm 1\%$ of the selected voltage, or better,
- 7.5.3 Thermally generated voltages of less than 100 nV with the source stabilized, and
- 7.5.4 Source resistance of 100 Ω or less.

7.6 Wheatstone Bridge Circuit, designed so that the thermistor forms one leg of the bridge, and so that the adjustable resistor of the bridge will be equal to the resistance of the thermistor at balance (see Fig. 1B).

7.7 Flash X-ray Machine (E-beam Mode)—An FXR operated in the e-beam mode generally provides a higher dose rate than similar machines operated in photon, for example, bremsstrahlung, mode. However, testing in the e-beam mode requires that appropriate precautions be taken and special test fixtures be used to ensure meaningful results. The beam produces a large magnetic field, which may interfere with the instrumentation, and can induce large circulating currents in device leads and metals. The beam also produces air ionization, induced charge on open leads, and unwanted cable currents and voltages. E-beam testing is generally performed with the device-under-test (DUT) mounted in a vacuum to reduce air ionization effects. Some necessary precautions are:

- 7.7.1 The electron beam must be constrained to the region that is to be irradiated. Support circuits and components must be properly shielded.

7.7.2 The total electron beam ~~must current shall be stopped~~ absorbed within the test chamber and returned to the FXR to prevent unwanted currents in cables and secondary radiation in the exposure room.

7.7.3 All cables and wires must be protected shielded from exposure to prevent ~~extraneous currents. These currents unwanted signal noise.~~ Noise may be caused by direct deposition of the beam in cables, or by magnetic coupling of the beams into the cable.

7.7.4 An evacuated chamber for the test is required to reduce the effects of air ionization.

8. Sampling

8.1 The number of measurements shall be subject to agreement by the parties to the test. Care should be taken to select a sample size that will produce an acceptable uncertainty.

9. Calibration

9.1 The LNA and recorder should be calibrated to be within $\pm 2\%$ of full scale.

10. Procedure

10.1 *Single-Pulse Method:*

10.1.1 Position the calorimeter at the location where the dose measurement is desired.

10.1.2 Connect all components of the calorimetric dosimeter system in accordance with the circuit shown in **Fig. 1**.

10.1.3 Set the LNA for a gain of 10 000 (or 1000, if using the thermistor circuit).

NOTE 5—A LNA is not always needed if the calorimeter is used at high dose positions. The signal for some calorimeter materials can be quite large.

10.1.4 For the thermocouple measurements, adjust either the internal nulling circuit of the LNA or the external bucking circuit so that the meter deflection caused by the quiescent level of the calorimeter output is less than full scale. For thermistor measurements adjust the bridge for a null. Use the zero-adjust capability of the data recorder to position the recorder trace near the center of the recorder chart. If using an oscilloscope, adjust the settings accordingly to make sure that the response if noticeable is fully captured within the oscilloscope window. Refer to the oscilloscope manual to ensure that the proper resolution are is set to capture the response signal.

NOTE 6—With either system, there will likely be a drift as the temperature of the calorimeter equilibrates. This drift is compensated for in data reduction and may be neglected if the rate of change is much less than that caused by the radiation pulse.

10.1.5 If using a data recorder sweep speed set within the range from 0.5 to 2.0 cm/s, inclusive, trigger the recorder and pulse the source.

10.1.6 If the transient deflection of the recorder is less than 10 % of full scale, set the recorder range to the next lower range and repeat **10.1.5**.

NOTE 7—Care should be taken if multiple pulses are going to be administered, because of the temperature that the pulses generate, which will cause the calorimeter to rise. The protocol for establishing the temperature in a multiple irradiation shall be established before the testing is initiated, for example, it should be stated up front if you are going to use the average from a specified number of pulses as being representative of all shots. This protocol should be done two or three times during a shot day. If you want best accuracy, wait for the calorimeter to cool down between pulses and allow the calorimeter signal to use at least half the range.

10.1.7 Repeat **10.1.5** and **10.1.6** until a range is found for which the greater-than-10 % criterion is met, or until there are no more ranges to try.

10.1.7.1 When a range is found for which this greater-than-10 % criterion is met, note the data recorder setting beside the recorded transient with the shot number, date, LNA gain, calorimeter identification, and description of irradiation geometry (including scatterer thickness and distance of the calorimeter from the scatterer) as shown in **Fig. 3** and **Fig. 4**.

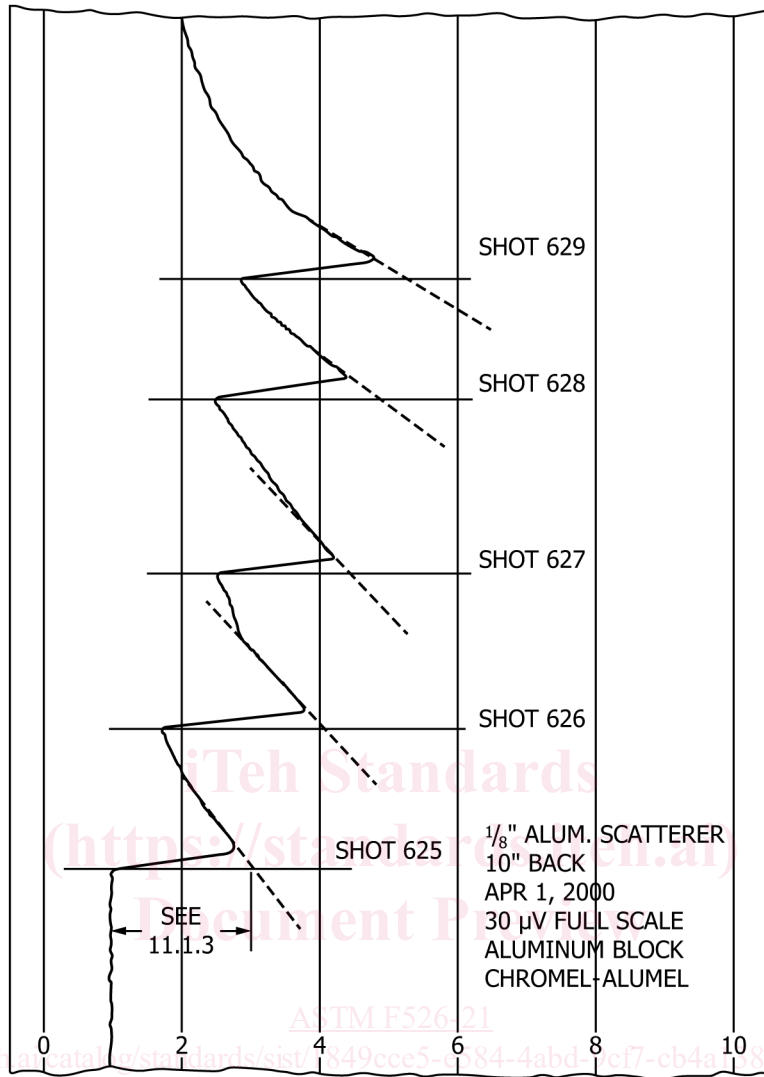

FIG. 3 Typical Chart Record of Calorimeter Dosimetry Using Single-Pulse Method

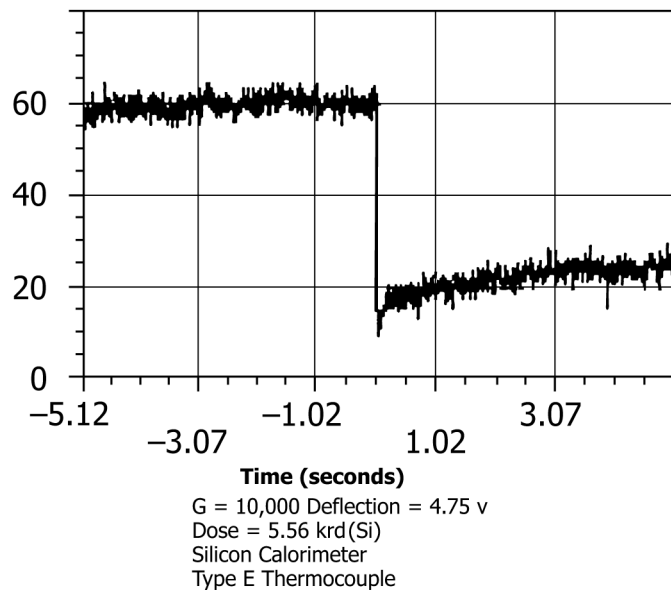

FIG. 4 Typical Digital Oscilloscope Recording of the Calorimeter Response