



Designation: D4475 – 21

Standard Test Method for Apparent Horizontal Shear Strength of Pultruded Reinforced Plastic Rods By the Short-Beam Method¹

This standard is issued under the fixed designation D4475; the number immediately following the designation indicates the year of original adoption or, in the case of revision, the year of last revision. A number in parentheses indicates the year of last reapproval. A superscript epsilon (ϵ) indicates an editorial change since the last revision or reapproval.

1. Scope*

1.1 This test method covers the determination of the apparent horizontal shear strength of fiber reinforced plastic rods. The specimen is a short beam in the form of lengths of pultruded rods. This test method is applicable to all types of parallel-fiber-reinforced plastic rod samples.

1.2 This test method is primarily used for quality control and specification purposes (see 5.1).

1.3 The values stated in SI units are to be regarded as standard.

1.4 *This standard does not purport to address all of the safety concerns, if any, associated with its use. It is the responsibility of the user of this standard to establish appropriate safety, health, and environmental practices and determine the applicability of regulatory limitations prior to use.*

NOTE 1—There is no known ISO equivalent to this standard.

1.5 *This international standard was developed in accordance with internationally recognized principles on standardization established in the Decision on Principles for the Development of International Standards, Guides and Recommendations issued by the World Trade Organization Technical Barriers to Trade (TBT) Committee.*

2. Referenced Documents

2.1 *ASTM Standards:*²

D618 Practice for Conditioning Plastics for Testing

D883 Terminology Relating to Plastics

E4 Practices for Force Verification of Testing Machines

E456 Terminology Relating to Quality and Statistics

E691 Practice for Conducting an Interlaboratory Study to Determine the Precision of a Test Method

¹ This test method is under the jurisdiction of ASTM Committee D20 on Plastics and is the direct responsibility of Subcommittee D20.18 on Reinforced Thermosetting Plastics.

Current edition approved July 1, 2021. Published July 2021. Originally approved in 1985. Last previous edition approved in 2016 as D4475 - 02(2016). DOI: 10.1520/D4475-21.

² For referenced ASTM standards, visit the ASTM website, www.astm.org, or contact ASTM Customer Service at service@astm.org. For *Annual Book of ASTM Standards* volume information, refer to the standard's Document Summary page on the ASTM website.

3. Terminology

3.1 Terms used in this standard are defined in accordance with Terminology D883, unless otherwise specified. For terms relating to precision and bias and associated issues, the terms used in this standard are defined in accordance with Terminology E456.

4. Summary of Test Method

4.1 The horizontal-shear test specimen is center-loaded as shown in Fig. 1. The ends of the specimens rest on two supports that allow the specimen to bend, the load being applied by means of a loading nose at midpoint along the support span, as shown in Fig. 2.

4.2 The specimen is deflected until a shear failure occurs at the midplane of the horizontally supported rod. Adjust the span to achieve the required shear mode of failure.

NOTE 2—Using a span of three times the diameter of rod typically causes shear failure. If needed, that span can be adjusted up to six times the diameter of the rod.

5. Significance and Use

5.1 Apparent shear strength determined by this test method is useful for quality control and specification purposes. It is also applicable to research and development programs concerned with interlaminar-shear strength. The apparent shear strength obtained by this test method is not intended for design purposes, but allowed to be utilized for comparative testing of composite materials, if all failures are in horizontal shear.

5.2 It is recommended that control samples be fabricated with each research test series and that care be used to compare each set of controls with corresponding test series run at different times.

6. Apparatus

6.1 *Testing Machine*—A properly calibrated testing machine that can be operated at a constant rate of crosshead motion, and in which the error in the load measuring system shall not exceed $\pm 1\%$ of the maximum load expected to be measured. The load-indicating mechanism shall be essentially free of inertia lag at the crosshead rate used. The accuracy of the testing machine shall be verified in accordance with Practices E4.

*A Summary of Changes section appears at the end of this standard

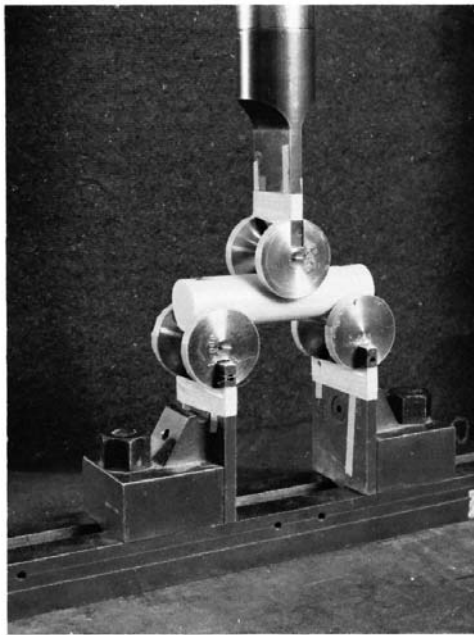

FIG. 1 Test Assembly

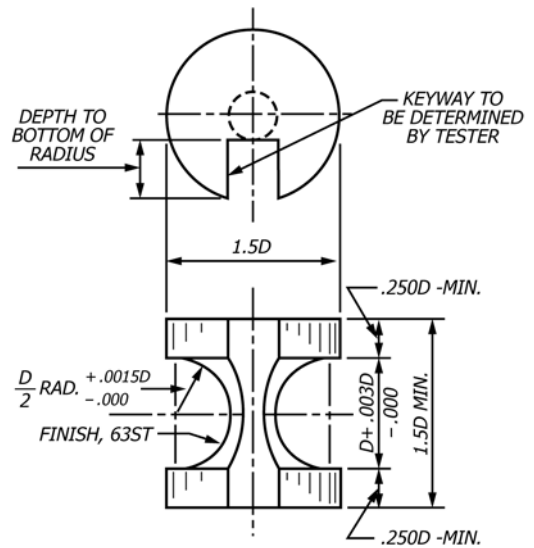

FIG. 3 Anvil Dimensions

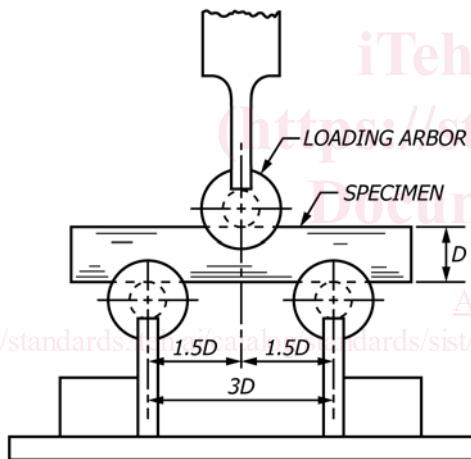

FIG. 2 Span Configuration for a Span of L Units

6.2 *Loading Nose and Supports*—Shown in Fig. 2 and Fig. 3. The loading nose shall be a suitable steel rod with a groove in the diameter of the pultruded rod machined in its lower end. The groove diameter shall always have a plus tolerance and zero negative tolerance. The bottom support shall be adjustable to allow for testing at various span/diameter ratios. The surface of the groove shall be free of indentation and burrs, with all sharp edges relieved.

6.3 *Micrometers*—Suitable micrometers for measuring the diameter of the test specimen to an incremental discrimination of at least 0.025 mm (0.001 in.) shall be used.

7. Test Specimen

7.1 The specimen shall be cut from the pultruded rod to a length of one diameter greater than the test span and to a tolerance of plus or minus 0.1 times the diameter.

7.2 *Number of Specimens*—The number of test specimens is optional. However, a minimum of five specimens is required to obtain a satisfactory average and standard deviation.

8. Conditioning

8.1 *Conditioning*—Condition the test specimens at $23 \pm 2^\circ\text{C}$ ($73.4 \pm 3.6^\circ\text{F}$) and $50 \pm 5\%$ relative humidity for not less than 40 h prior to test, in accordance with Procedure A of Practice D618 for those tests where conditioning is required. In cases of disagreement, the tolerances shall be $\pm 1^\circ\text{C}$ ($\pm 1.8^\circ\text{F}$) and $\pm 2\%$ relative humidity. These conditions are recommended for research and development trials, but not necessarily for quality control. However, temperature control to $22.2 \pm 5.6^\circ\text{C}$ ($72 \pm 10^\circ\text{F}$) is recommended for quality control.

8.2 *Test Conditions*—Conduct tests in the standard laboratory atmosphere of $23 \pm 2^\circ\text{C}$ ($73.4 \pm 3.6^\circ\text{F}$) and $50 \pm 5\%$ relative humidity, unless otherwise specified in the test methods. In cases of disagreement, the tolerances shall be $\pm 1^\circ\text{C}$ ($\pm 1.8^\circ\text{F}$) and $\pm 2\%$ relative humidity.

8.3 Preconditioning in other environments to simulate specified conditions and durations is permissible.

8.4 Testing in other environmental conditions is permissible.

9. Speed of Testing

9.1 Test the specimen at a rate of crosshead motion of 1.3 mm (0.05 in.)/min.

NOTE 3—The test time should be recorded, and, if the test takes less than 20 s, the rate of crosshead motion should be decreased. If the test takes over 200 s, the crosshead rate should be increased gradually, or in steps, until the time to complete the test is less than 200 s.

10. Procedure

10.1 Before conditioning or testing, measure the diameter of each specimen to the nearest 0.025 mm (0.001 in.) at midpoint.

10.2 Place the rod test specimen in the test fixture, as shown in Fig. 1. Align the specimen so that its midpoint is centered and its long axis is perpendicular to the loading nose. Adjust the side supports to the span previously determined. Suggested span-to-diameter ratios are from 3 to 1 up to 6 to 1. The obtainment of shear fractures during the test is a major consideration in determining span length.

NOTE 4—Experimental data indicates that shear strength is a function of support span-to-specimen diameter ratio in most materials. When writing specifications, both the specimen diameter and the span-to-diameter ratio should be specified.

10.3 Apply the load to the specimen at the specified crosshead rate. Record the load to break for each specimen (maximum load on load-indicating mechanism). At times, when testing pultruded rods in various environments, specimens do not consistently fail in shear, especially when the incorrect span-to-depth ratio is chosen. It is, therefore, very important to record the type of break (shear or tensile) that occurs. For research purposes, it is also useful to record the position of the shear plane relative to the specimen center line.

11. Retest

11.1 Values for properties at break shall not be calculated for any specimen that breaks at some obvious, fortuitous flaw, unless such flaws constitute a variable being studied. Retests shall be made for any specimen on which values are not calculated. Specimens failed in a manner other than horizontal shear, the value shall be discarded, and a retest shall be made. However, some of the specimens may not show a distinct failure mode, particularly after preconditioning. It is suggested that some form of chart movement, such as chart speed or a deflectometer, be used to help determine the fracture point. This is normally the first major load reduction or sudden change in slope of the load-deflection curve.

TABLE 1 Precision Data for Shear Strength

		Shear Strength, 10 ³ psi				
		Room Temperature				
		Values in the units of psi				
Material	Rod Diameter	Mean	S _r ^A	S _R ^B	I _r ^C	I _R ^D
Vinyl ester	0.85 in.	10.2	0.236	0.519	0.665	1.47
Vinyl ester	1.00 in.	9.14	0.161	0.374	0.456	1.06
Polyester	1.20 in.	8.23	0.182	0.854	0.515	2.42
150°F						
Vinyl ester	0.85 in.	7.70	0.245	0.548	0.693	1.55
Vinyl ester	1.00 in.	7.14	0.165	0.415	0.467	1.17
Polyester	1.20 in.	6.83	0.111	0.412	0.314	1.17

^A S_r = within laboratory standard deviation for the indicated material. It is obtained by pooling the within-laboratory standard deviations of the test results for all of the participating laboratories:

$$S_r = [[(S_1)^2 + (S_2)^2 \dots + (S_n)^2] / n]^{1/2}$$

^B S_R = between-laboratories reproducibility, expressed as standard deviation:

$$S_R = [S_r^2 + S_L^2]^{1/2}$$

where S_L = standard deviation of laboratory means.

^C r = within-laboratory critical interval between tow test results = 2.8 × S_r.

^D R = between-laboratories critical interval between tow test results = 2.8 × S_R.

12. Calculations

12.1 Calculate the apparent shear strength as follows:

$$S = 0.849 P/d^2 \tag{1}$$

where:

- S = apparent shear strength, N/m², (or psi),
- P = breaking load, N, (or lbf), and
- d = diameter of specimen, m, (or in.).

12.2 *Arithmetic Mean for Each Series of Tests*—Calculate the arithmetic mean of all values obtained to three significant figures and report as the “average value.”

12.3 *Standard Deviation*—Calculate the standard deviation (estimated) as follows and report to two significant figures:

$$s = \sqrt{(\sum X^2 - n \bar{X}^2) / (n - 1)} \tag{2}$$

where:

- s = estimated standard deviation,
- X = value of a single observation,
- n = number of observations, and
- \bar{X} = arithmetic mean of the set of observations.

13. Report

13.1 The report shall include the following:

- 13.1.1 Complete identification of the material tested, including type, source, form, principle dimensions, and previous history,
- 13.1.2 Fabrication procedure,
- 13.1.3 Diameter of specimen,
- 13.1.4 Conditioning procedure used,
- 13.1.5 Atmospheric conditions in the test room,
- 13.1.6 Number of specimens tested,
- 13.1.7 Rate of crosshead motion,
- 13.1.8 Span length,
- 13.1.9 Length of specimens,
- 13.1.10 Type of failure,
- 13.1.11 Apparent horizontal shear strength of each specimen, average value, and standard deviation,
- 13.1.12 Location of failure, or method of determining failure from curve,
- 13.1.13 Average fiber content, percent by weight, and
- 13.1.14 Date of test.

14. Precision and Bias³

14.1 **Table 1** is based on a round robin conducted in 1984 in accordance with Practice **E691**, involving three materials tested by eleven laboratories. For each material, all the samples were prepared at one source, but the individual specimens were prepared at the laboratories which tested them. Each test result was the average of five individual determinations. Each laboratory obtained two test results for each material. Tests were conducted at room temperature and 150°F.

14.2 *Warning*—The data in **Table 1** shall not be rigorously applied to acceptance or rejection of material, as those data are specific to the interlaboratory study and are not necessarily

³ Supporting data are available at ASTM Headquarters. Request RR:D20-1118.