



Designation: C623 – 21

Standard Test Method for Young's Modulus, Shear Modulus, and Poisson's Ratio for Glass and Glass-Ceramics by Resonance¹

This standard is issued under the fixed designation C623; the number immediately following the designation indicates the year of original adoption or, in the case of revision, the year of last revision. A number in parentheses indicates the year of last reapproval. A superscript epsilon (ϵ) indicates an editorial change since the last revision or reapproval.

1. Scope

1.1 This test method covers the determination of the elastic properties of glass and glass-ceramic materials. Specimens of these materials possess specific mechanical resonance frequencies which are defined by the elastic moduli, density, and geometry of the test specimen. Therefore the elastic properties of a material can be computed if the geometry, density, and mechanical resonance frequencies of a suitable test specimen of that material can be measured. Young's modulus is determined using the resonance frequency in the flexural mode of vibration. The shear modulus, or modulus of rigidity, is found using torsional resonance vibrations. Young's modulus and shear modulus are used to compute Poisson's ratio, the factor of lateral contraction.

1.2 All glass and glass-ceramic materials that are elastic, homogeneous, and isotropic may be tested by this test method.² The test method is not satisfactory for specimens that have cracks or voids that represent inhomogeneities in the material; neither is it satisfactory when these materials cannot be prepared in a suitable geometry. Non-glass and glass-ceramic materials should reference Test Method E1875 for non-material specific methodology to determine resonance frequencies and elastic properties by sonic resonance.

NOTE 1—Elastic here means that an application of stress within the elastic limit of that material making up the body being stressed will cause an instantaneous and uniform deformation, which will cease upon removal of the stress, with the body returning instantly to its original size and shape without an energy loss. Glass and glass-ceramic materials conform to this definition well enough that this test is meaningful.

NOTE 2—Isotropic means that the elastic properties are the same in all directions in the material. Glass is isotropic and glass-ceramics are usually so on a macroscopic scale, because of random distribution and orientation of crystallites.

¹ This test method is under the jurisdiction of ASTM Committee C14 on Glass and Glass Products and is the direct responsibility of Subcommittee C14.04 on Physical and Mechanical Properties.

Current edition approved June 1, 2021. Published July 2021. Originally approved in 1969. Last previous edition approved in 2015 as C623 – 92 (2015). DOI: 10.1520/C0623-21.

² Spinner, S. and Tefft, W. E., "A Method for Determining Mechanical Resonance Frequencies and for Calculating Elastic Moduli From These Frequencies," *Proceedings*, ASTM International, 1961, pp. 1221–1238.

1.3 A cryogenic cabinet and high-temperature furnace are described for measuring the elastic moduli as a function of temperature from –195 to 1200 °C.

1.4 Modification of the test for use in quality control is possible. A range of acceptable resonance frequencies is determined for a piece with a particular geometry and density. Any specimen with a frequency response falling outside this frequency range is rejected. The actual modulus of each piece need not be determined as long as the limits of the selected frequency range are known to include the resonance frequency that the piece must possess if its geometry and density are within specified tolerances.

1.5 The values stated in SI units are to be regarded as standard. No other units of measurement are included in this standard.

1.6 *This standard does not purport to address all of the safety concerns, if any, associated with its use. It is the responsibility of the user of this standard to establish appropriate safety, health, and environmental practices and determine the applicability of regulatory limitations prior to use.*

1.7 *This international standard was developed in accordance with internationally recognized principles on standardization established in the Decision on Principles for the Development of International Standards, Guides and Recommendations issued by the World Trade Organization Technical Barriers to Trade (TBT) Committee.*

2. Referenced Documents

2.1 Reference to these documents shall be the latest issue unless otherwise specified by the authority applying this test method.

2.2 *ASTM Standards:*³

E1875 Test Method for Dynamic Young's Modulus, Shear Modulus, and Poisson's Ratio by Sonic Resonance

3. Summary of Test Method

3.1 This test method measures the resonance frequencies of test bars of suitable geometry by exciting them at continuously

³ For referenced ASTM standards, visit the ASTM website, www.astm.org, or contact ASTM Customer Service at service@astm.org. For *Annual Book of ASTM Standards* volume information, refer to the standard's Document Summary page on the ASTM website.

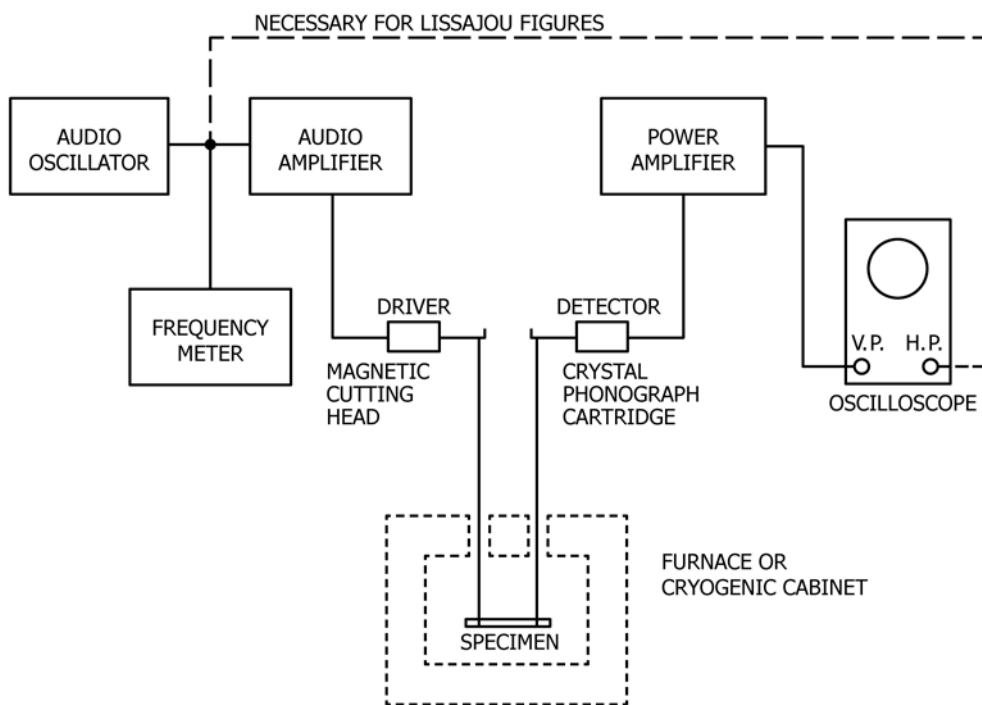

FIG. 1 Block Diagram of Apparatus

variable frequencies. Mechanical excitation of the specimen is provided through use of a transducer that transforms an initial electrical signal into a mechanical vibration. Another transducer senses the resulting mechanical vibrations of the specimen and transforms them into an electrical signal that can be displayed on the screen of an oscilloscope to detect resonance. The resonance frequencies, dimensions, and mass of the specimen are used to calculate Young's modulus and the shear modulus.

4. Significance and Use

4.1 This test system has advantages in certain respects over the use of static loading systems in the measurement of glass and glass-ceramics:

4.1.1 Only minute stresses are applied to the specimen, thus minimizing the possibility of fracture.

4.1.2 The period of time during which stress is applied and removed is of the order of hundreds of microseconds, making it feasible to perform measurements at temperatures where delayed elastic and creep effects proceed on a much-shortened time scale, as in the transformation range of glass, for instance.

4.2 The test is suitable for detecting whether a material meets specifications, if cognizance is given to one important fact: glass and glass-ceramic materials are sensitive to thermal history. Therefore the thermal history of a test specimen must be known before the moduli can be considered in terms of specified values. Material specifications should include a specific thermal treatment for all test specimens.

5. Apparatus

5.1 The test apparatus is shown in Fig. 1. It consists of a variable-frequency audio oscillator, used to generate a sinusoidal voltage, and a power amplifier and suitable transducer to

convert the electrical signal to a mechanical driving vibration. A frequency meter monitors the audio oscillator output to provide an accurate frequency determination. A suitable suspension-coupling system cradles the test specimen, and another transducer acts to detect mechanical resonance in the specimen and to convert it into an electrical signal which is passed through an amplifier and displayed on the vertical plates of an oscilloscope. If a Lissajous figure is desired, the output of the oscillator is also coupled to the horizontal plates of the oscilloscope. If temperature-dependent data are desired, a suitable furnace or cryogenic chamber is used. Details of the equipment are as follows:

5.2 *Audio Oscillator*, having a continuously variable frequency output from about 100 Hz to at least 20 kHz. Frequency drift shall not exceed 1 Hz/min for any given setting.

5.3 *Audio Amplifier*, having a power output sufficient to ensure that the type of transducer used can excite any specimen the mass of which falls within a specified range.

5.4 *Transducers*—Two are required: one used as a driver may be a speaker of the tweeter type or a magnetic cutting head or other similar device, depending on the type of coupling chosen for use between the transducer and the specimen. The other transducer, used as a detector, may be a crystal or magnetic reluctance type of phonograph cartridge. A capacitive pickup may be used if desired. The frequency response of the transducer shall be as good as possible with at least a 6.5 kHz bandwidth before 3-dB power loss occurs.

5.5 *Power Amplifier*, in the detector circuit shall be impedance matched with the type of detector transducer selected and shall serve as a prescope amplifier.

5.6 *Oscilloscope*, shall be any model suitable for general laboratory work.

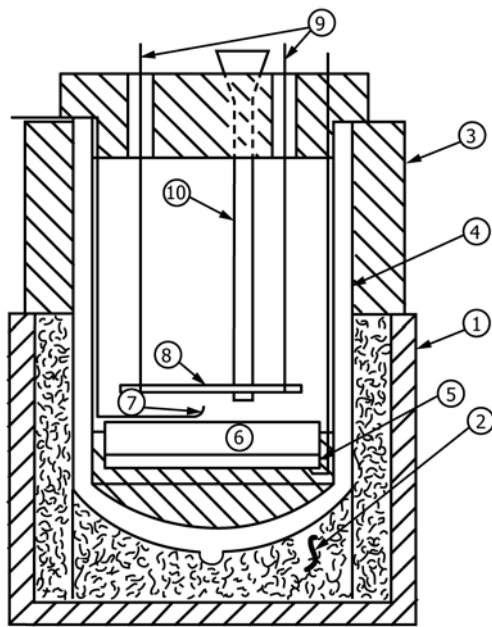

- 1—Cylindrical glass jar
- 2—Glass wool
- 3—Plastic foam
- 4—Vacuum jar
- 5—Heater disk
- 6—Copper plate
- 7—Thermocouple
- 8—Sample
- 9—Suspension wires
- 10—Fill port for liquid

FIG. 2 Detail Drawing of Suitable Cryogenic Chamber

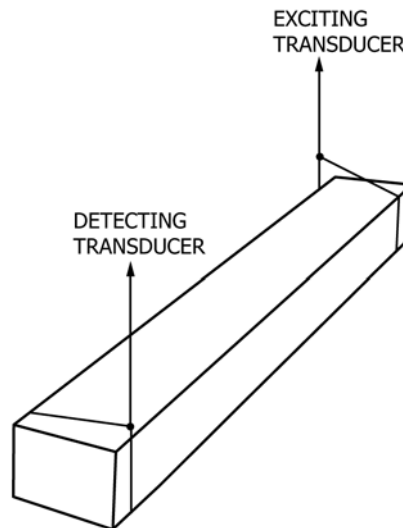

FIG. 3 Specimen Positioned for Measurement of Flexural and Torsional Resonance Frequencies Using Thread or Wire Suspension

6. Test Specimen

6.1 The specimens shall be prepared so that they are either rectangular or circular in cross section. Either geometry can be used to measure both Young's modulus and shear modulus. However, great experimental difficulties in obtaining torsional resonance frequencies for a cylindrical specimen usually preclude its use in determining shear modulus, although the equations for computing shear modulus with a cylindrical specimen are both simpler and more accurate than those used with a prismatic bar.

6.2 Resonance frequencies for a given specimen are functions of the bar dimensions as well as its density and modulus; therefore, dimensions should be selected with this relationship in mind. Selection of size shall be made so that, for an estimated modulus, the resonance frequencies measured will fall within the range of frequency response of the transducers used. Representative values of Young's modulus are 70×10^4 kgf/cm² (69 GPa) for glass and 100×10^4 kgf/cm² (98 GPa) for glass-ceramics. Recommended specimen sizes are 120 by 25 by 3 mm for bars of rectangular cross section, and 120 by 4 mm for those of circular cross section. These specimen sizes should produce a fundamental flexural resonance frequency in the range from 1000 to 2000 Hz. Specimens shall have a minimum mass of 5 g to avoid coupling effects; any size of specimen that has a suitable length-to-cross section ratio in terms of frequency response and meets the mass minimum may be used. Maximum specimen size and mass are determined primarily by the test system's energy and space capabilities.

6.3 Specimens shall be finished using a fine grind, -400-grit or smaller. All surfaces shall be flat and opposite surfaces shall be parallel within 0.02 mm.

7. Procedure

7.1 *Procedure A—Room Temperature Testing*—Position the specimen properly (see Figs. 3 and 4). Activate the equipment

5.7 *Frequency Counter*, shall be able to measure frequencies to within ± 1 Hz.

5.8 If data at elevated temperature are desired, a furnace shall be used that is capable of controlled heating and cooling. It shall have a specimen zone 180 mm in length, which will be uniform in temperature within ± 5 °C throughout the range of temperatures encountered in testing.

5.9 For data at cryogenic temperatures, any chamber shall suffice that shall be capable of controlled heating, frost-free, and uniform in temperature within ± 5 °C over the length of the specimen at any selected temperature. A suitable cryogenic chamber⁴ is shown in Fig. 2.

5.10 Any method of specimen suspension shall be used that shall be adequate for the temperatures encountered in testing and that shall allow the specimen to vibrate without significant restriction. Common cotton thread, silica glass fiber thread, Nichrome, or platinum wire may be used. If metal wire suspension is used in the furnace, coupling characteristics will be improved if, outside the temperature zone, the wire is coupled to cotton thread and the thread is coupled to the transducer. If specimen supports of other than the suspension type are used, they shall meet the same general specifications.

⁴ Smith, R. E. and Hagy, H. E., "A Low Temperature Sonic Resonance Apparatus for Determining Elastic Properties of Solids," *Internal Report 2195*, Corning Glass Works, April 1961.

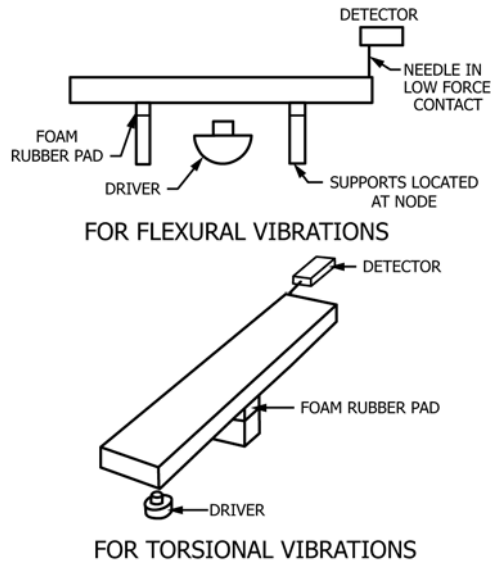
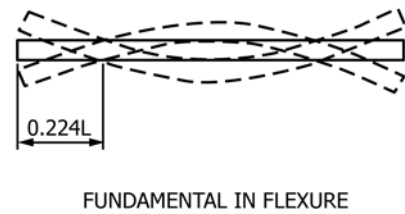
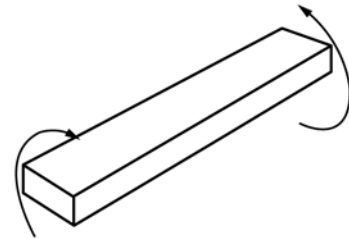

FIG. 4 Specimen Positioned for Measurement of Flexural and Torsional Resonance Frequencies Using “Tweeter” Exciter



FUNDAMENTAL IN FLEXURE



FUNDAMENTAL IN TORSION

FIG. 5 Some Modes of Mechanical Vibration in Bar

so that power adequate to excite the specimen is delivered to the driving transducer. Set the gain of the detector circuit high enough to detect vibration in the specimen and to display it on the oscilloscope screen with sufficient amplitude to measure accurately the frequency at which the signal amplitude is maximized. Adjust the oscilloscope so that a sharply defined horizontal baseline exists when the specimen is not excited. Scan frequencies with the audio oscillator until specimen resonance is indicated by a sinusoidal pattern of maximum amplitude on the oscilloscope. Find the fundamental mode of vibration in flexure, then find the first overtone in flexure (Note 3). Establish definitely the fundamental flexural mode by positioning the detector at the appropriate nodal position of the specimen (see Fig. 5). At this point the amplitude of the resonance signal will decrease to zero. The ratio of the first overtone frequency to the fundamental frequency will be approximately 2.70 to 2.75. If a determination of the shear modulus is to be made, offset the coupling to the transducers so that the torsional mode of vibration may be detected (see Fig. 3). Find the fundamental resonance vibration in this mode. Identify the torsional mode by centering the detector with respect to the width of the specimen and observing that the amplitude of the resonance signal decreases to zero; if it does not, the signal is an overtone of flexure or a spurious frequency generated elsewhere in the system. Dimensions and mass of the specimen may be measured before or after the test. Measure the dimensions with a micrometer caliper capable of an accuracy of ± 0.01 mm; measure the mass with a balance capable of ± 10 mg accuracy.

NOTE 3—It is recommended that the first overtone in flexure be determined for both rectangular and cylindrical specimens. This is useful in establishing the proper identification of the fundamental, particularly when spurious frequencies inherent in the system interfere (as, for example, when greater excitation power and detection sensitivity are required for work with a specimen that has a poor response). The fundamental and overtone are properly identified by showing them to be in the correct numerical ratio, and by demonstrating the proper locations of the nodes for each. Spinner and Tefft recommended using only the

fundamental in flexure when computing Young’s modulus for a rectangular bar because of the approximate nature of Pickett’s theory. However, for the nominal size of bar specified, the values of Young’s modulus computed using Eq 1 and Eq 2 will agree within 1 %. When the correction factor, T_2 , is greater than 2 %, Eq 2 should not be used.

7.2 Procedure B—Elevated Temperature Testing—Determine the mass, dimensions, and frequencies at room temperature in air as outlined in 7.1. Place the specimen in the furnace and adjust the driver-detector system so that all the frequencies to be measured can be detected without further adjustment. Determine the resonant frequencies at room temperature in the furnace cavity with the furnace doors closed, and so forth, as will be the case at elevated temperatures. Heat the furnace at a controlled rate that does not exceed 150 °C/h. Take data at 25° intervals or at 15 min intervals as dictated by heating rate and specimen composition. Follow the change in resonance frequencies with time closely to avoid losing the identity of each frequency. (The overtone in flexure and the fundamental in torsion may be difficult to differentiate if not followed closely; spurious frequencies inherent in the system may also appear at temperatures above 600 °C using certain types of suspensions, particularly wire.) If desired, data may also be taken on cooling; it must be remembered, however, that high temperatures may damage the specimen, by serious warping for example, making subsequent determinations of doubtful value.

7.3 Procedure C—Cryogenic Temperature Testing—Determine the weight, dimensions, and resonance frequencies in air at room temperature. Measure the resonance frequencies at room temperature in the cryogenic chamber. Take the chamber to the minimum temperature desired (Note 4), monitoring frequencies as the chamber is cooled. Allow the specimen to stabilize at minimum temperature for at least 15 min. Take data on heating. Heating rate should not exceed 50 °C/h and data may be taken at intervals of 10 min or 15 °C or as desired.