



Designation: **C913—18** C913 – 21

## Standard Specification for Precast Concrete Water and Wastewater Structures<sup>1</sup>

This standard is issued under the fixed designation C913; the number immediately following the designation indicates the year of original adoption or, in the case of revision, the year of last revision. A number in parentheses indicates the year of last reapproval. A superscript epsilon ( $\epsilon$ ) indicates an editorial change since the last revision or reapproval.

*This standard has been approved for use by agencies of the U.S. Department of Defense.*

### 1. Scope

1.1 This specification covers the recommended design requirements and manufacturing practices for monolithic or sectional precast concrete water and wastewater structures with the exception of concrete pipe, box culverts, utility structures, septic tanks, grease interceptor tanks, and items included under the scope of Specification ~~C478~~C478/C478M.

NOTE 1—Water and wastewater structures are defined as solar heating reservoirs, cisterns, holding tanks, leaching tanks, extended aeration tanks, wet wells, pumping stations, distribution boxes, oil-water separators, treatment plants, manure pits, catch basins, drop inlets, and similar structures.

NOTE 2—Installation and sealant requirements should receive special consideration due to special features of the application.

1.2 The values stated in inch-pound units are to be regarded as the standard. The values given in parentheses are for information only.

1.3 *This standard does not purport to address all of the safety concerns, if any, associated with its use. It is the responsibility of the user of this standard to establish appropriate safety, health, and environmental practices and determine the applicability of regulatory limitations prior to use.*

1.4 *This international standard was developed in accordance with internationally recognized principles on standardization established in the Decision on Principles for the Development of International Standards, Guides and Recommendations issued by the World Trade Organization Technical Barriers to Trade (TBT) Committee.*

### 2. Referenced Documents

#### 2.1 ASTM Standards:<sup>2</sup>

- A184/A184M Specification for Welded Deformed Steel Bar Mats for Concrete Reinforcement
- A416/A416M Specification for Low-Relaxation, Seven-Wire Steel Strand for Prestressed Concrete
- A421/A421M Specification for Stress-Relieved Steel Wire for Prestressed Concrete
- A615/A615M Specification for Deformed and Plain Carbon-Steel Bars for Concrete Reinforcement
- A706/A706M Specification for Deformed and Plain Low-Alloy Steel Bars for Concrete Reinforcement
- A1064/A1064M Specification for Carbon-Steel Wire and Welded Wire Reinforcement, Plain and Deformed, for Concrete
- C33/C33M Specification for Concrete Aggregates
- C39/C39M Test Method for Compressive Strength of Cylindrical Concrete Specimens
- C94/C94M Specification for Ready-Mixed Concrete

<sup>1</sup> This specification is under the jurisdiction of ASTM Committee C27 on Precast Concrete Products and is the direct responsibility of Subcommittee C27.30 on Water and Wastewater Containers.

Current edition approved ~~May 1, 2018~~Aug. 1, 2021. Published ~~May 2018~~August 2021. Originally approved in 1979. Last previous edition approved in ~~2016~~2018 as C913—16-C913 – 18. DOI: ~~10.1520/C0913-18~~10.1520/C0913-21.

<sup>2</sup> For referenced ASTM standards, visit the ASTM website, www.astm.org, or contact ASTM Customer Service at service@astm.org. For *Annual Book of ASTM Standards* volume information, refer to the standard's Document Summary page on the ASTM website.

- C125 Terminology Relating to Concrete and Concrete Aggregates
- C150/C150M Specification for Portland Cement
- C173/C173M Test Method for Air Content of Freshly Mixed Concrete by the Volumetric Method
- C231/C231M Test Method for Air Content of Freshly Mixed Concrete by the Pressure Method
- C260/C260M Specification for Air-Entraining Admixtures for Concrete
- C330/C330M Specification for Lightweight Aggregates for Structural Concrete
- ~~C478/C478M~~ Specification for Circular Precast Reinforced Concrete Manhole Sections ~~(Metric)~~ ~~C0478\_C0478M~~
- C494/C494M Specification for Chemical Admixtures for Concrete
- C595/C595M Specification for Blended Hydraulic Cements
- C618 Specification for Coal Fly Ash and Raw or Calcined Natural Pozzolan for Use in Concrete
- C685/C685M Specification for Concrete Made by Volumetric Batching and Continuous Mixing
- C890 Practice for Minimum Structural Design Loading for Monolithic or Sectional Precast Concrete Water and Wastewater Structures
- ~~C989/C989M~~ Specification for Slag Cement for Use in Concrete and Mortars
- C990 Specification for Joints for Concrete Pipe, Manholes, and Precast Box Sections Using Preformed Flexible Joint Sealants
- C1157/C1157M Performance Specification for Hydraulic Cement
- 2.2 *American Concrete Institute Standard:*
- ACI 318 Building Code Requirements for Reinforced Concrete<sup>3</sup>
- 2.3 *Federal Specification:*
- SS-S-210A Sealing Compound, Preformed Plastic, for Expansion Joints and Pipe Joints<sup>4</sup>

### 3. Ordering Information

3.1 Unless otherwise designated by the purchaser before placing an order, a structure designed in accordance with Section 5 of this specification and found to satisfactorily meet the requirements imposed when tested and inspected as described herein shall be acceptable. The test of materials as required shall be done in accordance with applicable ASTM International standards. Inspection, when required, shall include checks on fabrication and placing of reinforcement and concrete in accordance with approved design drawings.

### 4. Materials

#### 4.1 *Cementitious Materials:*

4.1.1 *Cement*—Cement shall conform to the requirements for portland cement of Specification C150/C150M, hydraulic cement Specification C1157/C1157M, or shall be portland blast-furnace slag cement, portland-limestone cement or portland-pozzolan cement conforming to the requirements of Specification C595/C595M, except that the pozzolan constituent in the Type IP portland-pozzolan cement shall be fly ash.

4.1.2 *Fly Ash*—Fly ash shall conform to the requirements of Specification C618, ~~Class F or Class C.~~

4.1.3 ~~*Ground Granulated Blast-Slag Cement*~~—~~Furnace slag (GGBFS0-GGBFS)~~ Slag cement shall conform to the requirements of Grade 100 or 120 of Specification ~~C890~~C989/C989M.

4.1.4 ~~*Allowable Combinations of Cementitious Material*~~—~~Materials~~—The combination of cementitious materials used in concrete shall be one of the following:

4.1.4.1 Portland cement only;

4.1.4.2 Portland blast furnace slag cement only;

4.1.4.3 ~~Slag-modified portland~~ Portland-limestone cement only;

4.1.4.4 Portland-pozzolan cement only;

4.1.4.5 A combination of portland cement or portland-limestone cement and fly ash;

<sup>3</sup> Available from American Concrete Institute (ACI), P.O. Box 9094, Farmington Hills, MI 48333-9094, <http://www.aci-int.org>.

<sup>4</sup> Available from Standardization Documents, Order Desk, Bldg. 4, Section D, 700 Robbins Ave., Philadelphia, PA 19111-5094. Attn: NPODS.

4.1.4.6 A combination of portland cement and ~~ground granulated blast-furnace slag~~; or portland-limestone cement, slag cement, and fly ash; and

4.1.4.7 A combination of ~~portland cement, ground granulated blast-furnace slag (not to exceed 25 % of the total cementitious weight), and fly ash (not to exceed 25 % of the total cementitious weight)~~; portland-pozzolan cement and fly ash.

4.2 *Aggregates*—Aggregates shall conform to Specification **C33/C33M** and lightweight aggregates shall conform to Specification **C330/C330M**, except that the requirements for grading shall not apply.

4.3 *Water*—Water used in mixing concrete shall be clean and free of injurious amounts of oils, acids, alkalis, salts, organic materials, or other substances incompatible with concrete or steel.

4.4 *Admixtures*—Admixtures shall conform to Specification **C494/C494M** or **C618** and shall not be injurious to other products used in the concrete.

4.4.1 *Air-Entraining Admixtures*—Air-entraining admixtures conforming to Specification **C260/C260M** shall be used when there is a risk that the concrete may be exposed to freeze-thaw cycles. The concrete mixture shall contain  $5.5 \pm 1.5$  % air by volume as determined by Test Method **C231/C231M** or **C173/C173M**.

4.5 *Steel Reinforcement*—Steel reinforcement shall conform to Specification **A1064/A1064M**; Specifications **A416/A416M** and **A421/A421M** for prestressed strand and wire; or Specification **A184/A184M**, **A615/A615M**, or **A706/A706M** for bars.

## 5. Design Requirements

5.1 *Design Method*—The method of structural design of reinforced concrete as outlined in the ACI 318 Building Code shall be used to design the concrete sections, including the reinforcement required, when the structure is subjected to the loading conditions covered in Practice **C890**. Design requirements in excess of these specifications shall be identified by the purchaser.

5.1.1 *Alternative Method to Design*—An alternative method to the design of a structure is acceptable, with the permission of the purchaser, by performing required performance tests on the completed structure to confirm adequate strength.

5.2 *Access Openings*—The structural design shall take into consideration the number, placement, and size of access openings.

5.3 *Floors*—The minimum floor thickness resulting from slope shall be considered as nominal floor thickness in the structure.

5.4 *Knockouts and Sumps*—Knockouts and sumps shall be designed to carry the loads imposed upon them. The basic structure shall be designed to carry all imposed loads with knockouts removed.

5.5 *Placement of Reinforcement*—The minimum concrete cover for reinforcing bars, mats, or fabric shall not be less than 1 in. (25 mm) for water retaining structures and  $\frac{3}{4}$  in. (19 mm) for other structures subject to the provisions of Section 7.

5.6 *Concrete Strength*—The minimum compressive strength ( $f'_c$ ) for design shall be 4000 psi (28 MPa) at 28 days of age.

5.7 *Joints*—Where required, sealed joints in sectional precast concrete structures shall be of such a design to prevent unacceptable leakage when used with a sealant (**Note 3**) approved by the purchaser and acceptable to the manufacturer. The criteria for unacceptable leakage will be determined by the purchaser's specifications. Where potable water is involved, caution advises selecting a sealant that will not contaminate the water for its intended purposes.

NOTE 3—Refer to Specification **C990** or Federal Specification SS-S-210A for guidance.

5.8 *Lifting Devices*—Design of embedded lifting devices shall conform to requirements as specified in 8.4 under Special Loading Considerations of Practice **C890**.

## 6. Manufacture

6.1 *Mixture*—The aggregates, cement, and water shall be proportioned and mixed to produce a homogeneous concrete meeting the requirements of this specification, and in accordance with Specification **C94/C94M** or **C685/C685M**.

6.2 *Forms*—The forms used in manufacture shall be sufficiently rigid and accurate to maintain the dimensions of the structure within the tolerances given in Section 7. All casting surfaces shall be of smooth nonporous material. Form releasing agents used shall not be injurious to the concrete.

6.3 *Reinforcement*—Reinforcement must be securely tied or welded (as allowed by the design) in place to maintain position during concrete placing operations. Where specified all chairs, bolsters, braces, and spacers in contact with forms shall have a corrosion-resistant surface.

6.3.1 Flexural reinforcing steel shall not exceed spacing of 12 in. (30.5 cm) center to center.

6.4 *Concrete Placement*—Concrete shall be placed in the forms at a rate such that the concrete is plastic at all times and consolidates in all parts of the form and around all reinforcement steel and embedded fixtures without segregation of materials.

6.5 *Curing*—The precast concrete sections shall be cured by any method or combination of methods that will develop the specified compressive strength at 28 days or less.

6.6 *Concrete Quality*—The quality of the concrete shall be in accordance with the chapter on concrete quality of ACI 318, current edition, except for frequency of tests, which shall be specified by the purchaser. Concrete strength tests shall be conducted in accordance with Test Method **C39/C39M**.

6.6.1 *Water-Cementitious Ratio*—Concrete that will be exposed to freezing and thawing shall contain entrained air and shall have water-cementitious ratios of 0.45 or less. Concrete that will not be exposed to freezing but that is required to be watertight shall have a water-cementitious ratio of 0.48 or less if the concrete is exposed to fresh water. For corrosion protection, reinforced concrete exposed to deicer salts, brackish water, or seawater shall have water-cementitious ratio of 0.40 or less.

## 7. Tolerances

7.1 *Dimensional Tolerances*—The length, width, height, or diameter measurements of the structure when measured on the inside surface shall not deviate from the design dimensions more than the following:

Dimension	Tolerance
0 to 5 ft (0 to 1.5 m)	±¼ in. (±6 mm)
5 to 10 ft (1.5 to 3.0 m)	±⅜ in. (±10 mm)
10 to 20 ft (3.0 to 6.1 m)	±½ in. (±13 mm)
20 ft (6.1 m) and over	as agreed upon between manufacturer and purchaser

7.2 *Squareness Tolerance*—The inside of the rectangular precast concrete component shall be square as determined by diagonal measurements. The difference between such measurements shall not exceed:

Measured Length	Allowable Difference
0 to 10 ft (0 to 3.0 m)	½ in. (13 mm)
10 to 20 ft (3.0 to 6.1 m)	¾ in. (19 mm)
20 ft (6.1 m) and over	as agreed upon between manufacturer and purchaser

7.3 *Joint Surfaces*—The following joint tolerances for water retaining structures shall apply:

7.3.1 *Flexible Joint*—The inside joint seam gap between two sections placed together before a joint sealant is applied shall not exceed ⅜ in. (10 mm).

7.3.2 *Grout or Mortar Joint*—The opening to be grouted in a grout or mortar joint shall not exceed 1 in. (25 mm).

7.4 *Reinforcement Location*—With reference to thickness of wall or slab, reinforcement shall be within  $\pm\frac{1}{4}$  in. (6 mm) of the design location, but in no case shall the cover be less than 1 in. (25 mm) for water-retaining structures and  $\frac{3}{4}$  in. (19 mm) for non-water retaining structures. The variations in reinforcement spacing shall not be more than one tenth of the designed bar spacing nor exceed  $1\frac{1}{2}$  in. (38 mm). The total number of bars shall not be less than that computed using the design spacing.

7.5 *Slab and Wall Thickness*—The slab and wall thickness shall be uniform and shall not be less than that shown in the design by more than 5 % or  $\frac{3}{8}$  in. (10 mm), whichever is greater. A thickness greater than that required in the design shall not be a cause for rejection.

## 8. Repairs

8.1 Repairs shall be performed by the manufacturer in a manner to ensure that the repaired structure will conform to the requirements of this specification.

## 9. Rejection

9.1 Precast concrete structures or sections of structures shall be subject to rejection because of failure to conform to any of the requirements contained herein.

## 10. Marking

10.1 The following information shall be clearly marked on each structure or section of structure, by indentation, waterproof paint, or other approved means:

10.1.1 Date of manufacture,

10.1.2 Name or trademark of the manufacturer, and

10.1.3 Initials or symbols to indicate the intended use of the structure.

## 11. Keywords

11.1 concrete; precast; structures; wastewater; water

## APPENDIXES

(Nonmandatory Information)

### X1. DESIGNS FOR RECTANGULAR BOXES

#### X1.1 Description of Designs

X1.1.1 The designs in **Table X1.1** are provided as a convenience for specifying, purchasing, and manufacturing. Riser and base sections are shown in **Fig. X1.1**.

X1.1.2 The successful performance of the product depends upon the proper selection (based on field conditions), good manufacturing practices, and proper installation.

X1.1.3 Refer to **Appendix X2** for instructions on the use of the designs.

TABLE X1.1 Designs for Rectangular Boxes<sup>A</sup>

Size L by W	t (in)	d (in)	Class w (psf)	Reinforcing	
				A <sub>sh</sub> (in. <sup>2</sup> /ft)	A <sub>sv</sub> (in. <sup>2</sup> /ft)
2 ft by 2 ft	6	3	300 500 700	0.14	0.14
2 ft 6 in. by 2 ft	6	3	300 500 700	0.14	0.14
2 ft 6 in. by 2 ft 6 in.	6	3	300 500 700	0.14	0.14
3 ft by 2 ft	6	3	300 500 700	0.14	0.14
3 ft by 2 ft 6 in.	6	3	300 500 700	0.14	0.14
3 ft by 3 ft	6	3	300 500 700	0.14	0.14
3 ft 6 in. by 2 ft	6	3	300 500 700	0.14	0.14
3 ft 6 in. by 2 ft 6 in.	6	3	300 500 700	0.14	0.14
3 ft 6 in. by 3 ft	6	3	300 500 700	0.14	0.14
3 ft 6 in. by 3 ft 6 in.	6	3	300 500 700	0.14	0.14
4 ft by 2 ft	6	3	300 500 700	0.14	0.14
4 ft by 2 ft 6 in.	6	3	300 500 700	0.14	0.14
4 ft by 3 ft	6	3	300 500 700	0.14	0.14
4 ft by 3 ft 6 in.	6	3	300 500 700	0.14	0.14
4 ft by 4 ft	6	3	300 500 700	0.14	0.14
4 ft 6 in. by 2 ft 6 in.	6	3	300 500 700	0.14	0.14
4 ft 6 in. by 3 ft	6	3	300 500 700	0.14	0.14
4 ft 6 in. by 3 ft 6 in.	6	3	300 500 700	0.14	0.14
4 ft 6 in. by 4 ft	6	3	300 500 700	0.14	0.14
4 ft 6 in. by 4 ft 6 in.	6	3	300 500 700	0.14	0.14
6 ft by 5 ft 6 in.	6	3	300	0.14	0.14
6 ft by 5 ft 6 in.	6	3	500	0.17	0.14
6 ft by 5 ft 6 in.	6	3	700	0.24	0.14
6 ft by 6 ft	6	3	300	0.14	0.14
6 ft by 6 ft	6	3	500	0.18	0.14
6 ft by 6 ft	6	3	700	0.27	0.14

<sup>A</sup> One in. = 25.0 mm.

iTeh Standards  
(<https://standards.iteh.ai>)  
Document Review



ASTM C913-21

<https://standards.iteh.ai/catalog/standards/sist/fdfl2145144cf9ec2-a6fla920c090/astm-c913-21>

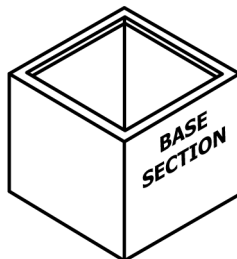
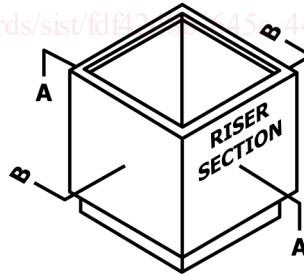

FIG. X1.1 Typical Assembly

## X1.2 Structural Analysis

X1.2.1 The analysis is based on the slope-deflection solution of a frame with nonprismatic members.

X1.2.2 Loads are based on Practice C890.

## X1.3 Design Calculations

X1.3.1 The concrete shall be designed to be proportioned for  $f'_c = 4000$  psi (28 MPa).

X1.3.2 Reinforcing steel shall be Grade 60 (minimum yield strength of 60 000 psi) (3.84 MPa).

X1.3.3 The strength design method described in ACI-318 is used with U.L.F. = 1.7.

X1.3.4 Minimum reinforcement is 0.002 times the gross concrete area of the cross section.

X1.3.5 Calculations for units with integral slab (top or bottom) do not take into consideration rigidity or support from slab.

## X1.4 Definitions

ASTM C913-21

<https://standards.iteh.ai/catalog/standards/sist/fd4248b-645e-44cf-9ec2-a6f1a920c090/astm-c913-21>

X1.4.1  $t$ —Total thickness of wall (Fig. X1.2).

X1.4.2  $d$ —Distance from centerline of horizontal steel to inside face of wall (Fig. X1.2).

X1.4.3  $A_{sh}$ —Area of horizontal steel per vertical foot (Fig. X1.2).

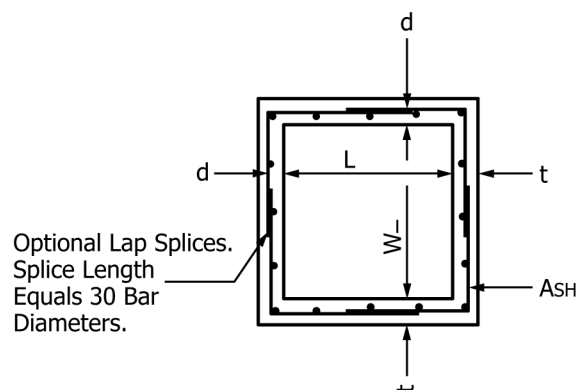

FIG. X1.2 Section AA