



Designation: **C890—19** **C890 – 21**

Standard Practice for Minimum Structural Design Loading for Monolithic or Sectional Precast Concrete Water and Wastewater Structures¹

This standard is issued under the fixed designation C890; the number immediately following the designation indicates the year of original adoption or, in the case of revision, the year of last revision. A number in parentheses indicates the year of last reapproval. A superscript epsilon (ϵ) indicates an editorial change since the last revision or reapproval.

1. Scope

1.1 This practice describes the minimum loads to be applied when designing monolithic or sectional precast concrete water and wastewater structures with the exception of concrete pipe, box culverts, utility structures, and material covered in Specification ~~C478C478/C478M~~.

1.2 The values stated in inch-pound units are to be regarded as standard. The values given in parentheses are mathematical conversions to SI units that are provided for information only and are not considered standard.

1.3 *This standard does not purport to address all of the safety concerns, if any, associated with its use. It is the responsibility of the user of this standard to establish appropriate safety, health, and environmental practices and determine the applicability of regulatory limitations prior to use.*

1.4 *This international standard was developed in accordance with internationally recognized principles on standardization established in the Decision on Principles for the Development of International Standards, Guides and Recommendations issued by the World Trade Organization Technical Barriers to Trade (TBT) Committee.*

2. Referenced Documents

2.1 *ASTM Standards:*²

~~C478C478/C478M~~ Specification for Circular Precast Reinforced Concrete Manhole Sections (Metric) ~~C0478_C0478M~~

2.2 *AASHTO Standard:*

Standard Specifications for Highway Bridges, 16th Edition³

2.3 *ACI Standard:*

ACI 318 Building Code Requirements for Reinforced Concrete⁴

3. Terminology

3.1 *Definitions of Terms Specific to This Standard:*

3.1.1 *above ground structures*—*structures, n*—all structures with their base at or above ground.

¹ This practice is under the jurisdiction of ASTM Committee C27 on Precast Concrete Products and is the direct responsibility of Subcommittee C27.30 on Water and Wastewater Containers.

Current edition approved July 1, 2019/Aug. 1, 2021. Published July 2019/August 2021. Originally approved in 1978. Last previous edition approved in 2013/2019 as C890—13—19. DOI: 10.1520/C0890-19.10.1520/C0890-21.

² For referenced ASTM standards, visit the ASTM website, www.astm.org, or contact ASTM Customer Service at service@astm.org. For *Annual Book of ASTM Standards* volume information, refer to the standard's Document Summary page on the ASTM website.

³ Available from American Association of State Highway and Transportation Officials (AASHTO), 444 N. Capitol St., NW, Suite 249, Washington, DC 20001, http://www.transportation.org.

⁴ Available from American Concrete Institute (ACI), P.O. Box 9094, Farmington Hills, MI 48333-9094, http://www.concrete.org.

- 3.1.2 *bearing loads*—loads, n—the foundation pressure reaction to all other loads acting on the structure.
- 3.1.3 *below ground structures*—structures, n—all structures other than those with their base at or above ground.
- 3.1.4 *dead loads*—loads, n—the mass of the structure and all permanent loads imposed on the structure.
- 3.1.5 *equipment loads*—loads, n—loads induced into the structure by equipment installed on mounting devices cast into the structure.
- 3.1.6 *hydrostatic loads*—loads, n—all pressures due to the weight of water or other liquids.
- 3.1.7 *lateral earth loads*—loads, n—the lateral pressure due to the effective weight of adjacent earth backfill.
- 3.1.8 *lifting loads*—loads, n—the forces induced into the structure during handling at the precast plant and the construction site.
- 3.1.9 *surcharge loads*—loads, n—the lateral pressure due to vertical loads superimposed on the adjacent earth backfill.
- 3.1.10 *traffic loads*—loads, n—all loads superimposed on the structure or adjacent earth backfill due to vehicles or pedestrians.
- 3.1.11 *water and wastewater structures*—structures, n—solar heating reservoirs, septic tanks, cisterns, holding tanks, leaching tanks, extended aeration tanks, wet wells, pumping stations, grease traps, distribution boxes, oil-water separators, treatment plants, manure pits, catch basins, drop inlets, and similar structures.

4. Significance and Use

- 4.1 This practice is intended to standardize the minimum loads to be used to structurally design a precast product.
- 4.2 The user is cautioned that he must properly correlate the anticipated field conditions and requirements with the design loads. Field conditions may dictate loads greater than minimum.

5. Design Loads

5.1 *Dead Loads:*

- 5.1.1 Permanent vertical loads typically include the weight of the road bed, walkways, earth backfill, and access opening covers.
- 5.1.2 Recommended unit weights of materials for design are shown in **Table 1**.

5.2 *Traffic Loads:*

- 5.2.1 The vehicle and pedestrian loadings are shown in **Table 2**.
- 5.2.2 The arrangement and spacing of vehicle wheels are shown in **Fig. 1** and **Fig. 2**.

5.2.3 *Distribution of Wheel Loads through Earth Fills:*

TABLE 1 Unit Weights of Materials

Material	Weight, lbf/ft ³ (N/m ³)
Concrete (plain or reinforced)	150 (23 600)
Lightweight Concrete (reinforced)	100 to 130 (15 700 to 20 400)
Cast Iron	450 (70 700)
Steel	490 (77 000)
Aluminum	175 (27 500)
Earth Fill	100 to 150 (15 700 to 23 600)
Macadam	140 (22 000)

TABLE 2 Vehicle and Pedestrian Load Designations

Designation	Load, max	Uses
A-16 (HS20-44) ^A	16 000 lbf (71 200 N) per wheel	heavy traffic
A-12 (HS15-44) ^A	12 000 lbf (53 400 N) per wheel	medium traffic
A-8 (H10-44) ^A	8000 lbf (35 600 N) per wheel	light traffic
A-03	300 lbf/ft ² (14 400 Pa)	walkways

^A The designations in parentheses are corresponding AASHTO designations.

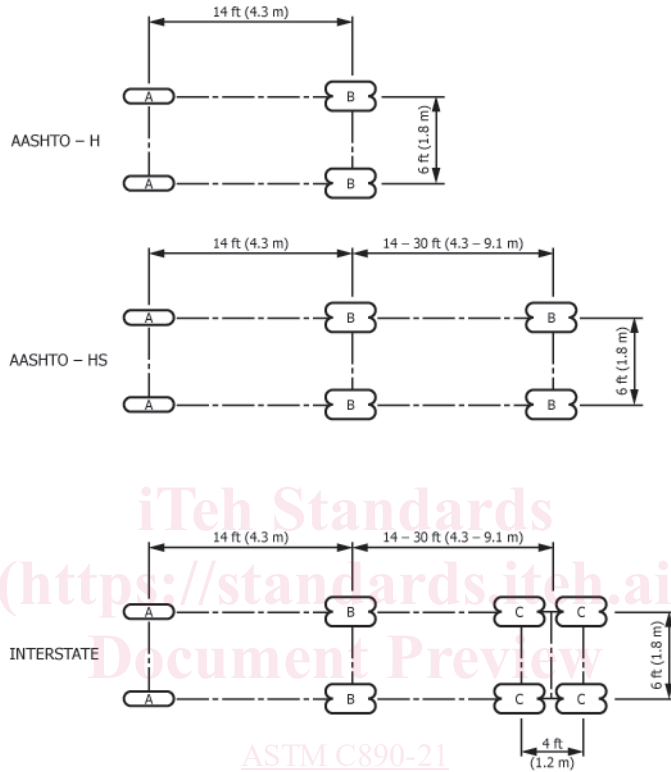

Designation	Load at A		Load at B		Load at C	
	lbf	N	lbf	N	lbf	N
A-16 (HS20-44) ^A	4000	17 800	16 000	71 200	12 500	55 625
A-16 (HS20-44) ^A	4000	17 800	16 000	71 200	12 500	55 600
A-12 (HS15-44) ^A	3000	13 300	12 000	53 400	8375	37 270
A-12 (HS15-44) ^A	3000	13 300	12 000	53 400	9380	41 700
A-8 (H10-44) ^A	2000	8900	8000	35 600	6250	27 812
A-8 (H10-44) ^A	2000	8900	8000	35 600	6250	27 800

^A The designations in parentheses are corresponding AASHTO designations.

FIG. 1 Single Vehicle Traffic Loads and Spacing

5.2.3.1 For structures where vehicle wheels contact the top surface of the structure, the vehicle wheel loads will be distributed over an area as shown in Fig. 3. The loaded area will be:

$$A = W \times L \tag{1}$$

where:

- A = wheel load area, ft² (m²),
- W = wheel width, ft (m), and
- L = wheel length, ft (m).

AASHTO & INTERSTATE

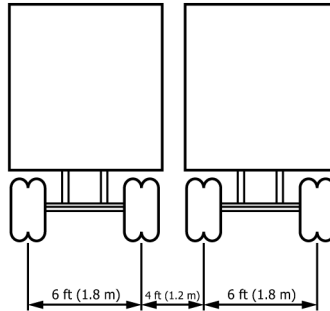

FIG. 2 Multiple Vehicle Spacing

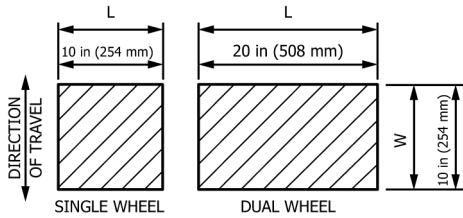

FIG. 3 Wheel Load Area

5.2.3.2 For below ground structures where backfill separates the vehicle wheels and the top surface of the structure, the vehicle wheel loads will be distributed as a truncated pyramid as shown in Fig. 4.

The loaded area will be:

$$A = (W + 1.75 H) \times (L + 1.75 H) \quad (2)$$

where:

A = wheel load area, ft² (m²),

W = wheel width, ft (m),

L = wheel length, ft (m), and

H = height of backfill between wheels and structure, ft (m).

5.2.3.3 When several distributed wheel load areas overlap, the total wheel load will be uniformly distributed over a composite area defined by the outside limits of the individual areas. Such a wheel load distribution is shown in Fig. 5.

5.2.3.4 When the dimensions of the distributed load area or the composite distributed load area exceed the top surface area of the structure, only that portion of the distributed load within the top surface area will be considered in the design.

5.2.4 The effects of impact will increase the live wheel loads designated as A-16, A-12, and A-8 as shown in Table 3.

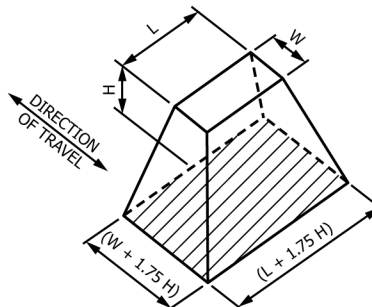

FIG. 4 Distributed Load Area

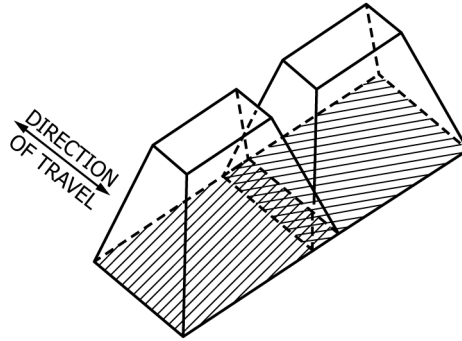

FIG. 5 Composite Distributed Load Area

TABLE 3 Wheel Load Increases for Impact

Height of Backfill Between Wheel and Structure	Increase
0 to 12 in. (0 to 305 mm)	30 %
13 to 24 in. (330 to 610 mm)	20 %
25 to 35 in. (635 to 890 mm)	10 %
36 in. (915 mm) or greater	0 %

5.3 Hydrostatic Loads:

5.3.1 The water pressure acting on any point on the outside surface of the structure is:

$$P_w = W_w \times H_w \tag{3}$$

where:

- P_w = hydrostatic pressure, lbf/ft² (Pa),
- W_w = unit weight of water, lbf/ft³ (N/m³), and
- H_w = distance from the ground water surface to the point on the structure under consideration, ft (m).

5.3.2 The liquid pressure acting on any point on the inside surface of the structure is:

$$P_L = W_L \times H_L \tag{4}$$

where:

- P_L = liquid pressure, lbf/ft² (Pa),
- W_L = unit weight of the liquid, lbf/ft³ (N/m³), and
- H_L = distance from the liquid surface to the point on the structure under consideration, ft (m).

5.4 Lateral Earth Loads:

5.4.1 The lateral earth pressure on the walls of a buried structure for the portion of the walls above the ground water surface will be:

$$P_E = K \times W_E \times H_E \tag{5}$$

where:

- P_E = lateral earth pressure, lbf/ft² (Pa),
- K = coefficient of lateral earth pressure,
- W_E = unit weight of the earth backfill, lbf/ft³ (N/m³), and
- H_E = distance from the surface of the earth backfill to the point on the structure walls under consideration, ft (m).

5.4.2 The lateral earth pressure on the walls of a buried structure for the portion of the walls below the ground water surface will be: