International Standard



4970

INTERNATIONAL ORGANIZATION FOR STANDARDIZATION • МЕЖДУНАРОДНАЯ ОРГАНИЗАЦИЯ ПО СТАНДАРТИЗАЦИИ • ORGANISATION INTERNATIONALE DE NORMALISATION

Steel — Determination of total or effective thickness of thin surface-hardened layers

Acier — Détermination de l'épaisseur totale ou conventionnelle des couches minces durcies superficielles

First edition — 1979-11-01

ITeH STANDARD PREVIEW
(standards.iteh.ai)

[ISO 4970:1979](#)

<https://standards.iteh.ai/catalog/standards/sist/c7f32867-7336-475c-8a25-0331f076f247/iso-4970-1979>

UDC 669.14 : 620.17 : 621.785.5

Ref. No. ISO 4970-1979 (E)

Descriptors : steels, case hardening, dimensional measurement, thickness, metallography, micrography, hardness tests.

Foreword

ISO (the International Organization for Standardization) is a worldwide federation of national standards institutes (ISO member bodies). The work of developing International Standards is carried out through ISO technical committees. Every member body interested in a subject for which a technical committee has been set up has the right to be represented on that committee. International organizations, governmental and non-governmental, in liaison with ISO, also take part in the work.

Draft International Standards adopted by the technical committees are circulated to the member bodies for approval before their acceptance as International Standards by the ISO Council.

International Standard ISO 4970 was developed by Technical Committee ISO/TC 17, *Steel*, and was circulated to the member bodies in May 1978.

ITeH STANDARD PREVIEW
(standards.iteh.ai)

It has been approved by the member bodies of the following countries :

[ISO 4970:1979](https://standards.iteh.ai/catalog/standards/sist/c7f32867-7336-475c-8a25-0331f076347a/iso-4970-1979)

Austria	Hungary	Portugal
Belgium	India	Romania
Brazil	Iran	South Africa, Rep. of
Bulgaria	Ireland	Spain
Canada	Italy	Sweden
Chile	Japan	Switzerland
Czechoslovakia	Korea, Dem. P. Rep. of	Turkey
Denmark	Korea, Rep. of	United Kingdom
Egypt, Arab Rep. of	Mexico	USA
Finland	Netherlands	USSR
France	Norway	
Germany, F. R.	Poland	

The member body of the following country expressed disapproval of the document on technical grounds :

Australia

Steel — Determination of total or effective thickness of thin surface-hardened layers

1 Scope and field of application

This International Standard specifies a method of measuring the total or effective thickness of thin surface-hardened layers, with thicknesses of less than or equal to 0,3 mm, obtained, for example, by mechanical (shot blasting, shot peening, etc.), thermal (flame or induction hardening, etc.) or thermochemical (carbonitriding, carburizing and hardening, etc.) treatment.

It is not applicable to thin surface layers which are not continuous with the basis metal.

NOTE — Surface-hardened layers with thicknesses of more than 0,3 mm are covered by ISO 2639, *Steel — Determination and verification of the effective depth of carburized and hardened cases*; and ISO 3754, *Steel — Determination of effective depth of hardening after flame or induction hardening*.

2 Methods of measurement

The two methods usually selected are :

- the micrographic method;
- the microhardness measurement method.

The choice of the method and its accuracy depend on the nature of the thin layer and on its presumed thickness. Since the method used also affects the result obtained, the choice has to be made by prior agreement between the parties concerned.

2.1 Micrographic method

This method consists in examining the structural variations, from the periphery inwards to the centre, brought about by the treatment.

The total thickness of the thin surface layer is defined as the distance from the surface examined to the limit beyond which no visible structural variation is detected, as compared with the structure of the unaffected metal.

The effective thickness is defined as the distance from the surface examined to the limit of a reference structure.¹⁾

2.1.1 Selection and preparation of sample

The sample may be one of the following types :

a) a section perpendicular to the longitudinal axis of the product, or, if the product has no longitudinal axis, a section perpendicular to the surface at a location to be agreed between the parties concerned;

b) a longitudinal section obtained by machining a 1 mm deep flat (this method applies only to round bars — see figure 1); other depths of flat may be specified;

c) an oblique section; the thinner the layer, the more acute the angle α between the plane of the section and the surface must be (see figure 2). As it is a difficult operation to determine the angle α , it is preferable, wherever possible, to use an oblique section with a groove having a depth close to the presumed thickness of the thin layer (see figure 3). It is then possible to calculate the thickness of the thin layer without having to measure the angle α (see 2.1.2).

Small samples (with a section of less than 4 cm²) shall be examined all round their perimeter. Where samples are large, several samples shall be selected to ensure that they are fully representative. Sections taken from the corners of polygonal products, being special points, shall not be included.

The number and relative position of the various samplings shall be specified by agreement between the parties concerned.

Using the customary methods, micrographic polishing shall be carried out so as to avoid rounding off the sharp edges of the section, thus varying the angle of the oblique section. To ensure that this does not occur, the sample shall be mounted or shall be held in a clamp. The surface of the product may, if necessary, be protected by depositing a metal coating on it electrolytically.

Etching using 2 to 4 % nital (i.e. a 2 to 4 % solution of nitric acid in alcohol) or another appropriate reagent, will show up the structure of the steel.

1) When, for example, the reference structure is martensitic, the effective thickness is termed martensitic.

2.1.2 Measurement

The total or effective thickness of the thin layer shall be measured either using a micrometer eyepiece, or directly on the ground glass screen of a projection microscope. In most cases the recommended minimum magnification is 200 ×.

By a preliminary examination at low magnification it will be possible to ensure that there is no significant variation in the thickness of the surface layer along the perimeter examined.

Several measurements (at least five) shall be taken on the part where the surface layer shows a uniform thickness, and these shall be taken at regularly spaced points. The thickness of the surface layer is taken as the average of these measurements.

NOTES

1 In the case of the machined flat (see figure 1), the thickness of the layer, *e*, is given by the formula

$$e = R - \sqrt{R^2 + b^2 - 2b\sqrt{2Rf - f^2}}$$

where

- b* is the distance measured on the flat;
- f* is the depth of the flat;
- R* is the radius of the sample.

If the flat is 1 mm deep, this formula is simplified as follows :

$$e = R - \sqrt{R^2 + b^2 - 2b\sqrt{2R - 1}}$$

2 In the case of a simple oblique section (see figure 2), the thickness of the layer, *e*, is given by the formula

$$e = l \sin \alpha$$

where

- l* is the distance measured;
- α* is the angle of the oblique section.

3 In the case of a grooved oblique section (see figure 3), the thickness of the layer, *e*, is given by the formula

$$e = e' \frac{l}{l'}$$

where

- l* is the distance measured;
- l'* is the length of the groove on the oblique section;
- e'* is the depth of the groove.

2.2 Microhardness measurement method

This method consists in determining the changes in Vickers microhardness¹⁾ under a 2,94 N (300 gf) load, measured from the circumference inwards to the centre of the product.

Where the thickness of the hardened surface layer is not compatible with the size of the impression, other loads may be used by prior agreement between the parties concerned.

The total thickness of the thin surface layer is defined by the distance from the surface to the limit beyond which the hardness of the unaffected metal is reached.

The effective thickness is defined by the distance from the surface to the limit beyond which the required hardness (reference hardness) is reached.

2.2.1 Selection and preparation of sample

The sample may be one of the following types :

- a) a section perpendicular to the longitudinal axis of the product, or, if the product has no longitudinal axis, a section perpendicular to the surface at a location to be agreed between the parties concerned (this section is identical to that used in the micrographic examination);
- b) a longitudinal section identical to that used in the micrographic examination;
- c) a test piece with steps : these steps are precision-ground from the surface of the product to the part where the structure is that of the basis metal, and are 0,05 or 0,10 mm thick (see figure 4); the stepped test piece is to be used when a limiting value for the thickness of the surface layer is specified;
- d) a simple or grooved oblique section identical to that used in the micrographic examination.

The sample is prepared in exactly the same way as for the micrographic method, although the sample does not undergo etching, in order to simplify the measurement of the size of the impression. During the machining of the steps, precautions shall be taken to avoid causing any structural changes as a result of grinding.

1) The Knoop microhardness method may be used.

2.2.2 Measurement

The hardness impressions shall be situated along one or several parallel lines normal to the surface and inside a 1,5 mm wide interval, W (see figure 5). The first impression shall be situated at a distance from the surface equal to approximately twice the length of its diagonal.

The distance between two adjacent impressions, S , shall not be less than 2,5 times the length of the diagonal. The difference between the distances from each impression to the surface ($d_2 - d_1$ for example) shall not exceed 0,1 mm, and the accumulated distance shall be measured to an accuracy of $\pm 25 \mu\text{m}$. The diagonals of the impressions shall be measured to an accuracy of $\pm 0,75 \mu\text{m}$.

The impressions shall be made under a 2,94 N (300 gf) load and measured with the aid of an optical device providing a magnification of about $400 \times$.

These determinations shall be carried out on the surface in two specific areas to be agreed between the parties concerned. For each one of these areas, the results shall provide data for plot-

ting a graph of variations in hardness against the distance to the surface.

NOTE — In the case of the machined flat or the oblique section, the thickness of the layer is calculated using the formulae in 2.1.2.

3 Test report

The test report shall contain the following information :

- the grade and the treatment of the material;
- the number and locations of samples taken from the piece;
- the method of measuring adopted, and the procedure;
- the type of thickness measured (total or effective);
- the results of measurements enabling the thickness of the surface layer to be defined;
- any abnormalities observed during measurement;
- any incidents occurring during measurement.

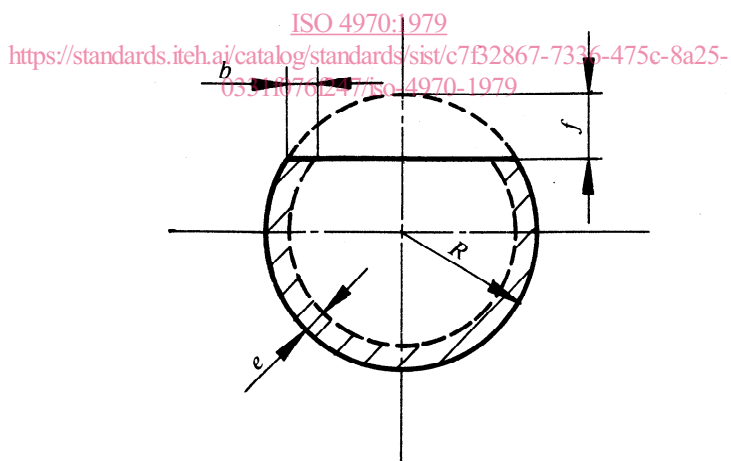

Figure 1 — Longitudinal section obtained by machining a flat

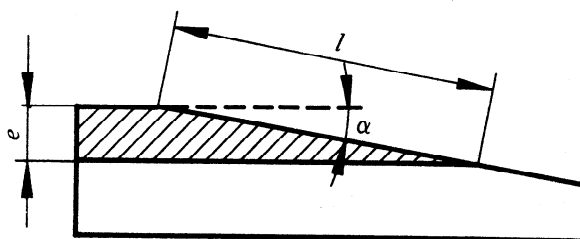

Figure 2 — Simple oblique section

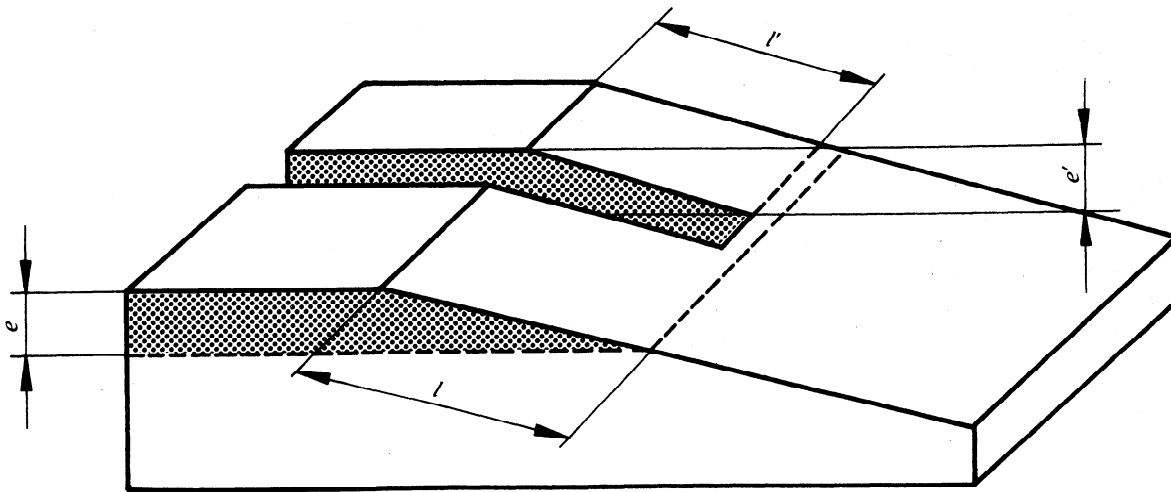

Figure 3 — Grooved oblique section

iTeh STANDARD PREVIEW
(standards.iteh.ai)

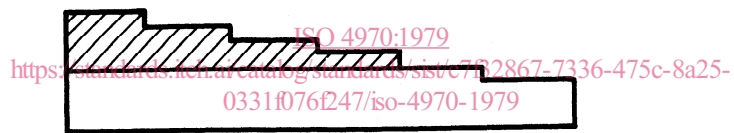

Figure 4 — Stepped test piece

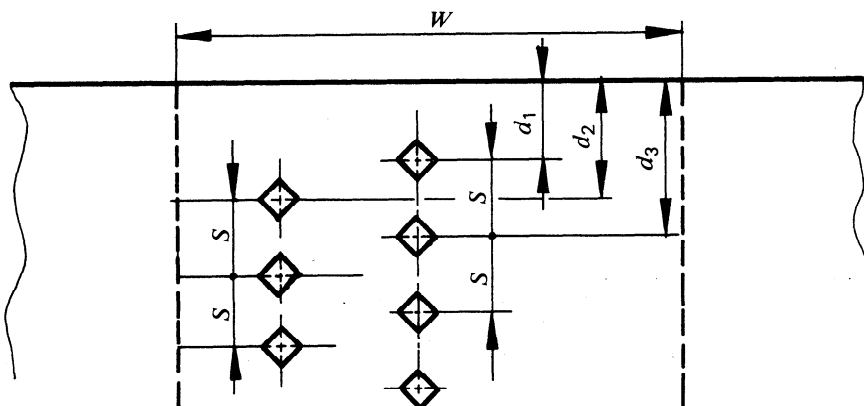

Figure 5 — Siting of the microhardness impressions

iTeh STANDARD PREVIEW
(standards.iteh.ai)

This page intentionally left blank

[ISO 4970:1979](#)

<https://standards.iteh.ai/catalog/standards/sist/c7f32867-7336-475c-8a25-0331f076f247/iso-4970-1979>

iTeh STANDARD PREVIEW
(standards.iteh.ai)

This page intentionally left blank

[ISO 4970:1979](#)

<https://standards.iteh.ai/catalog/standards/sist/c7f32867-7336-475c-8a25-0331f076f247/iso-4970-1979>