

# INTERNATIONAL STANDARD

## NORME INTERNATIONALE

**Electrical installations of buildings –  
Part 5-52: Selection and erection of electrical equipment – Wiring systems**

**Installations électriques des bâtiments –  
Partie 5-52: Choix et mise en œuvre des matériels électriques – Canalisations**

IEC 60364-5-52:2001

<https://standards.iteh.ai/standards/iec/2582829e-fb56-4c88-aad8-fbdf55b40b09/iec-60364-5-52-2001>



## THIS PUBLICATION IS COPYRIGHT PROTECTED

Copyright © 2001 IEC, Geneva, Switzerland

All rights reserved. Unless otherwise specified, no part of this publication may be reproduced or utilized in any form or by any means, electronic or mechanical, including photocopying and microfilm, without permission in writing from either IEC or IEC's member National Committee in the country of the requester.

If you have any questions about IEC copyright or have an enquiry about obtaining additional rights to this publication, please contact the address below or your local IEC member National Committee for further information.

Droits de reproduction réservés. Sauf indication contraire, aucune partie de cette publication ne peut être reproduite ni utilisée sous quelque forme que ce soit et par aucun procédé, électronique ou mécanique, y compris la photocopie et les microfilms, sans l'accord écrit de la CEI ou du Comité national de la CEI du pays du demandeur.

Si vous avez des questions sur le copyright de la CEI ou si vous désirez obtenir des droits supplémentaires sur cette publication, utilisez les coordonnées ci-après ou contactez le Comité national de la CEI de votre pays de résidence.

IEC Central Office  
3, rue de Varembe  
CH-1211 Geneva 20  
Switzerland  
Email: [inmail@iec.ch](mailto:inmail@iec.ch)  
Web: [www.iec.ch](http://www.iec.ch)

### About the IEC

The International Electrotechnical Commission (IEC) is the leading global organization that prepares and publishes International Standards for all electrical, electronic and related technologies.

### About IEC publications

The technical content of IEC publications is kept under constant review by the IEC. Please make sure that you have the latest edition, a corrigenda or an amendment might have been published.

- Catalogue of IEC publications: [www.iec.ch/searchpub](http://www.iec.ch/searchpub)

The IEC on-line Catalogue enables you to search by a variety of criteria (reference number, text, technical committee,...). It also gives information on projects, withdrawn and replaced publications.

- IEC Just Published: [www.iec.ch/online\\_news/justpub](http://www.iec.ch/online_news/justpub)

Stay up to date on all new IEC publications. Just Published details twice a month all new publications released. Available on-line and also by email.

- Electropedia: [www.electropedia.org](http://www.electropedia.org)

The world's leading online dictionary of electronic and electrical terms containing more than 20 000 terms and definitions in English and French, with equivalent terms in additional languages. Also known as the International Electrotechnical Vocabulary online.

- Customer Service Centre: [www.iec.ch/webstore/custserv](http://www.iec.ch/webstore/custserv)

If you wish to give us your feedback on this publication or need further assistance, please visit the Customer Service Centre FAQ or contact us:

Email: [csc@iec.ch](mailto:csc@iec.ch)  
Tel.: +41 22 919 02 11  
Fax: +41 22 919 03 00

### A propos de la CEI

La Commission Electrotechnique internationale (CEI) est la première organisation mondiale qui élabore et publie des normes internationales pour tout ce qui a trait à l'électricité, à l'électronique et aux technologies apparentées.

### A propos des publications CEI

Le contenu technique des publications de la CEI est constamment revu. Veuillez vous assurer que vous possédez l'édition la plus récente, un corrigendum ou amendement peut avoir été publié.

- Catalogue des publications de la CEI: [www.iec.ch/searchpub/cur\\_fut-f.htm](http://www.iec.ch/searchpub/cur_fut-f.htm)

Le Catalogue en-ligne de la CEI vous permet d'effectuer des recherches en utilisant différents critères (numéro de référence, texte, comité d'études,...). Il donne aussi des informations sur les projets et les publications retirées ou remplacées.

- Just Published CEI: [www.iec.ch/online\\_news/justpub](http://www.iec.ch/online_news/justpub)

Restez informé sur les nouvelles publications de la CEI. Just Published détaille deux fois par mois les nouvelles publications parues. Disponible en-ligne et aussi par email.

- Electropedia: [www.electropedia.org](http://www.electropedia.org)

Le premier dictionnaire en ligne au monde de termes électroniques et électriques. Il contient plus de 20 000 termes et définitions en anglais et en français, ainsi que les termes équivalents dans les langues additionnelles. Egalement appelé Vocabulaire Electrotechnique International en ligne.

- Service Clients: [www.iec.ch/webstore/custserv/custserv\\_entry-f.htm](http://www.iec.ch/webstore/custserv/custserv_entry-f.htm)

Si vous désirez nous donner des commentaires sur cette publication ou si vous avez des questions, visitez le FAQ du Service clients ou contactez-nous:

Email: [csc@iec.ch](mailto:csc@iec.ch)  
Tél.: +41 22 919 02 11  
Fax: +41 22 919 03 00

# INTERNATIONAL STANDARD

# NORME INTERNATIONALE

**Electrical installations of buildings –  
Part 5-52: Selection and erection of electrical equipment – Wiring systems**

**Installations électriques des bâtiments –  
Partie 5-52: Choix et mise en œuvre des matériels électriques – Canalisations**

<https://standards.iteh.ai/standards/iec/25382829e-fb56-4c88-aad8-fbdf55b40b09/iec-60364-5-52-2001>

<https://standards.iteh.ai/standards/iec/25382829e-fb56-4c88-aad8-fbdf55b40b09/iec-60364-5-52-2001>

INTERNATIONAL  
ELECTROTECHNICAL  
COMMISSION

COMMISSION  
ELECTROTECHNIQUE  
INTERNATIONALE

PRICE CODE  
CODE PRIX

**XB**

## CONTENTS

FOREWORD.....	5
520 Introduction.....	6
520.1 Scope.....	6
520.2 Normative references.....	6
520.3 General.....	13
521 Types of wiring systems.....	13
522 Selection and erection of wiring systems in relation to external influences.....	15
522.1 Ambient temperature (AA).....	15
522.2 External heat sources.....	15
522.3 Presence of water (AD).....	15
522.4 Presence of solid foreign bodies (AE).....	16
522.5 Presence of corrosive or polluting substances (AF).....	16
522.6 Impact (AG).....	16
522.7 Vibration (AH).....	16
522.8 Other mechanical stresses (AJ).....	16
522.9 Presence of flora and/or mould growth (AK).....	17
522.10 Presence of fauna (AL).....	17
522.11 Solar radiation (AN).....	17
522.12 Seismic effects (AP).....	18
522.13 Wind (AS).....	18
522.14 Nature of processed or stored materials (BE).....	18
522.15 Building design (CB).....	18
523 Current-carrying capacities.....	18
524 Cross-sectional areas of conductors.....	39
525 Voltage drop in consumers' installations.....	21
526 Electrical connections.....	21
527 Selection and erection of wiring systems to minimize the spread of fire.....	22
527.1 Precautions within a fire-segregated compartment.....	22
527.2 Sealing of wiring system penetrations.....	22
528 Proximity of wiring systems to other services.....	23
528.1 Proximity to electrical services.....	23
528.2 Proximity to non-electrical services.....	24
529 Selection and erection of wiring systems in relation to maintainability, including cleaning.....	24
Annex A (normative) Current-carrying capacities.....	25
Annex B (informative) Example of a method of simplification of the tables of clause 523.....	51
Annex C (informative) Formulae to express current-carrying capacities.....	55
Annex D (informative) Effect of harmonic currents on balanced three-phase systems.....	58
Annex E (informative) IEC 60364 – Parts 1 to 6: Restructuring.....	60
Bibliography.....	64

Table 52-1 (52F) – Selection of wiring systems.....	8
Table 52-2 (52G) – Erection of wiring systems.....	8
Table 52-3 (52H) – Examples of methods of installation providing instructions for obtaining current-carrying capacity .....	9
Table 52-4 (52-A) – Maximum operating temperatures for types of insulation.....	18
Table 52-5 (52J) – Minimum cross-sectional area of conductors .....	21
Table A.52-1 (52-B1) – Schedule of reference methods of installation which form the basis of the tabulated current-carrying capacities.....	30
Table A.52-2 (52-C1) – Current-carrying capacities in amperes for methods of installation in table A.52-1 (52-B1) – PVC insulation/two loaded conductors/copper or aluminium – Conductor temperature: 70 °C/Ambient temperature: 30 °C in air, 20 °C in ground .....	32
Table A.52-3 (52-C2) – Current-carrying capacities in amperes for methods of installation in table A.52-1 (52-B1) – XLPE or EPR insulation/two loaded conductors/copper or aluminium – Conductor temperature: 90 °C/Ambient temperature: 30 °C in air, 20 °C in ground .....	33
Table A.52-4 (52-C3) – Current-carrying capacities in amperes for methods of installation in table A.52-1 (52-B1) – PVC insulation/three loaded conductors/copper or aluminium – Conductor temperature: 70 °C/Ambient temperature: 30 °C in air, 20 °C in ground .....	34
Table A.52-5 (52-C4) – Current-carrying capacities in amperes for methods of installation in table A.52-1 (52-B1) – XLPE or EPR insulation/three loaded conductors/copper or aluminium – Conductor temperature: 90 °C/Ambient temperature: 30 °C in air, 20 °C in ground .....	35
Table A.52-6 (52-C5) – Current-carrying capacities in amperes for installation method C of table A.52-1 (52-B1) – Mineral insulation/copper conductors and sheath – PVC covered or bare exposed to touch (see note 2) Metallic sheath temperature: 70 °C/Reference ambient temperature: 30 °C.....	36
Table A.52-7 (52-C6) – Current-carrying capacities in amperes for installation method C of table A.52-1 (52-B1) – Mineral insulation/copper conductors and sheath – Bare cable not exposed to touch and not in contact with combustible material Metallic sheath temperature: 105 °C/Reference ambient temperature: 30 °C.....	37
Table A.52-8 (52-C7) – Current-carrying capacities in amperes for installation methods E, F and G of table A.52-1 (52-B1) – Mineral insulation/Copper conductors and sheath/PVC covered or bare exposed to touch (see note 2) Metallic sheath temperature: 70 °C/Reference ambient temperature: 30 °C .....	38
Table A.52-9 (52-C8) – Current-carrying capacities in amperes for installation methods E, F and G of table A.52-1 (52-B1) – Mineral insulation/Copper conductors and sheath/ Bare cable not exposed to touch (see note 2) Metallic sheath temperature: 105 °C/Reference ambient temperature: 30 °C .....	39
Table A.52-10 (52-C9) – Current-carrying capacities in amperes for installation methods E, F and G of table A.52-1 (52-B1) – PVC insulation/Copper conductors Conductor temperature: 70 °C/Reference ambient temperature: 30 °C.....	40
Table A.52-11 (52-C10) – Current-carrying capacities in amperes for installation methods E, F and G of table A.52-1 (52-B1) – PVC insulation/Aluminium conductors Conductor temperature: 70 °C/Reference ambient temperature: 30 °C.....	41
Table A.52-12 (52-C11) – Current-carrying capacities in amperes for installation methods E, F and G of table A.52-1 (52-B1) – XLPE or EPR insulation/Copper conductors – Conductor temperature: 90 °C/Reference ambient temperature: 30 °C.....	42
Table A.52-13 (52-C12) – Current-carrying capacities in amperes for installation methods E, F and G of table A.52-1 (52-B1) – XLPE or EPR insulation/Aluminium conductors Conductor temperature: 90 °C/Reference ambient temperature: 30 °C.....	43
Table A.52-14 (52-D1) – Correction factor for ambient air temperatures other than 30 °C to be applied to the current-carrying capacities for cables in the air .....	44

Table A.52-15 (52-D2) – Correction factors for ambient ground temperatures other than 20 °C to be applied to the current-carrying capacities for cables in ducts in the ground.....	45
Table A.52-16 (52-D3) – Correction factors for cables in buried ducts for soil thermal resistivities other than 2,5 K·m/W to be applied to the current-carrying capacities for reference method D .....	45
Table A.52-17 (52-E1) – Reduction factors for groups of more than one circuit or of more than one multi-core cable to be used with current carrying capacities of tables A.52-2 (52-C1) to A.52-13 (52-C12) .....	46
Table A.52-18 (52-E2) – Reduction factors for more than one circuit, cables laid directly in the ground – Installation method D in tables A.52-2 (52-C1) to A.52-5 (52-C4) – Single-core or multi-core cables.....	47
Table A.52-19 (52-E3) – Reduction factors for more than one circuit, cables laid in ducts in the ground – Installation method D in tables A.52-2 (52-C1) to A.52-5 (52-C4) .....	48
Table A.52-20 (52-E4) – Reduction factors for group of more than one multi-core cable to be applied to reference ratings for multi-core cables in free air – Method of installation E in tables A.52-8 (52-C7) to A.52-13 (52-C12).....	49
Table A.52-21 (52-E5) – Reduction factors for groups of more than one circuit of single-core cables (note 2) to be applied to reference rating for one circuit of single-core cables in free air – Method of installation F in tables A.52-8 (52-C7) to A.52-13 (52-C12).....	50
Table B.52-1 (A.52-1) – Current-carrying capacity in amperes .....	52
Table B.52-2 (A.52-2) – Current-carrying capacities (in amperes).....	53
Table B.52-3 (A.52-3) – Reduction factors for groups of several circuits or of several multi-core cables (to be used with current-carrying capacities of table B.52-1) (A.52-1) .....	54
Table C.52-1 (B.52-1) – Table of coefficients and exponents .....	56
Table D.52-1 (C.52-1) – Reduction factors for harmonic currents in four-core and five-core cables .....	59
Table E.1 – Relationship between re-structured and original parts .....	60
Table E.2 – Relationship between new and old clause numbering.....	62

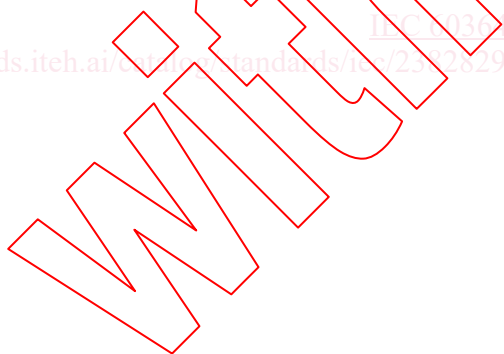

## INTERNATIONAL ELECTROTECHNICAL COMMISSION

**ELECTRICAL INSTALLATIONS OF BUILDINGS –****Part 5-52: Selection and erection of electrical equipment –  
Wiring systems**

## FOREWORD

- 1) The IEC (International Electrotechnical Commission) is a worldwide organization for standardization comprising all national electrotechnical committees (IEC National Committees). The object of the IEC is to promote international co-operation on all questions concerning standardization in the electrical and electronic fields. To this end and in addition to other activities, the IEC publishes International Standards. Their preparation is entrusted to technical committees; any IEC National Committee interested in the subject dealt with may participate in this preparatory work. International, governmental and non-governmental organizations liaising with the IEC also participate in this preparation. The IEC collaborates closely with the International Organization for Standardization (ISO) in accordance with conditions determined by agreement between the two organizations.
- 2) The formal decisions or agreements of the IEC on technical matters express, as nearly as possible, an international consensus of opinion on the relevant subjects since each technical committee has representation from all interested National Committees.
- 3) The documents produced have the form of recommendations for international use and are published in the form of standards, technical specifications, technical reports or guides and they are accepted by the National Committees in that sense.
- 4) In order to promote international unification, IEC National Committees undertake to apply IEC International Standards transparently to the maximum extent possible in their national and regional standards. Any divergence between the IEC Standard and the corresponding national or regional standard shall be clearly indicated in the latter.
- 5) The IEC provides no marking procedure to indicate its approval and cannot be rendered responsible for any equipment declared to be in conformity with one of its standards.
- 6) Attention is drawn to the possibility that some of the elements of this International Standard may be the subject of patent rights. The IEC shall not be held responsible for identifying any or all such patent rights.

International Standard IEC 60364-5-52 has been prepared by IEC technical committee 64:  
Electrical installations and protection against electric shock.

The IEC 60364 series (parts 1 to 6) is currently being restructured, without any technical changes, into a more simple form (see annex E).

According to a unanimous decision by the Committee of Action (CA/1720/RV (2000-03-21)), the restructured parts of IEC 60364 have not been submitted to National Committees for approval.

The text of this second edition of IEC 60364-5-52 is compiled from and replaces

- part 5-52, first edition (1993) and its amendment 1 (1997);
- part 5-523, second edition (1999).

This publication has been drafted, as close as possible, in accordance with the ISO/IEC Directives, Part 3.

Annex A forms an integral part of this standard.

Annexes B, C, D and E are for information only.

The committee has decided that the contents of this publication will remain unchanged until 2005. At this date, the publication will be

- reconfirmed;
- withdrawn;
- replaced by a revised edition, or
- amended.

## ELECTRICAL INSTALLATIONS OF BUILDINGS –

### Part 5-52: Selection and erection of electrical equipment – Wiring systems

#### 520 Introduction

##### 520.1 Scope

Part 5-52 of IEC 60364 deals with the selection and erection of wiring systems.

NOTE This standard also applies in general to protective conductors, while IEC 60364-5-54 contains further requirements for those conductors.

##### 520.2 Normative references

The following normative documents contain provisions which, through reference in this text, constitute provisions of this part of IEC 60364. For dated references, subsequent amendments to, or revisions of, any of these publications do not apply. However, parties to agreements based on this part of IEC 60364 are encouraged to investigate the possibility of applying the most recent editions of the normative documents indicated below. For undated references, the latest edition of the normative document referred to applies. Members of IEC and ISO maintain registers of currently valid International Standards.

IEC 60228: 1978, *Conductors of insulated cables*

IEC 60287-1-1:1994, *Electric cables – Calculation of the current rating – Part 1: Current rating equations (100 % load factor) and calculation of losses – Section 1: General*

IEC 60287-2-1:1994, *Electric cables – Calculation of the current rating – Part 2: Thermal resistance – Section 1: Calculation of thermal resistance*

IEC 60287-3-1:1995, *Electric cables – Calculation of the current rating – Part 3: Sections on operating conditions – Section 1: Reference operating conditions and selection of cable type*<sup>1)</sup>

IEC 60332-1:1993, *Tests on electric cables under fire conditions – Part 1: Test on a single vertical insulated wire or cable*

IEC 60332-3-24:2000, *Tests on electric cables under fire conditions – Part 3-24: Test for vertical flame spread of vertically-mounted bunched wire or cables – Category C*

IEC 60439-2:2000, *Low-voltage switchgear and controlgear assemblies – Part 2: Particular requirements for busbar trunking systems (busways)*

IEC 60529:1989, *Degrees of protection provided by enclosures (IP Code)*<sup>2)</sup>

IEC 60614 (all parts), *Specification for conduits for electrical installations*

IEC 61200-52:1993, *Electrical installation guide – Part 52: Selection and erection of electrical equipment – Wiring systems*

ISO 834 (all parts) *Fire-resistance tests – Elements of building construction*

<sup>1)</sup> A consolidated edition 1.1 exists (1999) that includes IEC 60287-3-1 (1995) and its amendment 1 (1999).

<sup>2)</sup> A consolidated edition 2.1 exists (2001) that includes IEC 60529 (1989) and its amendment 1 (1999).



### 520.3 General

Consideration shall be given to the application of the fundamental principles of IEC 60364-1 as it applies to cables and conductors, to their termination and/or jointing, to their associated supports or suspensions and their enclosures or methods of protection against external influences.

## 521 Types of wiring systems

**521.1** The method of installation of a wiring system in relation to the type of conductor or cable used shall be in accordance with table 52-1, provided the external influences are covered by the requirements of the relevant product standards.

**521.2** The method of installation of a wiring system in relation to the situation concerned shall be in accordance with table 52-2.

**521.3** Examples of wiring systems together with reference to the appropriate table of current-carrying capacity are shown in table 52-3.

NOTE 1 Other types of wiring systems, not covered in this standard, may be used provided they comply with the general rules of this standard.

NOTE 2 Table 52-3 gives the reference method of installation where it is considered that the same current-carrying capacities can safely be used. It is not implied that all these items are necessarily recognized in national rules of all countries.

### 521.4 Busbar trunking systems

Busbar trunking systems shall comply with IEC 60439-2 and shall be installed in accordance with the manufacturer's instructions. The installation shall be in accordance with the requirements of clauses 522 (with the exception of 522.1.1, 522.3.3, 522.8.7, 522.8.8 and 522.8.9), 525, 526, 527 and 528.

### 521.5 AC circuits

Conductors of a.c. circuits installed in ferromagnetic enclosures shall be arranged so that all conductors of each circuit are contained in the same enclosure.

NOTE If this condition is not fulfilled, overheating and excessive voltage drop may occur due to inductive effects.

**Table 52-1 (52F) – Selection of wiring systems**

Conductors and cables		Method of installation							
		Without fixings	Clipped direct	Conduit	Cable trunking (including skirting trunking, flush floor trunking)	Cable ducting	Cable ladder Cable tray Cable brackets	On insulators	Support wire
Bare conductors		–	–	–	–	–	–	+	–
Insulated conductors		–	–	+	+	+	–	+	–
Sheathed cables (including armoured and mineral insulated)	Multi-core	+	+	+	+	+	+	0	+
	Single-core	0	+	+	+	+	+	0	+

+ Permitted.  
 – Not permitted.  
 0 Not applicable, or not normally used in practice.

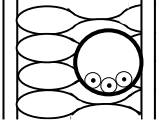
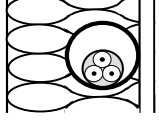
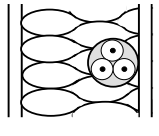
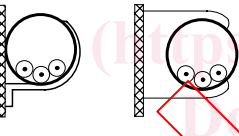
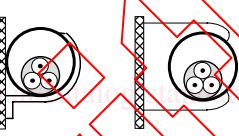
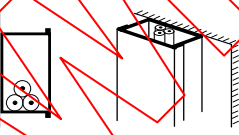

**Table 52-2 (52G) – Erection of wiring systems**

Situations	Method of installation							
	Without fixings	With fixings	Conduit	Cable trunking (including skirting trunking, flush floor trunking)	Cable ducting	Cable ladder, cable tray, cable brackets	On insulators	Support wire
Building voids	40, 46, 15, 16	0	15, 16, 41, 42	–	43	30, 31, 32, 33, 34	–	–
Cable channel	56	56	54, 55	0	44, 45	30, 31, 32, 33, 34	–	–
Buried in ground	72, 73	0	70, 71	–	70, 71	0	–	–
Embedded in structure	57, 58	3	1, 2, 59, 60	50, 51, 52, 53	44, 45	0	–	–
Surface mounted	–	20, 21, 22, 23	4, 5	6, 7, 8, 9, 12, 13, 14	6, 7, 8, 9	30, 31, 32, 33, 34	36	–
Overhead	–	–	0	10, 11	–	30, 31, 32, 33, 34	36	35
Immersed	80	80	0	–	0	0	–	–

The number in each box indicates the item number in table 52-3.  
 – Not permitted.  
 0 Not applicable or not normally used in practice.

**Table 52-3 (52H) – Examples of methods of installation providing instructions for obtaining current-carrying capacity**

NOTE The illustrations are not intended to depict actual product or installation practices but are indicative of the method described.

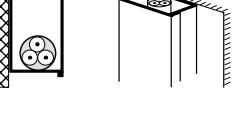
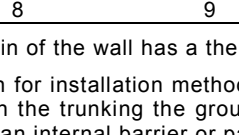
Item No.	Methods of installation	Description	Reference method of installation to be used to obtain current-carrying capacity (see annex A)
1	 <p>Room</p>	Insulated conductors or single-core cables in conduit in a thermally insulated wall <sup>a</sup>	A1
2	 <p>Room</p>	Multi-core cables in conduit in a thermally insulated wall <sup>a</sup>	A2
3	 <p>Room</p>	Multi-core cable direct in a thermally insulated wall <sup>a</sup>	A1
4		Insulated conductors or single-core cables in conduit on a wooden, or masonry wall or spaced less than 0,3 × conduit diameter from it	B1
5		Multi-core cable in conduit on a wooden, or masonry wall or spaced less than 0,3 × conduit diameter from it	B2
6	 <p>6</p>	Insulated conductors or single-core cables in cable trunking on a wooden wall – run horizontally <sup>b</sup> – run vertically <sup>b, c</sup>	B1
7	 <p>7</p>		
8	 <p>8</p>	Multi-core cable in cable trunking on a wooden wall – run horizontally <sup>b</sup> – run vertically <sup>b, c</sup>	Under consideration <sup>d</sup>
9	 <p>9</p>		







<sup>a</sup> The inner skin of the wall has a thermal conductance of not less than 10 W/m<sup>2</sup> · K.

<sup>b</sup> Values given for installation methods B1 and B2 in annex A are for a single circuit. Where there is more than one circuit in the trunking the group reduction factor given in table A.52-17 is applicable, irrespective of the presence of an internal barrier or partition.

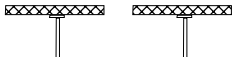
<sup>c</sup> Care shall be taken where the cable runs vertically and ventilation is restricted. The ambient temperature at the top of the vertical section can be increased considerably. The matter is under consideration.

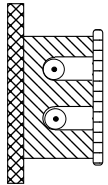
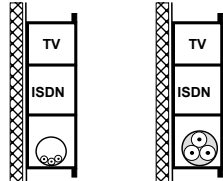
<sup>d</sup> Values for reference method B2 may be used.

Table 52-3 (continued)

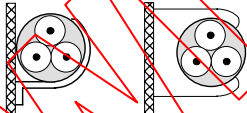
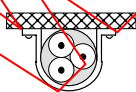
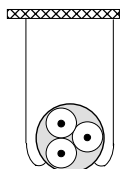

Item No.	Methods of installation	Description	Reference method of installation to be used to obtain current-carrying capacity (see annex A)
10		Insulated conductors or single-core cable in suspended cable trunking <sup>a</sup>	B1
11		Multi-core cable in suspended cable trunking <sup>a</sup>	B2
12		Insulated conductors or single-core cable run in mouldings <sup>b</sup>	A1
13		Insulated conductors or single-core cables in skirting trunking	B1
14		Multi-core cable in skirting trunking	B2
15		Insulated conductors in conduit or single-core or multi-core cable in architrave <sup>c</sup>	A1
16		Insulated conductors in conduit or single-core or multi-core cable in window frames <sup>c</sup>	A1
20		Single-core or multi-core cables: – fixed on, or spaced less than 0,3 × cable diameter from a wooden wall	C
21		– fixed directly under a wooden ceiling	C, with item 3 of table A.52-17
22		– spaced from a ceiling	Under consideration

<sup>a</sup> Values given for installation methods B1 and B2 in annex A are for a single circuit. Where there is more than one circuit in the trunking the group reduction factor given in table A.52-17 is applicable, irrespective of the presence of an internal barrier or partition.

<sup>b</sup> The thermal resistivity of the enclosure is assumed to be poor because of the material of construction and possible air spaces. Where the construction is thermally equivalent to methods of installation 6 or 7, reference method B1 may be used.

<sup>c</sup> The thermal resistivity of the enclosure is assumed to be poor because of the material of construction and possible air spaces. Where the construction is thermally equivalent to methods of installation 6, 7, 8, or 9, reference methods B1 or B2 may be used.

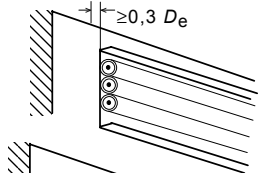
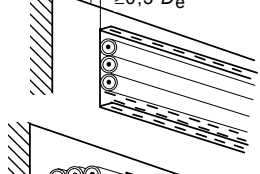
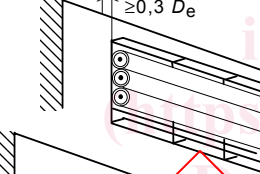
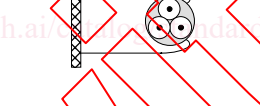
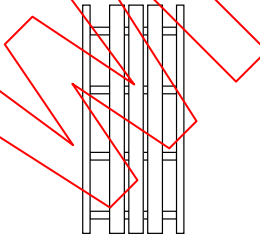
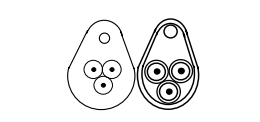
Table 52-3 (continued)



Item No.	Methods of installation	Description	Reference method of installation to be used to obtain current-carrying capacity (see annex A)
30		On unperforated tray <sup>c</sup>	C with item 2 of table A.52-17 <sup>a</sup>
31		On perforated tray <sup>c</sup>	E or F with item 4 of table A.52-17 <sup>a, b</sup>
32		On brackets or on a wire mesh <sup>c</sup>	E or F
33		Spaced more than 0,3 times cable diameter from a wall	E or F with item 4 or 5 of table A.52-17 or method G <sup>a, b</sup>
34		On ladder	E or F
35		Single-core or multi-core cable suspended from or incorporating a support wire	E or F
36		Bare or insulated conductors on insulators	G

<sup>a</sup> For certain applications it may be more appropriate to use specific factors, for example tables A.52-20 and A.52-21 (see A.52.4.2 of annex A).

<sup>b</sup> Care shall be taken where the cable runs vertically and ventilation is restricted. The ambient temperature at the top of the vertical section can be increased considerably. The matter is under consideration.

<sup>c</sup>  $D_e$  = the external diameter of a multi-core cable:  
 - 2,2 x the cable diameter when three single core cables are bound in trefoil, or  
 - 3 x the cable diameter when three single core cables are laid in flat formation.

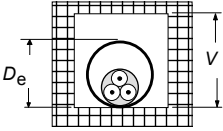
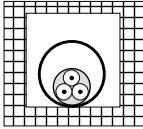
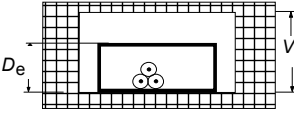
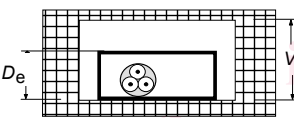
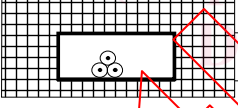
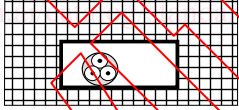
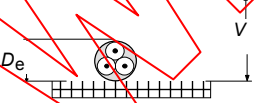
Table 52-3 (continued)

Item No.	Methods of installation	Description	Reference method of installation to be used to obtain current-carrying capacity (see annex A)
40		Single-core or multi-core cable in a building void <sup>a, 2</sup>	$1,5 D_e \leq V < 20 D_e$ B2 $V \geq 20 D_e$ B1
42		Single-core or multi-core cable in conduit in a building void <sup>d</sup>	Under consideration
24		Insulated conductors in cable ducting in a building void <sup>a, c, d</sup>	$1,5 D_e \leq V < 20 D_e$ B2 $V \geq 20 D_e$ B1
43		Single-core or multi-core cable in cable ducting in a building void <sup>d</sup>	Under consideration
44		Insulated conductors in cable ducting in masonry having a thermal resistivity not greater than 2 K·m/W <sup>a, b, d</sup>	$1,5 D_e \leq V < 5 D_e$ B2 $5 D_e \leq V < 50 D_e$ B1
45		Single-core or multi-core cable in cable ducting in masonry having a thermal resistivity not greater than 2 K·m/W <sup>d</sup>	Under consideration
46		Single-core or multi-core cable: – in a ceiling void – in a suspended floor <sup>a, b</sup>	$1,5 D_e \leq V < 5 D_e$ B2 $5 D_e \leq V < 50 D_e$ B1
50		Insulated conductors or single-core cable in flush cable trunking in the floor	B1
51		Multi-core cable in flush cable trunking in the floor	B2

<sup>a</sup> V = the smaller dimension or diameter of a masonry duct or void, or the vertical depth of a rectangular duct, floor or ceiling void.

<sup>b</sup>  $D_e$  = the external diameter of a multi-core cable:  
 –  $2,2 \times$  the cable diameter when three single core cables are bound in trefoil, or  
 –  $3 \times$  the cable diameter when three single core cables are laid in flat formation.

<sup>c</sup>  $D_e$  = external diameter of conduit or vertical depth of cable ducting.

<sup>d</sup> Care shall be taken where the cable runs vertically and ventilation is restricted. The ambient temperature at the top of the vertical section can be increased considerably. The matter is under consideration.