

INTERNATIONAL STANDARD

NORME INTERNATIONALE

High-voltage switchgear and controlgear –
Part 110: Inductive load switching

Appareillage à haute tension –
Partie 110: Manœuvre de charges inductives ⁰²³

<https://standards.iteh.ai/catalog/standards/sist/8fd2ad60-45b9-4b3d-bd33-00200e24ffd7/iec-62271-110-2023>

ITEH STANDARD PREVIEW
(standards.iteh.ai)



THIS PUBLICATION IS COPYRIGHT PROTECTED

Copyright © 2023 IEC, Geneva, Switzerland

All rights reserved. Unless otherwise specified, no part of this publication may be reproduced or utilized in any form or by any means, electronic or mechanical, including photocopying and microfilm, without permission in writing from either IEC or IEC's member National Committee in the country of the requester. If you have any questions about IEC copyright or have an enquiry about obtaining additional rights to this publication, please contact the address below or your local IEC member National Committee for further information.

Droits de reproduction réservés. Sauf indication contraire, aucune partie de cette publication ne peut être reproduite ni utilisée sous quelque forme que ce soit et par aucun procédé, électronique ou mécanique, y compris la photocopie et les microfilms, sans l'accord écrit de l'IEC ou du Comité national de l'IEC du pays du demandeur. Si vous avez des questions sur le copyright de l'IEC ou si vous désirez obtenir des droits supplémentaires sur cette publication, utilisez les coordonnées ci-après ou contactez le Comité national de l'IEC de votre pays de résidence.

IEC Secretariat
3, rue de Varembe
CH-1211 Geneva 20
Switzerland

Tel.: +41 22 919 02 11
info@iec.ch
www.iec.ch

About the IEC

The International Electrotechnical Commission (IEC) is the leading global organization that prepares and publishes International Standards for all electrical, electronic and related technologies.

About IEC publications

The technical content of IEC publications is kept under constant review by the IEC. Please make sure that you have the latest edition, a corrigendum or an amendment might have been published.

IEC publications search - webstore.iec.ch/advsearchform

The advanced search enables to find IEC publications by a variety of criteria (reference number, text, technical committee, ...). It also gives information on projects, replaced and withdrawn publications.

IEC Just Published - webstore.iec.ch/justpublished

Stay up to date on all new IEC publications. Just Published details all new publications released. Available online and once a month by email.

IEC Customer Service Centre - webstore.iec.ch/csc

If you wish to give us your feedback on this publication or need further assistance, please contact the Customer Service Centre: sales@iec.ch.

IEC Products & Services Portal - products.iec.ch

Discover our powerful search engine and read freely all the publications previews. With a subscription you will always have access to up to date content tailored to your needs.

Electropedia - www.electropedia.org

The world's leading online dictionary on electrotechnology, containing more than 22 300 terminological entries in English and French, with equivalent terms in 19 additional languages. Also known as the International Electrotechnical Vocabulary (IEV) online.

A propos de l'IEC

La Commission Electrotechnique Internationale (IEC) est la première organisation mondiale qui élabore et publie des Normes internationales pour tout ce qui a trait à l'électricité, à l'électronique et aux technologies apparentées.

A propos des publications IEC

Le contenu technique des publications IEC est constamment revu. Veuillez vous assurer que vous possédez l'édition la plus récente, un corrigendum ou amendement peut avoir été publié.

Recherche de publications IEC -

webstore.iec.ch/advsearchform

La recherche avancée permet de trouver des publications IEC en utilisant différents critères (numéro de référence, texte, comité d'études, ...). Elle donne aussi des informations sur les projets et les publications remplacées ou retirées.

IEC Just Published - webstore.iec.ch/justpublished

Restez informé sur les nouvelles publications IEC. Just Published détaille les nouvelles publications parues. Disponible en ligne et une fois par mois par email.

Service Clients - webstore.iec.ch/csc

Si vous désirez nous donner des commentaires sur cette publication ou si vous avez des questions contactez-nous: sales@iec.ch.

IEC Products & Services Portal - products.iec.ch

Découvrez notre puissant moteur de recherche et consultez gratuitement tous les aperçus des publications. Avec un abonnement, vous aurez toujours accès à un contenu à jour adapté à vos besoins.

Electropedia - www.electropedia.org

Le premier dictionnaire d'électrotechnologie en ligne au monde, avec plus de 22 300 articles terminologiques en anglais et en français, ainsi que les termes équivalents dans 19 langues additionnelles. Egalement appelé Vocabulaire Electrotechnique International (IEV) en ligne.

INTERNATIONAL STANDARD

NORME INTERNATIONALE

**High-voltage switchgear and controlgear –
Part 110: Inductive load switching**

**Appareillage à haute tension –
Partie 110: Manœuvre de charges inductives**

<https://standards.iteh.ai/catalog/standards/sist/8fd2ad60-45b9-4b3d-bd33-00200e24fd7/iec-62271-110-2023>

INTERNATIONAL
ELECTROTECHNICAL
COMMISSION

COMMISSION
ELECTROTECHNIQUE
INTERNATIONALE

ICS 29.130.10

ISBN 978-2-8322-6649-6

**Warning! Make sure that you obtained this publication from an authorized distributor.
Attention! Veuillez vous assurer que vous avez obtenu cette publication via un distributeur agréé.**

CONTENTS

| | |
|--|----|
| FOREWORD..... | 4 |
| 1 Scope..... | 6 |
| 2 Normative references | 6 |
| 3 Terms and definitions | 7 |
| 4 Type tests | 8 |
| 4.1 General..... | 8 |
| 4.2 Miscellaneous provisions for inductive load switching tests | 8 |
| 4.3 High-voltage motor current switching tests | 9 |
| 4.3.1 Applicability | 9 |
| 4.3.2 General | 9 |
| 4.3.3 Characteristics of the supply circuits..... | 10 |
| 4.3.4 Characteristics of the load circuit..... | 11 |
| 4.3.5 Test voltage..... | 11 |
| 4.3.6 Test-duties | 12 |
| 4.3.7 Test measurements | 12 |
| 4.3.8 Behaviour and condition of switching device | 12 |
| 4.3.9 Test report..... | 13 |
| 4.4 Shunt reactor current switching tests | 14 |
| 4.4.1 Applicability | 14 |
| 4.4.2 General | 15 |
| 4.4.3 Test circuits | 15 |
| 4.4.4 Characteristics of the supply circuit | 18 |
| 4.4.5 Characteristics of the connecting leads..... | 18 |
| 4.4.6 Characteristics of the load circuits | 18 |
| 4.4.7 Earthing of the test circuit..... | 23 |
| 4.4.8 Test voltage..... | 23 |
| 4.4.9 Test-duties | 23 |
| Annex A (normative) Calculation of t_3 values..... | 27 |
| Bibliography..... | 29 |
| Figure 1 – Motor switching test circuit and summary of parameters..... | 10 |
| Figure 2 – Illustration of voltage transients at interruption of inductive current for first phase clearing in a three-phase non-effectively earthed circuit | 14 |
| Figure 3 – Reactor switching test circuit – Three-phase test circuit for in-service load circuit configurations 1 and 2 (Table 2) | 16 |
| Figure 4 – Reactor switching test circuit – Single-phase test circuit for in-service load circuit configurations 1, 2 and 4 (Table 2) | 17 |
| Figure 5 – Reactor switching test circuit – Three-phase test circuit for in-service load circuit configuration 3 (Table 2)..... | 18 |
| Figure 6 – Illustration of voltage transients at interruption of inductive current for a single-phase test | 26 |
| Table 1 – Test-duties at motor current switching tests..... | 12 |
| Table 2 – In-service load circuit configurations | 15 |

| | |
|--|----|
| Table 3 – Values of prospective transient recovery voltages – Rated voltages 12 kV to 170 kV for effectively and non-effectively earthed systems – Switching shunt reactors with isolated neutrals (Table 2: In-service load circuit configuration 1) | 19 |
| Table 4 – Values of prospective transient recovery voltages – Rated voltages 100 kV to 1 200 kV for effectively earthed systems – Switching shunt reactors with earthed neutrals (See Table 2: In-service load circuit configuration 2) | 20 |
| Table 5 – Values of prospective transient recovery voltages – Rated voltages 12 kV to 52 kV for effectively and non-effectively earthed systems – Switching shunt reactors with isolated neutrals (see Table 2: In-service load circuit configuration 3) | 21 |
| Table 6 – Values of prospective transient recovery voltages – Rated voltages 12 kV to 52 kV for effectively and non-effectively earthed systems – Switching shunt reactors with earthed neutrals (see Table 2: In-service load circuit configuration 4) | 22 |
| Table 7 – Load circuit 1 test currents | 22 |
| Table 8 – Load circuit 2 test currents | 23 |
| Table 9 – Test-duties for reactor current switching tests | 24 |

iTeh STANDARD PREVIEW
(standards.iteh.ai)

[IEC 62271-110:2023](https://standards.iteh.ai/catalog/standards/sist/8fd2ad60-45b9-4b3d-bd33-00200e24ffd7/iec-62271-110-2023)

<https://standards.iteh.ai/catalog/standards/sist/8fd2ad60-45b9-4b3d-bd33-00200e24ffd7/iec-62271-110-2023>

INTERNATIONAL ELECTROTECHNICAL COMMISSION

HIGH-VOLTAGE SWITCHGEAR AND CONTROLGEAR –

Part 110: Inductive load switching

FOREWORD

- 1) The International Electrotechnical Commission (IEC) is a worldwide organization for standardization comprising all national electrotechnical committees (IEC National Committees). The object of IEC is to promote international co-operation on all questions concerning standardization in the electrical and electronic fields. To this end and in addition to other activities, IEC publishes International Standards, Technical Specifications, Technical Reports, Publicly Available Specifications (PAS) and Guides (hereafter referred to as “IEC Publication(s)”). Their preparation is entrusted to technical committees; any IEC National Committee interested in the subject dealt with may participate in this preparatory work. International, governmental and non-governmental organizations liaising with the IEC also participate in this preparation. IEC collaborates closely with the International Organization for Standardization (ISO) in accordance with conditions determined by agreement between the two organizations.
- 2) The formal decisions or agreements of IEC on technical matters express, as nearly as possible, an international consensus of opinion on the relevant subjects since each technical committee has representation from all interested IEC National Committees.
- 3) IEC Publications have the form of recommendations for international use and are accepted by IEC National Committees in that sense. While all reasonable efforts are made to ensure that the technical content of IEC Publications is accurate, IEC cannot be held responsible for the way in which they are used or for any misinterpretation by any end user.
- 4) In order to promote international uniformity, IEC National Committees undertake to apply IEC Publications transparently to the maximum extent possible in their national and regional publications. Any divergence between any IEC Publication and the corresponding national or regional publication shall be clearly indicated in the latter.
- 5) IEC itself does not provide any attestation of conformity. Independent certification bodies provide conformity assessment services and, in some areas, access to IEC marks of conformity. IEC is not responsible for any services carried out by independent certification bodies.
- 6) All users should ensure that they have the latest edition of this publication.
- 7) No liability shall attach to IEC or its directors, employees, servants or agents including individual experts and members of its technical committees and IEC National Committees for any personal injury, property damage or other damage of any nature whatsoever, whether direct or indirect, or for costs (including legal fees) and expenses arising out of the publication, use of, or reliance upon, this IEC Publication or any other IEC Publications.
- 8) Attention is drawn to the Normative references cited in this publication. Use of the referenced publications is indispensable for the correct application of this publication.
- 9) Attention is drawn to the possibility that some of the elements of this IEC Publication may be the subject of patent rights. IEC shall not be held responsible for identifying any or all such patent rights.

IEC 62271-110 has been prepared by subcommittee 17A: Switching devices, of IEC technical committee 17: High-voltage switchgear and controlgear. It is an International Standard.

This fifth edition cancels and replaces the fourth edition published in 2017. This edition constitutes a technical revision.

This edition includes the following significant technical changes with respect to the previous edition:

- a) references to IEC 62271-100 and IEC 62271-106 have been updated to the latest editions.

The text of this document is based on the following documents:

| Draft | Report on voting |
|---------------|------------------|
| 17A/1368/FDIS | 17A/1376/RVD |

Full information on the voting for its approval can be found in the report on voting indicated in the above table.

The language used for the development of this International Standard is English.

This document was drafted in accordance with ISO/IEC Directives, Part 2, and developed in accordance with ISO/IEC Directives, Part 1 and ISO/IEC Directives, IEC Supplement, available at www.iec.ch/members_experts/refdocs. The main document types developed by IEC are described in greater detail at www.iec.ch/publications.

A list of all parts of the IEC 62271 series can be found, under the general title *High-voltage switchgear and controlgear*, on the IEC website.

The committee has decided that the contents of this document will remain unchanged until the stability date indicated on the IEC website under webstore.iec.ch in the data related to the specific document. At this date, the document will be

- reconfirmed,
- withdrawn,
- replaced by a revised edition, or
- amended.

[IEC 62271-110:2023](https://standards.iteh.ai/catalog/standards/sist/8fd2ad60-45b9-4b3d-bd33-00200e24ffd7/iec-62271-110-2023)

<https://standards.iteh.ai/catalog/standards/sist/8fd2ad60-45b9-4b3d-bd33-00200e24ffd7/iec-62271-110-2023>

HIGH-VOLTAGE SWITCHGEAR AND CONTROLGEAR –

Part 110: Inductive load switching

1 Scope

This part of IEC 62271 is applicable to AC switching devices designed for indoor or outdoor installation, for operation at frequencies of 50 Hz and 60 Hz on systems having voltages above 1 000 V and applied for inductive current switching. It is applicable to switching devices (including circuit-breakers in accordance with IEC 62271-100) that are used to switch high-voltage motor currents and shunt reactor currents and also to high-voltage contactors used to switch high-voltage motor currents as covered by IEC 62271-106.

Switching unloaded transformers, i.e. breaking transformer magnetizing current, is not considered in this document. The reasons for this are as follows:

- a) Owing to the non-linearity of the transformer core, it is not possible to correctly model the switching of transformer magnetizing current using linear components in a test laboratory. Tests conducted using an available transformer, such as a test transformer, will only be valid for the transformer tested and cannot be representative for other transformers.
- b) As detailed in IEC TR 62271-306, the characteristics of this duty are usually less severe than any other inductive current switching duty. Such a duty can produce severe overvoltages within the transformer winding(s) depending on the re-ignition behaviour of the switching device and transformer winding resonance frequencies.

NOTE 1 The switching of tertiary reactors from the high-voltage side of the transformer is not covered by this document.

NOTE 2 The switching of shunt reactors earthed through neutral reactors is not covered by this document. However, the application of test results according to this document, on the switching of neutral reactor earthed reactors (4-leg reactor scheme), is discussed in IEC TR 62271-306.

2 Normative references

The following documents are referred to in the text in such a way that some or all of their content constitutes requirements of this document. For dated references, only the edition cited applies. For undated references, the latest edition of the referenced document (including any amendments) applies.

IEC 60050-441, *International Electrotechnical Vocabulary (IEV) – Part 441: Switchgear, controlgear and fuses*, available at www.electropedia.org

IEC 62271-1:2017, *High-voltage switchgear and controlgear – Part 1: Common specifications for alternating current switchgear and controlgear*
IEC 62271-1:2017/AMD1:2021

IEC 62271-100:2021, *High-voltage switchgear and controlgear – Part 100: Alternating-current circuit-breakers*

IEC 62271-106:2021, *High-voltage switchgear and controlgear – Part 106: Alternating current contactors, contactor-based controllers and motor-starters*

3 Terms and definitions

For the purposes of this document, the terms and definitions given in IEC 60050-441, IEC 62271-1 and the following apply.

ISO and IEC maintain terminology databases for use in standardization at the following addresses:

- IEC Electropedia: available at <https://www.electropedia.org/>
- ISO Online browsing platform: available at <https://www.iso.org/obp>

3.1

inductive current

power-frequency current drawn by an inductive circuit having a power factor 0,5 or less

3.2

current chopping

abrupt current interruption in a switching device at a point-on-wave other than the natural power-frequency current zero

3.3

virtual current chopping

current chopping in one of the three phases in a three-phase circuit originated by transients in another phase of the circuit

3.4

suppression peak

first peak of the transient voltage to earth on the load side of the switching device following current interruption

Note 1 to entry: Suppression peak is not necessarily the absolute maximum of the transient recovery voltage. Previous breakdowns can have appeared at higher voltage values.

3.5

recovery peak

maximum value of the voltage across the switching device occurring when the polarity of the recovery voltage is equal to the polarity of the power-frequency voltage

Note 1 to entry: Recovery peak is not necessarily the absolute maximum of the transient recovery voltage. Previous breakdowns can have appeared at higher voltage values.

3.6

re-ignition

resumption of current between the contacts of a mechanical switching device during a breaking operation with an interval of zero current of less than a quarter cycle of power frequency

Note 1 to entry: In the case of inductive load switching the initiation of the re-ignition is a high-frequency event, which can be of a single or multiple nature and can in some cases be interrupted without power-frequency follow current.

3.7

re-ignition-free arcing time window

period of arc duration during a breaking operation during which the contacts of a mechanical switching device reach sufficient distance to exclude re-ignition

4 Type tests

4.1 General

Circuit-breakers according to IEC 62271-100 and contactors according to IEC 62271-106 do not have dedicated inductive load switching ratings. However, switching devices applied for this purpose shall meet the requirements of this document.

For shunt reactor switching test of circuit-breakers, the rated insulation level values stated in Tables 1, 2, 3 and 4 of IEC 62271-1:2017 are applicable with the exception of combined voltage tests across the isolating distance (columns (6) and (8) in Table 3 and column (5) in Table 4 of IEC 62271-1:2017).

The type tests are in addition to those specified in the relevant product standard, with the exception of short-line faults, out-of-phase switching and capacitive current switching.

NOTE 1 The reason for this exception is the source-less nature of the shunt reactor load circuit.

NOTE 2 In some cases (high chopping overvoltage levels, or where a neutral reactor is present or in cases of shunt reactors with isolated neutral), an appropriate insulation level that is higher than the rated values stated above can be necessary.

Inductive load switching tests performed for a given current level and type of application can be considered valid for another current rating and same type of application as detailed below:

- a) for shunt reactor switching at rated voltages of 52 kV and above, tests at a particular current level shall be considered valid for applications with a higher current level up to 150 % of the tested current value;
- b) for shunt reactor switching at rated voltages below 52 kV, type testing is required;
- c) for high-voltage motor switching, type testing for stalled motor currents at 100 A and 300 A is considered to cover stalled motor currents in the range 100 A to 300 A and up to the current associated with the short-circuit current of test-duty T10 according to 7.107.2 of IEC 62271-100:2021 for circuit-breakers and up to the rated operational current for contactors.

With respect to a) the purpose of type testing is also to determine a re-ignition-free arcing time window for controlled switching purposes (see IEC TR 62271-302) and caution should be exercised when considering applications at higher currents than the tested values since the re-ignition-free arcing window can increase at higher current.

Annex B of IEC 62271-100:2021 can be used with respect to tolerances on test quantities.

4.2 Miscellaneous provisions for inductive load switching tests

Subclause 7.102 of IEC 62271-100:2021 is applicable with the following addition:

High-voltage motor current and shunt reactor switching tests shall be performed at rated auxiliary and control voltage or, where necessary, at maximum auxiliary and control voltage to facilitate consistent control of the opening and closing operation according to 7.102.3.1 of IEC 62271-100:2021.

For gas filled switching devices (including vacuum switching devices using gaseous media for insulation), tests shall be performed at the rated functional pressure for interruption and insulation, except for test-duty 4, where the pressure shall be the minimum functional pressure for interruption and insulation.

4.3 High-voltage motor current switching tests

4.3.1 Applicability

Subclause 4.3 is applicable to three-phase alternating current switching devices having rated voltages above 1 kV and up to 17,5 kV, which are used for switching high-voltage motors. Tests can be carried out at 50 Hz with a relative tolerance of $\pm 10\%$ or 60 Hz with a relative tolerance of $\pm 10\%$, both frequencies being considered equivalent.

Motor switching tests are applicable to all three-pole switching devices having rated voltages equal to or less than 17,5 kV, which can be used for the switching of three-phase asynchronous squirrel-cage or slip-ring motors. The switching device can be of a higher rated voltage than the motor when connected to the motor through a stepdown transformer. However, the usual application is a direct cable connection between switching device and motor. When tests are required, they shall be made in accordance with 4.3.2 to 4.3.9.

When overvoltage limitation devices are mandatory for the tested equipment, the voltage limiting devices can be included in the test circuit provided that the devices are an intrinsic part of the equipment under test.

No limits to the overvoltages are given as the overvoltages are only relevant to the specific application. Overvoltages between phases can be as significant as phase-to-earth overvoltages.

4.3.2 General

The switching tests can be either field tests or laboratory tests. As regards overvoltages, the switching of the current of a starting or stalled motor is usually the more severe operation.

Due to the non-linear behaviour of the motor iron core, it is not possible to exactly model the switching of motor current using linear components in a test station. Tests using linear components to simulate the motors can be considered to be more conservative than switching actual motors.

For laboratory tests a standardized circuit simulating the stalled condition of a motor is specified (refer to Figure 1). The parameters of this test circuit have been chosen to represent a relatively severe case with respect to overvoltages and will cover the majority of service applications.

The laboratory tests are performed to prove the ability of a switching device to switch motors and to establish its behaviour with respect to switching overvoltages, re-ignitions and current chopping. These characteristics can serve as a basis for estimates of the switching device's performance in other motor circuits. Tests performed with the test currents defined in 4.3.3 and 4.3.4 demonstrate the capability of the switching device to switch high-voltage motors up to its rated interrupting current.

For field tests, actual circuits are used with a supply system on the source side and a cable and motor on the load side. There can be a transformer between the switching device and motor. However, the results of such field tests are only valid for switching devices working in circuits similar to those during the tests.

The apparatus under test includes the switching device with overvoltage protection devices if they are normally fitted.

NOTE 1 Overvoltages can be produced when switching running motors. This condition is not represented by the substitute circuit and is generally considered to be less severe than the stalled motor case.

NOTE 2 The starting period switching of a slip-ring motor is generally less severe due to the effect of the starting resistor.

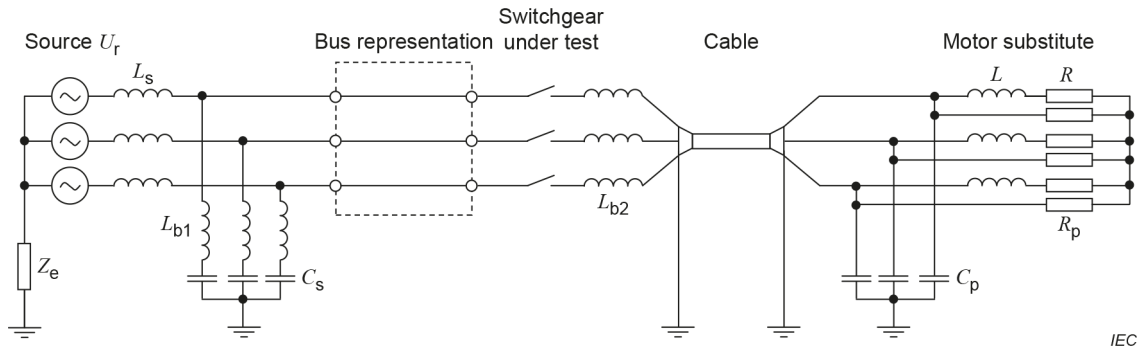

Key

| | | |
|--------------------|--|--|
| U_r | rated voltage | |
| Z_e | earthing impedance | impedance high enough to limit the phase-to-earth fault current to less than the test current (can be infinite) |
| L_s | source side inductance | $\omega L_s \leq 0,1 \omega L$, but prospective short-circuit current \leq the rated short-circuit current of the tested switching device |
| C_s | supply side capacitance | 0,03 μ F to 0,05 μ F for supply circuit A 1,5 μ F to 2 μ F for supply circuit B |
| L_{b1} | inductance of capacitors and connections | $\leq 2 \mu$ H |
| Bus representation | | 5 m to 7 m in length spaced appropriate to the rated voltage |
| L_{b2} | inductance of connections | $\leq 5 \mu$ H |
| Cable | | 100 m \pm 10 m, screened, surge impedance 30 Ω to 50 Ω |
| L | motor substitute inductance | load circuit 1: 100 A \pm 10 A load circuit 2: 300 A \pm 30 A |
| R | motor substitute resistance | $\cos \varphi \leq 0,2$ |
| C_p | motor substitute parallel capacitance | frequency 10 kHz to 15 kHz |
| R_p | motor substitute parallel resistance | amplitude factor 1,6 to 1,8 |

Figure 1 – Motor switching test circuit and summary of parameters

4.3.3 Characteristics of the supply circuits

4.3.3.1 General

A three-phase supply circuit shall be used. The tests shall be performed using two different supply circuits A and B as specified in 4.3.3.2 and 4.3.3.3, respectively. Supply circuit A represents the case of a motor connected directly to a transformer. Supply circuit B represents the case where parallel cables are applied on the supply side.

4.3.3.2 Supply circuit A

The three-phase supply can be earthed through a high ohmic impedance so that the supply voltage is defined with respect to earth. The impedance value shall be high enough to limit a prospective line-to-earth fault current to a value below the test current.

The source inductance L_s shall not be lower than that corresponding to the rated short-circuit breaking current of the tested switching device. Its impedance shall also be not higher than 0,1 times the impedance of the inductance in the load circuit (see 4.3.4).

The supply side capacitance C_s is represented by three capacitors connected in earthed star. Their value, including the natural capacitance of the circuit shall be $0,04 \mu\text{F} \pm 0,01 \mu\text{F}$. The inductance L_{b1} of the capacitors and connections shall not exceed $2 \mu\text{H}$.

The busbar inductance is represented by three bars forming a busbar each $6 \text{ m} \pm 1 \text{ m}$ in length and spaced at a distance appropriate to the rated voltage.

4.3.3.3 Supply circuit B

As supply circuit A with the value of the supply side capacitance increased to $1,75 \mu\text{F} \pm 0,25 \mu\text{F}$.

4.3.4 Characteristics of the load circuit

4.3.4.1 General

A three-phase load circuit shall be used. The motor substitute circuit is connected to the switching device under test by $100 \text{ m} \pm 10 \text{ m}$ of screened cable. It is recommended that the cable be connected directly to the terminals of the motor or substitute circuit.

The inductance of any intermediate connection should not exceed $3 \mu\text{H}$. The shield of the cable shall be earthed at both ends as shown in Figure 1. The tests shall be performed using two different motor substitute circuits as specified in 4.3.4.2 and 4.3.4.3. The inductance L_{b2} of the connections between the switching device and cable shall not exceed $5 \mu\text{H}$.

NOTE The use of a three-phase test circuit allows the possibility of virtual current chopping.

4.3.4.2 Motor substitute circuit 1

Series-connected resistance and inductance shall be arranged to obtain a current of $100 \text{ A} \pm 10 \text{ A}$ at a power factor less than 0,2 lagging. The star point shall not be connected to earth. Resistance R_p shall be connected in parallel with each phase impedance and capacitance C_p between each phase and earth so that the motor substitute circuit has a natural frequency of $12,5 \text{ kHz} \pm 2,5 \text{ kHz}$ and an amplitude factor of $1,7 \pm 0,1$ measured in each phase with the other two phases connected to earth. The prospective transient recovery voltages values shall be determined in accordance with Annex E of IEC 62271-100:2021. A transformer can be introduced at the load end of the cable. This shall be considered as part of the motor substitute circuit.

4.3.4.3 Motor substitute circuit 2

As motor substitute circuit 1, but with the series resistance and inductance reduced to obtain a current of $300 \text{ A} \pm 30 \text{ A}$ at a power factor less than 0,2 lagging. The prospective transient recovery voltage shall be as specified for motor substitute circuit 1.

4.3.5 Test voltage

a) The average value of the applied voltages shall be not less than the rated voltage U_r divided by $\sqrt{3}$ and shall not exceed this value by more than 10 % without the consent of the manufacturer.

The differences between the average value and the applied voltages of each pole shall not exceed 5 %.

The rated voltage U_r is that of the switching device when using the substitute circuit, but is that of the motor when an actual motor is used.

- b) The power-frequency recovery voltage of the test circuit can be stated as a percentage of the power-frequency recovery voltage specified below. It shall not be less than 95 % of the specified value and shall be maintained in accordance with 7.103.4 of IEC 62271-100:2021.

The average value of the power-frequency recovery voltages shall not be less than the rated voltage U_r of the switching device divided by $\sqrt{3}$.

The power-frequency recovery voltage of any pole should not deviate by more than 20 % from the average value at the end of the time for which it is maintained.

The power-frequency recovery voltage shall be measured between terminals of a pole in each phase of the test circuit. Its RMS value shall be determined on the oscillogram within the time interval of one half cycle and one cycle of test frequency after final arc extinction, as indicated in Figure 29 of IEC 62271-100:2021. The vertical distance (V_1 , V_2 and V_3 respectively) between the peak of the second half-wave and the straight line drawn between the respective peaks of the preceding and succeeding half-waves shall be measured, and this, when divided by $2\sqrt{2}$ and multiplied by the appropriate calibration factor, gives the RMS value of the recorded power-frequency recovery voltage.

4.3.6 Test-duties

The motor current switching tests shall consist of four test-duties as specified in Table 1.

Table 1 – Test-duties at motor current switching tests

| Test-duty | Supply circuit | Motor substitute circuit |
|-----------|----------------|--------------------------|
| 1 | A | 1 |
| 2 | A | 2 |
| 3 | B | 1 |
| 4 | B | 2 |

<https://standards.iteh.ai/catalog/standards/sist/8fd2ad60-45b9-4b3d-bd33-00200e24fd7/iec-62271-110-2023>

The number of tests for each test-duty shall be 20 tests with the initiation of the closing and tripping impulses distributed at intervals of approximately 9 electrical degrees.

The above tests shall be make-break tests or separate making and breaking tests except that when using an actual motor they shall only be make-break tests. When tests are made using the motor substitute circuit, the contacts of the switching device shall not be separated until any DC component has become less than 20 %. When switching an actual motor, a make-break time of 200 ms is recommended.

4.3.7 Test measurements

At least the following quantities shall be recorded by oscillograph or other suitable recording techniques with bandwidth and time resolution high enough to measure the following:

- power-frequency voltage;
- power-frequency current;
- phase-to-earth voltage, at the motor or motor substitute circuit terminals, in all three phases.

4.3.8 Behaviour and condition of switching device

The criteria for successful testing of a circuit-breaker are as follows:

- a) the behaviour of the circuit-breaker during the motor switching tests fulfils the conditions given in 7.102.8 of IEC 62271-100:2021 as applicable;
- b) a voltage test as condition check shall be performed in accordance with 7.2.12 of IEC 62271-100:2021;
- c) all re-ignitions shall take place between the arcing contacts.

The criteria for successful testing of contactors are listed in 7.103.9 of IEC 62271-106:2021.

4.3.9 Test report

In addition to the requirements of Annex C of IEC 62271-100:2021, the test report shall include a thorough description of the circuit, including the following details:

- a) main dimensions and characteristics of the bus and connections to the switching device;
- b) the characteristics of the cable:
 - 1) length;
 - 2) rated values;
 - 3) type;
 - 4) main insulation dielectric – cross-linked polyethylene (XLPE), paper/oil, etc.;
 - 5) earthing;
 - 6) capacitances;
 - 7) surge impedance.
- c) the parameters of the substitute motor circuit:
 - 1) natural frequency;
 - 2) amplitude factor;
 - 3) current;
 - 4) power factor.
- d) or details of the actual motor:
 - 1) type and rating;
 - 2) rated voltage;
 - 3) winding connection;
 - 4) rated motor current;
 - 5) starting current and power factor.
- e) overvoltage characteristics.

The following characteristics of the voltages at the motor or motor substitute circuit terminals at each test (Figure 2) shall be evaluated:

- u_p : maximum overvoltage;
- u_{ma} : suppression peak overvoltage;
- u_{mr} : load side voltage peak to earth;
- u_s : maximum peak-to-peak voltage excursion at re-ignition and/or restrike.

When overvoltages occur which can be hazardous for a specific application, or where switching device characteristics are required, a more comprehensive test programme will be required which is beyond the scope of this document.