



Designation: ~~F1912~~—~~19~~ F1912 – 21

## Standard Specification for Safety of Bean Bag Chairs and Bean Bag Chair Covers<sup>1</sup>

This standard is issued under the fixed designation F1912; the number immediately following the designation indicates the year of original adoption or, in the case of revision, the year of last revision. A number in parentheses indicates the year of last reapproval. A superscript epsilon ( $\epsilon$ ) indicates an editorial change since the last revision or reapproval.

### INTRODUCTION

This safety specification addresses choking and suffocation hazards that may exist with children's use of bean bag chairs and bean bag chair covers.

From January 1973 to August 1995, the U.S. Consumer Product Safety Commission received reports of five deaths and 26 non-fatal incidents associated with bean bag chairs. Victims range in age from 14 months to 14 years. Deaths and injuries related to:

- (1) *Suffocation*—inside the bag,
- (2) *Suffocation*—from pellets clogging nose/throat,
- (3) *Choking*—pellets in mouth,
- (4) *Inhaling pellets*, and
- (5) *Earache*—pellets in ear.

iTeh Standards  
(<https://standards.iteh.ai>)  
Document Preview

### 1. Scope

1.1 This specification is intended to reduce choking and suffocation hazard(s) associated with bean bag chairs and bean bag chair covers.

1.2 This specification covers bean bag chairs and bean bag chair covers with and without zippers.

1.3 This specification covers two types of bean bag chairs:

1.3.1 Those designed to be refilled, and

1.3.2 Those designed with permanent closures and not intended to be refilled.

1.4 This specification does not cover products that include shredded foam or fiber-fill used as an internal filler material.

1.5 The values stated in inch-pound units are to be regarded as standard. The values given in parentheses are mathematical conversions to SI units that are provided for information only and are not considered standard.

1.6 *This standard does not purport to address all of the safety concerns, if any, associated with its use. It is the responsibility of the user of this standard to establish appropriate safety, health, and environmental practices and determine the applicability of regulatory limitations prior to use.*

<sup>1</sup> This specification is under the jurisdiction of ASTM Committee F15 on Consumer Products and is the direct responsibility of Subcommittee F15.39 on Bean Bag Chairs. Current edition approved Oct. 1, 2019 Aug. 1, 2021. Published October 2019 August 2021. Originally approved in 1998. Last previous edition approved in 2017 2019 as F1912 – 17: F1912 – 19. DOI: 10.1520/F1912-19; 10.1520/F1912-21.

1.7 This international standard was developed in accordance with internationally recognized principles on standardization established in the Decision on Principles for the Development of International Standards, Guides and Recommendations issued by the World Trade Organization Technical Barriers to Trade (TBT) Committee.

## 2. Terminology

### 2.1 Definitions of Terms Specific to This Standard:

2.1.1 *bean bag chair, n*—an article of furniture composed of a fabric, vinyl, leather, or other cover, no internal support mechanism, and a filling of polymeric or natural material beads.

2.1.2 *bean bag chair cover, n*—a bag or cover capable of being filled with polymeric or natural material beads, or a liner that contains polymeric or natural material beads.

2.1.3 *direct path, n*—an opening in a bean bag chair that allows a straight, 6 in. long, 1/8-in. diameter, cylindrical rod to penetrate from outside the bag to the beads or to a liner inside the bag that holds the beads if such a liner is used.

2.1.4 *non-refillable bean bag chair, n*—a bean bag chair not intended to be refilled with polymeric or natural material beads, or a liner that contains polymeric or natural material beads.

2.1.5 *permanently disabled, adj*—refers to a method(s) that will render the zipper inoperative in such a way that a consumer will need to destroy a zipper component in order to gain access into the bean bag through the zipper opening.

2.1.6 *refillable bean bag chair, n*—a bean bag chair intended to be refilled with polymeric or natural material beads, or a liner that contains polymeric or natural material beads.

## 3. Performance Requirements

3.1 ~~Bean bag chairs and bean bag covers shall be supplied with label(s) permanently attached and as specified in Section 4.~~

3.1 The durability test as specified in Section 5 shall not result in the failure of the bean bag's closures' components or projections, or failure of its seams that allow beads or filler material to escape, or allow access to the beads or liner holding the beads, if such a liner is used, by probe A defined in Fig. 1 driven by 5 lbf (22 N) or less.

3.2 *Bean Bag Chairs, with Zippers but Not Intended To Be Refilled:*

3.2.1 Prior to shipment, zippers shall be closed and permanently disabled.

3.2.2 The zipper shall be closed and disabled such that a force to open the zipper of 15 lbf (67 N) or more shall be required to produce a direct path.

3.3 *Bean Bag Chairs and Bean Bag Chair Covers, with Zippers and Intended To Be Refilled:*

3.3.1 The zipper shall always lock when closed. The use of a special tool as described in the product literature or supplied at the time of purchase shall be required to open or reopen the zipper. A force to open the zipper of 15 lbf (67 N) or more shall be required to produce a direct path unless a special tool is used.

3.3.2 Prior to shipment the zipper shall be closed and the special tool required to open or reopen the zipper shall be removed from the zipper.

NOTE 1—The performance requirement of 3.3.2 shall not apply to bean bag chair covers that are sold separately.

## 4. Label(s)

4.1 Bean bag chairs and bean bag chair covers shall be supplied with label(s) permanently attached and specified as follows.

4.2 Bean bag chairs having zippers but not intended for refilling shall have a permanent warning label as shown in Fig. 2.

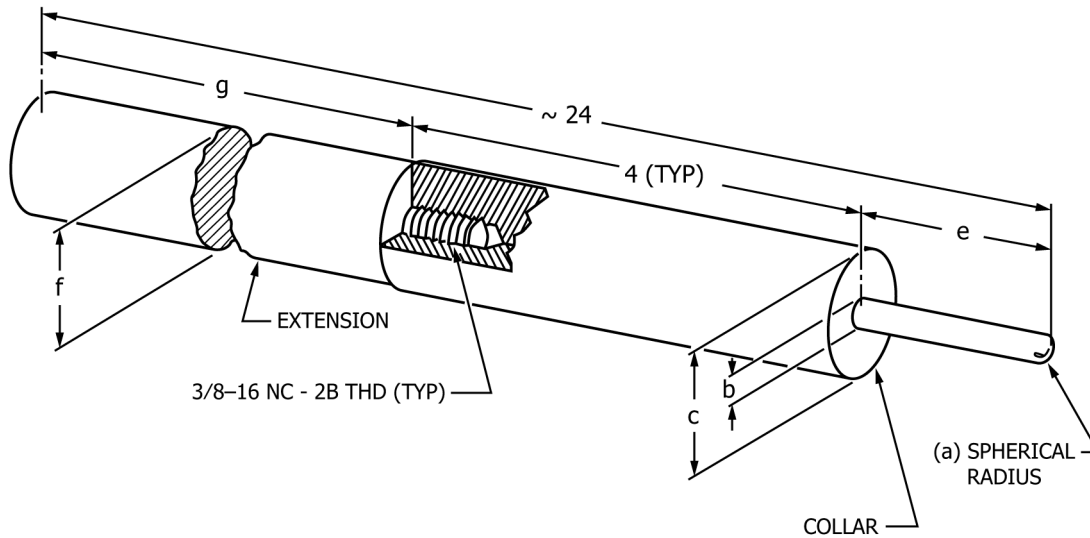

	a	b	c	e	f	g	
(CHILDREN 0-36 MONTHS INCL)	PROBE A	.110	.220	1.020	1.731	1	18 9/32
( " 37-96 " " )	PROBE B	.170	.340	1.510	2.280	1 1/2	17 25/32

ALL DIMENSIONS IN INCHES

FIG. 1 Accessibility Probes

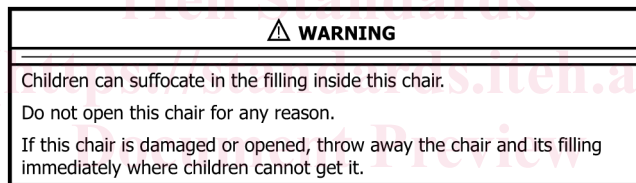

Lettering

Signal word:

Safety alert symbol:

Message text:

Minimum dimensions of label:

ALL CAPS

Black lettering on orange background

Sans serif-type font, 18 point

Black triangle with an orange exclamation mark

Black lettering on a white background

Sans serif-type font, 10 point

2¼ inches high and 4½ inches wide

FIG. 2 Warning Label for Bean Bag Chairs With Zippers That are Not Intended for Refilling

4.3 Bean bag chairs and bean bag chair covers having zippers that are intended for refilling shall have a permanent warning label as shown in Fig. 3, and information either on the warning label or on a separate permanent label describing detailed instructions for opening and reclosing the zipper.

## 5. Durability Test

5.1 *Scope*—This test evaluates the ability of the finished bean bag chair to contain the polymeric beads.

5.2 *Significance and Use*—This test method is designed to differentiate between acceptable and unacceptable bean bag chair design and construction. This test is not designed to simulate actual bean bag chair use.

5.3 *Procedure*: