



Designation: D5417 – 21

Standard Practice for Operation of the Vettermann Drum Tester¹

This standard is issued under the fixed designation D5417; the number immediately following the designation indicates the year of original adoption or, in the case of revision, the year of last revision. A number in parentheses indicates the year of last reappraisal. A superscript epsilon (ϵ) indicates an editorial change since the last revision or reappraisal.

1. Scope

1.1 This practice describes the equipment and operation of the Vettermann drum tester for testing pile yarn floor covering to produce changes in appearance and color due to changes in surface structure by mechanical action.

1.2 This practice is only applicable for use in testing unused pile floor covering of all types. It is not applicable for use in testing used pile yarn floor coverings.

1.3 The values stated in inch-pound units are to be regarded as standard. The values given in parentheses are mathematical conversions to SI units that are provided for information only and are not considered standard.

1.4 *This standard does not purport to address all of the safety concerns, if any, associated with its use. It is the responsibility of the user of this standard to establish appropriate safety, health, and environmental practices and determine the applicability of regulatory limitations prior to use.*

1.5 *This international standard was developed in accordance with internationally recognized principles on standardization established in the Decision on Principles for the Development of International Standards, Guides and Recommendations issued by the World Trade Organization Technical Barriers to Trade (TBT) Committee.*

2. Referenced Documents

2.1 *ASTM Standards:*²

D123 Terminology Relating to Textiles

D1776 Practice for Conditioning and Testing Textiles

D5684 Terminology Relating to Pile Floor Coverings

3. Terminology

3.1 For definitions of terms relating to Pile Floor Coverings, D13.21, refer to Terminology D5684.

¹ This practice is under the jurisdiction of ASTM Committee D13 on Textiles and is the direct responsibility of Subcommittee D13.21 on Pile Floor Coverings.

Current edition approved July 1, 2021. Published August 2021. Originally approved in 1999. Last previous edition approved in 2016 as D5417-16. DOI: 10.1520/D5417-21.

² For referenced ASTM standards, visit the ASTM website, www.astm.org, or contact ASTM Customer Service at service@astm.org. For *Annual Book of ASTM Standards* volume information, refer to the standard's Document Summary page on the ASTM website.

3.1.1 The following terms are relevant to this standard: carpet, finished, finished pile yarn floor covering, floor covering, lengthwise direction, pile, pile lay, pile yarn floor covering, pitch, practice, primary backing, secondary backing, textile floor covering, texture, tufted fabric.

3.2 For all other terminology related to textiles, refer to Terminology D123.

4. Summary of Practice

4.1 The test specimen is mounted in the rotatable drum with the pile surface towards the center of the drum and the edges under the retaining segments. A steel ball, with 14 rubber studs rolls randomly inside the drum on the pile surface for a specified number of revolutions.

5. Significance and Use

5.1 This equipment may be used to bring about the changes in texture on the surface of pile floor covering caused by mechanical action.

5.2 The acceptance criteria of this practice shall be set by mutual agreement between the purchaser and the supplier.

6. Apparatus and Material

6.1 *Vettermann Drum Tester* (See Fig. 1):

6.1.1 *Drum*, incorporating a revolution counter and four adjustable retaining segments (thickness: 0.60 ± 0.03 in. (15 ± 1 mm)) on each side wall of the drum. A free-running circular brush mounted in such a way that it lightly contacts the surface of specimens and loose fibers are continuously extracted by a vacuum cleaner. A vulcanized fiber backing sheet 93.3 by 10.6 by 0.06 in. (2320 by 270 by 1.5 mm) is loosely laid inside the drum. This sheet remains permanently in the drum.

6.1.2 The Vettermann drum dimensions are as follows:

Internal diameter	28.70 \pm 0.39 in.	(730 \pm 10 mm)
Internal depth	10.60 \pm 0.20 in.	(270 \pm 5 mm)
Effective depth	9.40 \pm 0.28 in.	(240 \pm 7 mm)
Thickness of curved surface	0.31 \pm 0.02 in.	(8 \pm 0.5 mm)

6.1.3 *Driving System*, with a speed of 1.65 rad/s (16 ± 1 rpm) and the direction of rotation is reversed every five

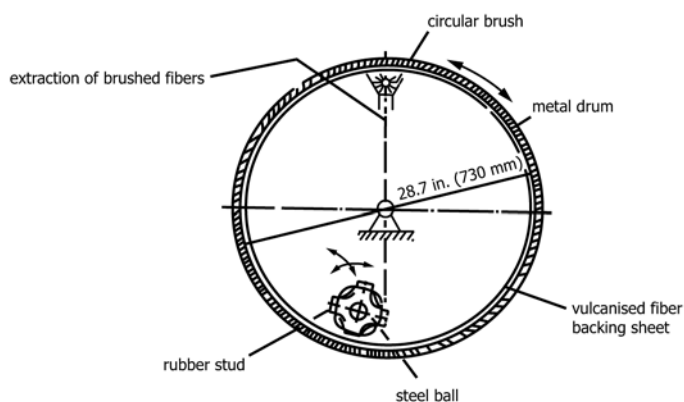

FIG. 1 Vettermann Drum Tester

minutes, stopping between reversals for approximately 1 s time intervals, with approximately one second stationary time.

6.1.4 *Protective Cage*, fits over the drum and must be in place prior to Vettermann drum rotation.

6.1.5 *Round Steel Ball*, fitted with fourteen cylindrical rubber studs located equally spaced on the ball surface. The studs are replaceable and are screwed into flat faces on the surface of the ball. (See Fig. 2.):

Diameter of ball	4.70 ± 0.01 in.	(120.0 ± 0.2 mm)
Distance between diametrically opposed flat stud-mounting faces	4.60 ± 0.01 in.	(118.0 ± 0.1 mm)
Mass without studs	15.0 ± 0.2 lb	(6800 ± 100 g)
Mass with studs	16.8 ± 0.2 lb	(7600 ± 100 g)

6.1.6 *Replaceable Rubber Studs*, are a composite rubber disk attached to a steel backing plate with integral mounting screw. The dimensions are:

Diameter	1.54 ± 0.02 in.	(39.0 ± 0.5 mm)
Total height including backing plate	0.59 ± 0.02 in.	(15.0 ± 0.5 mm)
Thickness of steel backing plate	0.12 in.	(3 mm)
Rubber hardness	48 ± 3	Shore A

6.1.6.1 The studs must be replaced after 500 000 revolutions of the drum. Unscrew the old studs and replace with new studs ensuring that each stud is properly tightened. Place

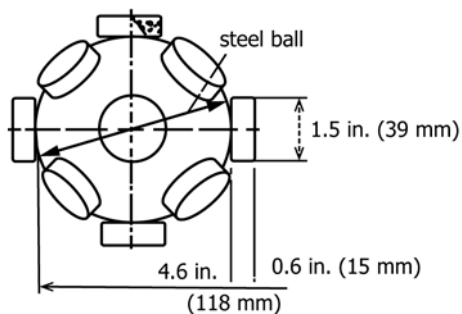

FIG. 2 Round Steel Ball

disposable specimens in the drum tester and condition the new studs by running the tester for 10 000 revolutions with the steel ball inside.

6.1.7 *Vacuum Cleaner*, upright type, approved by the CRI Seal of Approval Program, shall be acceptable for use in this practice. Alternatively, a hand-held vacuum that meets the following general specifications can be used: powered rotating brush, bagless design, HEPA filtration, ~7A motor, nozzle width 6.5 ± 0.3 in. (165 ± 7 mm). Replace the rotating brush when the bristles length changes more than 15 % of the original length.

6.1.8 *Cleaning Frame*, with a central rectangular aperture to receive the test specimen. The frame should be the same material as the test specimen or similar in construction to the test specimen. To ensure proper cleaning by the vacuum cleaner, it is recommended the frame and test specimen be mounted on a rigid backing sheet.

7. Reagent

7.1 *Solvent*—Ethyl alcohol ((CH₃)₂CHOH) or technical grade iso-propyl alcohol (CH₃)₂CHOH) are suitable. Do not use cellosolve, chlorinated or ketone solvents.

8. Preparation of Specimen

8.1 *Marking Specimen*—Before cutting out the test specimen, mark on the secondary backing the direction of manufacture with the head of the arrow pointing in the same direction as the lay of the pile.

8.2 *Size of Specimen*—Cut the specimen approximately 22.4 by 10.4 in. (570 by 265 mm). The long dimension shall be parallel to the lengthwise direction of the carpet. If smaller specimens are needed, a nominal size of 11.2 by 10.4 in. (285 by 265 mm) can be used with agreement from the customer. Take no specimen within 4 in. (100 mm) of the sample's edge.

8.2.1 When testing thick pile floor covering, it may be necessary to shorten the specimen length to approximately 22 in. (565 mm).

8.3 *Preparation*—Clean the specimen with an upright vacuum cleaner, condition it flat with pile surface up for a minimum of 12 h.

9. Conditioning

9.1 Condition the specimen in the standard atmosphere for testing textiles in accordance with Practice D1776.

10. Procedure

10.1 Perform this practice on a specimen prepared as described in Section 9, maintaining the Vettermann drum test in the standard atmosphere for testing textiles as per Practice D1776.

10.2 Remove the protective cage from the tester.

10.3 Loosen the outside bolts.

10.4 Wipe the inside of the drum and the steel ball with a clean lint free tissue and one of the recommended reagents.

10.5 Inspect the rubber studs on the steel ball for signs of wear or damage and replace as needed.