



Designation: **E190–14** E190 – 21

Standard Test Method for Guided Bend Test for Ductility of Welds¹

This standard is issued under the fixed designation E190; the number immediately following the designation indicates the year of original adoption or, in the case of revision, the year of last revision. A number in parentheses indicates the year of last reapproval. A superscript epsilon (ϵ) indicates an editorial change since the last revision or reapproval.

This standard has been approved for use by agencies of the U.S. Department of Defense.

1. Scope

1.1 This test method covers a guided bend test for the determination of soundness and ductility of welds in ferrous and nonferrous products. Flaws, not shown by X rays, ~~may can~~ appear in the surface of a specimen when it is subjected to progressive localized overstressing. ~~This guided bend test has been developed primarily for plates and is not intended to be substituted for other methods of bend testing.~~

1.2 The values stated in inch-pound units are to be regarded as standard. The values given in parentheses are mathematical conversions to SI units that are provided for information only and are not considered standard.

1.3 *This standard does not purport to address all of the safety concerns, if any, associated with its use. It is the responsibility of the user of this standard to establish appropriate ~~safety~~ safety, health, and ~~health~~ environmental practices and determine the applicability of regulatory limitations prior to use.*

1.4 *This international standard was developed in accordance with internationally recognized principles on standardization established in the Decision on Principles for the Development of International Standards, Guides and Recommendations issued by the World Trade Organization Technical Barriers to Trade (TBT) Committee.*

2. Referenced Documents

[ASTM E190-21](#)

<https://standards.iteh.ai/catalog/standards/sist/a4b2512c-3bd6-4aab-a2d7-69de4b222fb1/astm-e190-21>

2.1 *ASTM Standards:*²

[E6 Terminology Relating to Methods of Mechanical Testing](#)

2.2 *AWS Standard:*

[AWS A3.0M/A3.0 Standard Welding Terms and Definitions; Including Terms for Adhesive Bonding, Brazing, Soldering, Thermal Cutting, and Thermal Spraying](#)³

3. Terminology

3.1 Terms in this standard are defined in [E6 Terminology Relating to Methods of Mechanical Testing](#). These terms include bend test, ductility, guided bend, and testing machine.

3.2 Additional welding terms including defect, discontinuity, flaw, thermal cutting, weld root, weld face, and weldment are defined in [AWS A3.0M/A3.0:2010/A3.0M/A3.0](#).

¹ This test method is under the jurisdiction of ASTM Committee [E28](#) on Mechanical Testing and is the direct responsibility of Subcommittee [E28.02](#) on Ductility and Formability.

Current edition approved ~~May 1, 2014~~ July 1, 2021. Published ~~September 2014~~ August 2021. Originally approved in 1961. Last previous edition approved in ~~2008~~ 2014 as ~~E190–92 (2008)~~ E190 – 14. DOI: ~~10.1520/E0190-14~~ 10.1520/E0190-21.

² For referenced ASTM standards, visit the ASTM website, www.astm.org, or contact ASTM Customer Service at service@astm.org. For *Annual Book of ASTM Standards* volume information, refer to the standard's Document Summary page on the ASTM website.

³ Available from American Welding Society (AWS), 8669 NW 36 Street, #130, Miami, FL 33166-6672, <http://www.aws.org>.

4. Summary of Test Method

4.1 The specimen is bent in a U-shaped die by means of a centrally applied force to the weldment in a flat specimen supported at two positions equidistant from the line of force application. The specimen is forced into the die by a plunger having the shape necessary to produce the desired contour. The convex surface of the bent specimen is examined for cracks or other open flaws.

5. Significance and Use

5.1 The guided bend test as described in this test method is used to evaluate the quality of welds as a function of ductility as evidenced by their ability to resist cracking during bending.

6. Apparatus

6.1 The guided bend test jig or fixture is shown in Fig. 1.

7. Sampling

7.1 Sample in accord with the requirements of relevant specifications and codes.

8. Test Specimens

8.1 The types of specimens generally used for guided bend testing are rectangular ones machined from plates and pipes. The weld-face surface of the flat specimen contains the greater width of the weld material, while the opposite side is called the weld-root surface.

iTeh Standards
(https://standards.itih.ai)

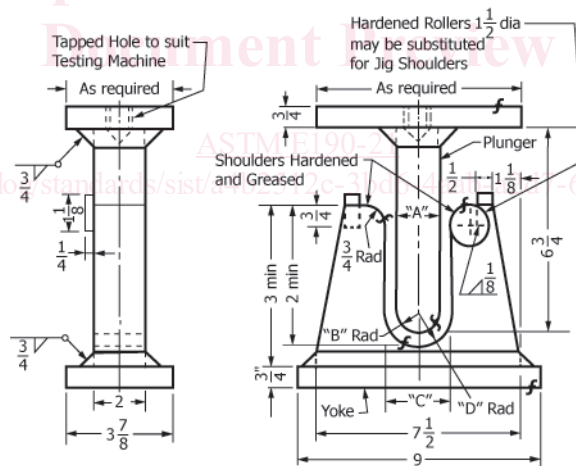

All dimensions shown in inches.

Thickness of Specimen in. (mm)	A, in. (mm)	B, in. (mm)	C, in. (mm)	D, in. (mm)
3/8 (9.5)	1 1/2 (38)	3/4 (19)	2 3/8 (60)	1 3/16 (30)
1/2 (3.2)	2 1/8 (54)	1 1/16 (27)	2 3/8 (60)	1 3/16 (30)
t	4t	2t	6t + 1/8 (+ 3.2)	3t + 1/16 (+ 1.6)

NOTE 1—Either hardened and greased shoulders or hardened rollers free to rotate shall be used.

NOTE 2—The shoulders or rollers shall have a minimum width of 2 in. (50.8 mm) for the placement of the specimen.

NOTE 3—The length of the specimen shall be such that the ends will not interfere with the seating of the specimen.

NOTE 4—The plunger shall be fitted with an appropriate base and provisions for attachment to the testing machine and shall be designed to minimize deflection and misalignment.

NOTE 5—The die member shall be fitted with an appropriate base designed to safeguard against deflection or misalignment and equipped with means for keeping the shoulders or rollers over the midpoint and aligned with respect to the plunger.

NOTE 6—Appropriate test specimen thickness, bend radius, and dimensions A, B, C, and D should be selected based on material and the applicable welding code.

FIG. 1 Guided Bend Test Jig

8.1.1 *Transverse Side Bend*—The weld is transverse to the longitudinal axis of the specimen, which is bent so that either one of the side surfaces becomes the convex surface of the bent specimen (Fig. 2 and Fig. 3).

8.1.2 *Transverse Face Bend*—The weld is transverse to the longitudinal axis of the specimen, which is bent so that the weld-face surface becomes the convex surface of the bent specimen (Fig. 4).

8.1.3 *Transverse Root Bend*—The weld is transverse to the longitudinal axis of the specimen, which is bent so that the weld-root surface becomes the convex surface of the bent specimen (Fig. 4).

8.1.4 *Longitudinal Face Bend*—The weld is parallel to the longitudinal axis of the specimen, which is bent so that the weld-face surface becomes the convex surface of the bent specimen (Fig. 5).

8.1.5 *Longitudinal Root Bend*—The weld is parallel to the longitudinal axis of the specimen, which is bent so that the weld-root surface becomes the convex surface of the bent specimen (Fig. 5).

9. Procedure

9.1 Bend the guided-bend specimens in a test jig that is substantially in accordance with Fig. 1. Place transverse specimens on the die member of the jig with the weld at midspan. Place face-bend specimens with the weld face directed toward the gap. Place root-bend specimens with the weld root directed toward the gap. Place side-bend specimens with the side showing the greater flaws toward the gap. If no significant flaws are evident, either side may be chosen.

9.2 Any convenient means may be used for moving the plunger with relation to the die, but it must shall be steady and without any significant lateral motion. Apply the force until the specimen conforms to a U-shape, and until a 1/8-in. (3.2 mm) diameter wire cannot be inserted between the specimen and any point on the curvature of the plunger member of the jig, unless the specimen fails earlier.

10. Interpretation of Results

10.1 Examine the convex surface of the bent specimen for cracks or other open flaws.

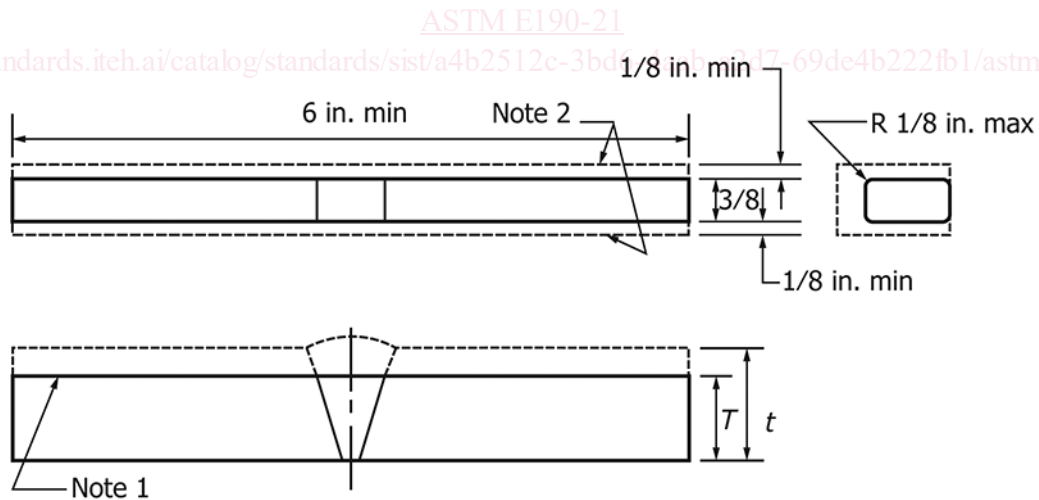

t, in. (mm)	T, in.
3/8 to 1 1/2 (9.5 to 38)	t
>1 1/2 (38)	See Note 1 above
>1 1/2 (38)	See Note 1

NOTE 1—Cut along this line when t exceeds 1 1/2 in. Edge may be thermally cut and may or may not be machined.

NOTE 2—If thermally cut, machine not less than 1/8 in. from edges

NOTE 3—For plates over 1 1/2 in. (38 mm) thick, cut specimen into approximately equal strips between 3/4 and 1 1/2 (19 and 38 mm) wide and test each strip.

FIG. 2 Side-Bend Specimen for Ferrous Materials