



Designation: C1259 – 21

Standard Test Method for Dynamic Young's Modulus, Shear Modulus, and Poisson's Ratio for Advanced Ceramics by Impulse Excitation of Vibration¹

This standard is issued under the fixed designation C1259; the number immediately following the designation indicates the year of original adoption or, in the case of revision, the year of last revision. A number in parentheses indicates the year of last reapproval. A superscript epsilon (ϵ) indicates an editorial change since the last revision or reapproval.

1. Scope*

1.1 This test method covers determination of the dynamic elastic properties of advanced ceramics at ambient temperatures. Specimens of these materials possess specific mechanical resonant frequencies that are determined by the elastic modulus, mass, and geometry of the test specimen. The dynamic elastic properties of a material can therefore be computed if the geometry, mass, and mechanical resonant frequencies of a suitable (rectangular, cylindrical, or disc geometry) test specimen of that material can be measured. The resonant frequencies in flexure and torsion are measured by excitation of vibrations of the test specimen in a supported mode by a singular elastic strike with an impulse tool (Section 4 and Fig. 1, Fig. 3, and Fig. 4). Dynamic Young's modulus is determined using the resonant frequency in the flexural mode of vibration. The dynamic shear modulus, or modulus of rigidity, is found using torsional resonant vibrations. Dynamic Young's modulus and dynamic shear modulus are used to compute Poisson's ratio.

1.2 Although not specifically described herein, this test method can also be performed at cryogenic and high temperatures with suitable equipment modifications and appropriate modifications to the calculations to compensate for thermal expansion, in accordance with Subsections 9.2, 9.3, and 10.4 of Test Method C1198.

1.3 There are material-specific ASTM standards that cover the determination of resonance frequencies and elastic properties of specific materials by sonic resonance or by impulse excitation of vibration. Test Methods C215, C623, C747, C848, C1198, E1875, and E1876 may differ from this test method in several areas (for example, sample size, dimensional tolerances, sample preparation, calculation details, etc.). The testing of those materials should be done in compliance with the appropriate material-specific standards. Where possible, the

¹ This test method is under the jurisdiction of ASTM Committee C28 on Advanced Ceramics and is the direct responsibility of Subcommittee C28.01 on Mechanical Properties and Performance.

Current edition approved Aug. 1, 2021. Published August 2021. Originally approved in 1994. Last previous edition approved in 2015 as C1259 – 15. DOI: 10.1520/C1259-21.

procedures, sample specifications, and calculations in this standard are consistent with the other test methods.

1.4 This test method uses test specimens in bar, rod, and disc geometries. The rod and bar geometries are described in the main body. The disc geometry is addressed in Annex A1.

1.5 A modification of this test method can be used for quality control and nondestructive evaluation, using changes in resonant frequency to detect variations in specimen geometry and mass and internal flaws in the specimen. (See 5.5.)

1.6 The values stated in SI units are to be regarded as standard. The non-SI unit values given in parentheses are for information only and are not considered standard.

1.7 *This standard does not purport to address all of the safety concerns, if any, associated with its use. It is the responsibility of the user of this standard to establish appropriate safety, health, and environmental practices and determine the applicability of regulatory limitations prior to use.*

1.8 *This international standard was developed in accordance with internationally recognized principles on standardization established in the Decision on Principles for the Development of International Standards, Guides and Recommendations issued by the World Trade Organization Technical Barriers to Trade (TBT) Committee.*

2. Referenced Documents

2.1 *ASTM Standards:*²

C215 Test Method for Fundamental Transverse, Longitudinal, and Torsional Resonant Frequencies of Concrete Specimens

C372 Test Method for Linear Thermal Expansion of Porcelain Enamel and Glaze Frits and Fired Ceramic Whiteware Products by Dilatometer Method

C623 Test Method for Young's Modulus, Shear Modulus, and Poisson's Ratio for Glass and Glass-Ceramics by Resonance

² For referenced ASTM standards, visit the ASTM website, www.astm.org, or contact ASTM Customer Service at service@astm.org. For *Annual Book of ASTM Standards* volume information, refer to the standard's Document Summary page on the ASTM website.

*A Summary of Changes section appears at the end of this standard

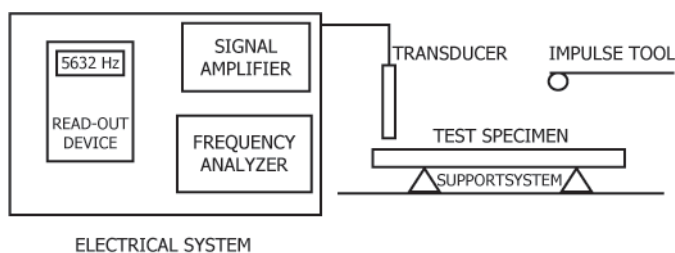

FIG. 1 Block Diagram of Typical Test Apparatus

- C747 Test Method for Moduli of Elasticity and Fundamental Frequencies of Carbon and Graphite Materials by Sonic Resonance
- C848 Test Method for Young's Modulus, Shear Modulus, and Poisson's Ratio For Ceramic Whitewares by Resonance
- C1145 Terminology of Advanced Ceramics
- C1161 Test Method for Flexural Strength of Advanced Ceramics at Ambient Temperature
- C1198 Test Method for Dynamic Young's Modulus, Shear Modulus, and Poisson's Ratio for Advanced Ceramics by Sonic Resonance
- E6 Terminology Relating to Methods of Mechanical Testing
- E177 Practice for Use of the Terms Precision and Bias in ASTM Test Methods
- E691 Practice for Conducting an Interlaboratory Study to Determine the Precision of a Test Method
- E1875 Test Method for Dynamic Young's Modulus, Shear Modulus, and Poisson's Ratio by Sonic Resonance
- E1876 Test Method for Dynamic Young's Modulus, Shear Modulus, and Poisson's Ratio by Impulse Excitation of Vibration
- E2001 Guide for Resonant Ultrasound Spectroscopy for Defect Detection in Both Metallic and Non-metallic Parts
- 2.2 ISO Standard.³
- ISO 14704 Test Method for Flexural Strength of Monolithic Ceramics at Room Temperatures

3. Terminology

3.1 Definitions:

3.1.1 The definitions of terms relating to mechanical testing appearing in Terminology E6 should be considered as applying to the terms used in this test method. The definitions of terms relating to advanced ceramics appearing in Terminology C1145 should be considered as applying to the terms used in this test method. Directly pertinent definitions as listed in Terminologies E6 and C1145 are shown in the following paragraphs with the appropriate source given in brackets.

3.1.2 *advanced ceramic, n*—a highly engineered, high-performance, predominately nonmetallic, inorganic, ceramic material having specific functional attributes. (C1145)

3.1.3 *dynamic elastic modulus, n*—the elastic modulus, either Young's modulus or shear modulus, that is measured in a dynamic mechanical measurement. (E1876)

3.1.4 *dynamic mechanical measurement, n*—a technique in which either the modulus or damping, or both, of a substance under oscillatory load or displacement is measured as a function of temperature, frequency, or time, or combination thereof. (E1876)

3.1.5 *elastic limit [FL⁻²], n*—the greatest stress that a material is capable of sustaining without permanent strain remaining upon complete release of the stress. (E6)

3.1.6 *elastic modulus [FL⁻²], n*—the ratio of stress to strain below the proportional limit. (E6)

3.1.7 *Poisson's ratio (μ) [nd], n*—the absolute value of the ratio of transverse strain to the corresponding axial strain resulting from uniformly distributed axial stress below the proportional limit of the material.

3.1.7.1 *Discussion*—In isotropic materials, Young's Modulus (*E*), shear modulus (*G*), and Poisson's ratio (*μ*) are related by the following equation:

$$\mu = (E/2G) - 1 \quad (1) \quad (E6)$$

3.1.8 *proportional limit [FL⁻²], n*—the greatest stress that a material is capable of sustaining without deviation from proportionality of stress to strain (Hooke's law). (E6)

3.1.9 *shear modulus (G) [FL⁻²], n*—the elastic modulus in shear or torsion. Also called modulus of rigidity or torsional modulus. (E6)

3.1.10 *Young's modulus (E) [FL⁻²], n*—the elastic modulus in tension or compression. (E6)

3.2 Definitions of Terms Specific to This Standard:

3.2.1 *antinodes, n*—two or more locations that have local maximum displacements, called antinodes, in an unconstrained slender rod or bar in resonance. For the fundamental flexure resonance, the antinodes are located at the two ends and the center of the specimen.

3.2.2 *elastic, adj*—the property of a material such that an application of stress within the elastic limit of that material making up the body being stressed will cause an instantaneous and uniform deformation, which will be eliminated upon removal of the stress, with the body returning instantly to its original size and shape without energy loss. Most advanced ceramics conform to this definition well enough to make this resonance test valid.

3.2.3 *flexural vibrations, n*—the vibrations that occur when the displacements in a slender rod or bar are in a plane normal to the length dimension.

3.2.4 *homogeneous, adj*—the condition of a specimen such that the composition and density are uniform, so that any smaller specimen taken from the original is representative of the whole. Practically, as long as the geometrical dimensions of the test specimen are large with respect to the size of individual grains, crystals, components, pores, or microcracks, the body can be considered homogeneous.

3.2.5 *in-plane flexure, n*—for rectangular parallelepiped geometries, a flexure mode in which the direction of displacement is in the major plane of the test specimen.

³ Available from American National Standards Institute (ANSI), 25 W. 43rd St., 4th Floor, New York, NY 10036, <http://www.ansi.org>.

3.2.6 *isotropic, adj*—the condition of a specimen such that the values of the elastic properties are the same in all directions in the material. Advanced ceramics are considered isotropic on a macroscopic scale, if they are homogeneous and there is a random distribution and orientation of phases, crystallites, components, pores, or microcracks.

3.2.7 *nodes, n*—one or more locations in a slender rod or bar in resonance having a constant zero displacement. For the fundamental flexural resonance of such a rod or bar, the nodes are located at $0.224 L$ from each end, where L is the length of the specimen.

3.2.8 *out-of-plane flexure, n*—for rectangular parallelepiped geometries, a flexure mode in which the direction of displacement is perpendicular to the major plane of the test specimen.

3.2.9 *resonant frequency, n*—naturally occurring frequencies of a body driven into flexural, torsional, or longitudinal vibration that are determined by the elastic modulus, mass, and dimensions of the body. The lowest resonant frequency in a given vibrational mode is the fundamental resonant frequency of that mode.

3.2.10 *slender rod or bar, n*—in dynamic elastic property testing, a specimen whose ratio of length to minimum cross-sectional dimension is at least 5 and preferably in the range of 20 to 25.

3.2.11 *torsional vibrations, n*—the vibrations that occur when the oscillations in each cross-sectional plane of a slender rod or bar are such that the plane twists around the length dimension axis.

4. Summary of Test Method

4.1 This test method measures the fundamental resonant frequency of test specimens of suitable geometry (bar, rod, or disc) by exciting them mechanically by a singular elastic strike with an impulse tool. A transducer (for example, contact accelerometer or noncontacting microphone) senses the resulting mechanical vibrations of the specimen and transforms them into electric signals. Specimen supports, impulse locations, and signal pickup points are selected to induce and measure specific modes of the transient vibrations. The signals are analyzed, and the fundamental resonant frequency is isolated and measured by the signal analyzer, which provides a numerical reading that is (or is proportional to) either the frequency or the period of the specimen vibration. The appropriate fundamental resonant frequencies, dimensions, and mass of the specimen are used to calculate dynamic Young's modulus, dynamic shear modulus, and Poisson's ratio.

5. Significance and Use

5.1 This test method may be used for material development, characterization, design data generation, and quality control purposes.

5.2 This test method is specifically appropriate for determining the modulus of advanced ceramics that are elastic, homogeneous, and isotropic (1).⁴

5.3 This test method addresses the room temperature determination of dynamic moduli of elasticity of slender bars (rectangular cross section) and rods (cylindrical). Flat plates and discs may also be measured similarly, but the required equations for determining the moduli are not addressed herein.

5.4 This dynamic test method has several advantages and differences from static loading techniques and from resonant techniques requiring continuous excitation.

5.4.1 The test method is nondestructive in nature and can be used for specimens prepared for other tests. The specimens are subjected to minute strains; hence, the moduli are measured at or near the origin of the stress-strain curve, with the minimum possibility of fracture.

5.4.2 The impulse excitation test uses an impact tool and simple supports for the test specimen. There is no requirement for complex support systems that require elaborate setup or alignment.

5.5 This technique can be used to measure resonant frequencies alone for the purposes of quality control and acceptance of test specimens of both regular and complex shapes. A range of acceptable resonant frequencies is determined for a specimen with a particular geometry and mass. Deviations in specimen dimensions or mass and internal flaws (cracks, delaminations, inhomogeneities, porosity, etc.) will change the resonant frequency for that specimen. Any specimen with a resonant frequency falling outside the prescribed frequency range is rejected. The actual modulus of each specimen need not be determined as long as the limits of the selected frequency range are known to include the resonant frequency that the specimen must possess if its geometry and mass and internal structure are within specified tolerances. The technique is particularly suitable for testing specimens with complex geometries (other than parallelepipeds, cylinders/rods, or discs) that would not be suitable for testing by other procedures. This is similar to the evaluation method described in Guide E2001.

5.6 If a thermal treatment or an environmental exposure affects the elastic response of the test specimen, this test method may be suitable for the determination of specific effects of thermal history, environment exposure, etc. Specimen descriptions should include any specific thermal treatments or environmental exposures that the specimens have received.

6. Interferences

6.1 The relationships between resonant frequency and dynamic modulus presented herein are specifically applicable to homogeneous, elastic, isotropic materials.

6.1.1 This method of determining the moduli is applicable to composite ceramics and inhomogeneous materials only with careful consideration of the effect of inhomogeneities and anisotropy. The character (volume fraction, size, morphology, distribution, orientation, elastic properties, and interfacial

⁴ The boldface numbers in parentheses refer to the list of references at the end of this test method.

bonding) of the reinforcement and inhomogeneities in the specimens will have a direct effect on the elastic properties of the specimen as a whole. These effects must be considered in interpreting the test results for composites and inhomogeneous materials.

6.1.2 The procedure involves measuring transient elastic vibrations. Materials with very high damping capacity may be difficult to measure with this technique if the vibration damps out before the frequency counter can measure the signal (commonly within three to five cycles).

6.1.3 If specific surface treatments (coatings, machining, grinding, etching, etc.) change the elastic properties of the near-surface material, there will be accentuated effects on the properties measured by this flexural method, as compared to static/bulk measurements by tensile or compression testing.

6.1.4 The test method is not satisfactory for specimens that have major discontinuities, such as large cracks (internal or surface) or voids.

6.2 This test method for determining moduli is limited to specimens with regular geometries (rectangular parallelepiped, cylinders, and discs) for which analytical equations are available to relate geometry, mass, and modulus to the resonant vibration frequencies. The test method is not appropriate for determining the elastic properties of materials that cannot be fabricated into such geometries.

6.2.1 The analytical equations assume parallel and concentric dimensions for the regular geometries of the specimen. Deviations from the specified tolerances for the dimensions of the specimens will change the resonant frequencies and introduce error into the calculations.

6.2.2 Edge treatments such as chamfers or radii are not considered in the analytical equations. Edge chamfers on flexure bars prepared according to Test Method C1161 will change the resonant frequency of the test bars and introduce error into the calculations of the dynamic modulus. It is recommended that specimens for this test method not have chamfered or rounded edges. Alternately, if narrow rectangular specimens with chamfers or edge radii are tested, then the procedures in Annex A2 should be used to correct the calculated Young's modulus, E .

6.2.3 For specimens with as-fabricated and rough or uneven surfaces, variations in dimensions can have a significant effect in the calculations. For example, in the calculation of dynamic modulus, the modulus value is inversely proportional to the cube of the thickness. Uniform specimen dimensions and precise measurements are essential for accurate results.

6.3 The test method assumes that the specimen is vibrating freely, with no significant restraint or impediment. Specimen supports should be designed and located properly in accordance with 9.3.1, 9.4.1, and 9.5.1 so the specimen can vibrate freely in the desired mode. In using direct contact transducers, the transducer should be positioned away from antinodes and with minimal force to avoid interference with free vibration. With noncontacting transducers, the maximum sensitivity is accomplished by placing the transducer at an antinode.

6.4 Proper location of the impulse point and transducer is important in introducing and measuring the desired vibration

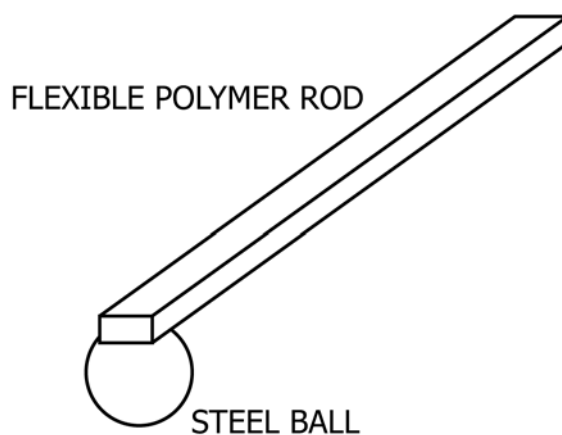

FIG. 2 Diagram of Typical Impulse Tool for Small Specimens

mode. The locations of the impulse point and transducer should not be changed in multiple readings; changes in position may develop and detect alternate vibration modes. In the same manner, the force used in impacting should be consistent in multiple readings.

6.5 If the frequency readings are not repeatable for a specific set of impulse and transducer locations on a specimen, it may be because several different modes of vibration are being developed and detected in the test. The geometry of the test bar and desired vibration mode should be evaluated and used to identify the nodes and antinodes of the desired vibrations. More consistent measurements may be obtained if the impulse point and transducer locations are shifted to induce and measure the single desired mode of vibration.

7. Apparatus

7.1 Apparatus suitable for accurately detecting, analyzing, and measuring the fundamental resonant frequency or period of a vibrating free-free beam is used. The test apparatus is shown in Fig. 1. It consists of an impulse tool, a suitable pickup transducer to convert the mechanical vibration into an electrical signal, an electronic system (consisting of a signal conditioner/amplifier, a signal analyzer, and a frequency read-out device), and a support system. Commercial instrumentation is available that measures the frequency or period of the vibrating specimen.

7.2 *Impulse Tool*—The exciting impulse is imparted by lightly striking the specimen with a suitable implement. This implement should have most of its mass concentrated at the point of impact and have mass sufficient to induce a measurable mechanical vibration, but not so large as to displace or damage the specimen physically. In practice, the size and geometry of the impulse tool depends on the size and weight of the specimen and the force needed to produce vibration. For commonly tested geometries (small bars, rods, and discs) in advanced ceramics, an example of such an impulse tool would be a steel sphere 0.5 cm in diameter glued to the end of a flexible 10 cm long polymer rod. (See Fig. 2.) An alternate impulse tool would be a solid metal, ceramic, or polymer sphere (0.1 to 1.0 cm in diameter) dropped on the specimen through a guide tube to ensure proper impulse position.

7.3 Signal Pickup—Signal detection can be via transducers in direct contact with the specimen or by noncontact transducers. Contact transducers are commonly accelerometers using piezoelectric or strain gage methods to measure the vibration. Noncontact transducers are commonly acoustic microphones, but they may also use laser, magnetic, or capacitance methods to measure the vibration. The frequency range of the transducer shall be sufficient to measure the expected frequencies of the specimens of interest. A suitable range would be 100 Hz to 50 kHz for most advanced ceramic test specimens. (Smaller and stiffer specimens vibrate at higher frequencies.) The frequency response of the transducer across the frequency range of interest shall have a bandwidth of at least 10 % of the maximum measured frequency before -3 dB power loss occurs.

7.4 Electronic System—The electronic system consists of a signal conditioner/amplifier, signal analyzer, and a frequency readout device. The system should have accuracy and precision sufficient to measure the frequencies of interest to an accuracy of 0.1 %. The signal conditioner/amplifier should be suitable to power the transducer and provide and appropriate amplified signal to the signal analyzer. The signal analysis system consists of a frequency counting device and a readout device. Appropriate devices are frequency counter systems with storage capability or digital storage oscilloscopes with a frequency counter module. With the digital storage oscilloscope, a Fast Fourier Transform signal analysis system may be useful for analyzing more complex waveforms and identifying the fundamental resonant frequency.

7.5 Support System—The support shall serve to isolate the specimen from extraneous vibration without restricting the desired mode of specimen vibration. Appropriate materials should be stable at the test temperatures. Support materials can be either soft or rigid for ambient conditions. Examples of soft materials would be a compliant elastomeric material, such as polyurethane foam strips. Such foam strips would have simple flat surfaces for the specimen to rest on. Rigid materials, such as metal or ceramic, should have sharp knife edges or cylindrical surfaces on which the specimen should rest. The rigid supports should be resting on isolation pads to prevent ambient vibrations from being picked up by the transducer. Wire suspension can also be used. Specimens shall be supported along node lines appropriate for the desired vibration in the locations described in Section 8.

8. Test Specimen

8.1 The specimens shall be prepared so that they are either rectangular or circular in cross section. Either geometry can be used to measure both dynamic Young's modulus and dynamic shear modulus. Although the equations for computing shear modulus with a cylindrical specimen are both simpler and more accurate than those used with a rectangular bar, experimental difficulties in obtaining torsional resonant frequencies for a cylindrical specimen usually preclude its use for determining shear modulus. (See [Annex A1](#) for disc specimens.)

8.2 Resonant frequencies for a given specimen are functions of the specimen dimensions as well as its mass and moduli;

dimensions should therefore be selected with this relationship in mind. The selection of size shall be made so that, for an estimated modulus, the resonant frequencies measured will fall within the range of frequency response of the transducers and electronics used. For a slender rod, the ratio of length to minimum cross-sectional dimension shall have a value of at least 10. However, a ratio of approximately $20 \approx 25$ is preferred for ease in calculation. For shear modulus measurements of rectangular bars, a ratio of width to thickness of 5 or greater is recommended for minimizing experimental difficulties.

8.3 All surfaces on the rectangular specimen shall be flat. Opposite surfaces across the length and width shall be parallel within 0.01 mm or ± 0.1 %, whichever is greater. Opposite surfaces across the thickness shall be parallel within 0.002 mm or ± 0.1 %, whichever is greater. The cylindrical specimen shall be round and constant in diameter within 0.002 mm or ± 0.1 %, whichever is greater.

8.4 Test specimen mass shall be determined within ± 0.1 % or 10 mg, whichever is greater.

8.5 Test specimen length shall be measured to within ± 0.1 %. Test specimen cross-sectional dimensions (thickness and width in rectangular beams; diameter in cylindrical rods) shall be measured within ± 0.1 % or 0.01 mm at three equally spaced locations along the length and an average value determined.

8.6 Porous materials and those susceptible to hydration should be dried in air at 120 °C in a drying oven until the mass is constant (less than 0.1 % or 10 mg difference in measured mass with 30 min of additional drying).

8.7 It is recommended that the laboratory obtain and maintain an internal reference specimen with known and recorded fundamental resonant frequencies in flexure and torsion. The reference specimen should be used to check and confirm the operation of the test system on a regular basis. It can also be used to train operators in the proper test setup and test procedure. The reference specimen can be a standard ceramic material (alumina, silicon carbide, zirconia, etc.) or it may be of a similar size, composition, and microstructure to the types of ceramic specimens commonly tested at the laboratory. The reference specimen must meet the size, dimensional tolerances, and surface finish requirements of Section 8.

9. Procedure

9.1 Activate all electrical equipment, and allow it to stabilize according to the manufacturer's recommendations.

9.2 Use a test specimen established as a verification/calibration standard to verify the equipment response and accuracy.

9.3 *Fundamental Flexural Resonant Frequency (Out-of-Plane Flexure):*

9.3.1 Place the specimen on the supports located at the fundamental nodal points (0.224 L from each end; see [Fig. 3](#)).

9.3.2 Determine the direction of maximum sensitivity for the transducer. Orient the transducer so that it will detect the desired vibration.

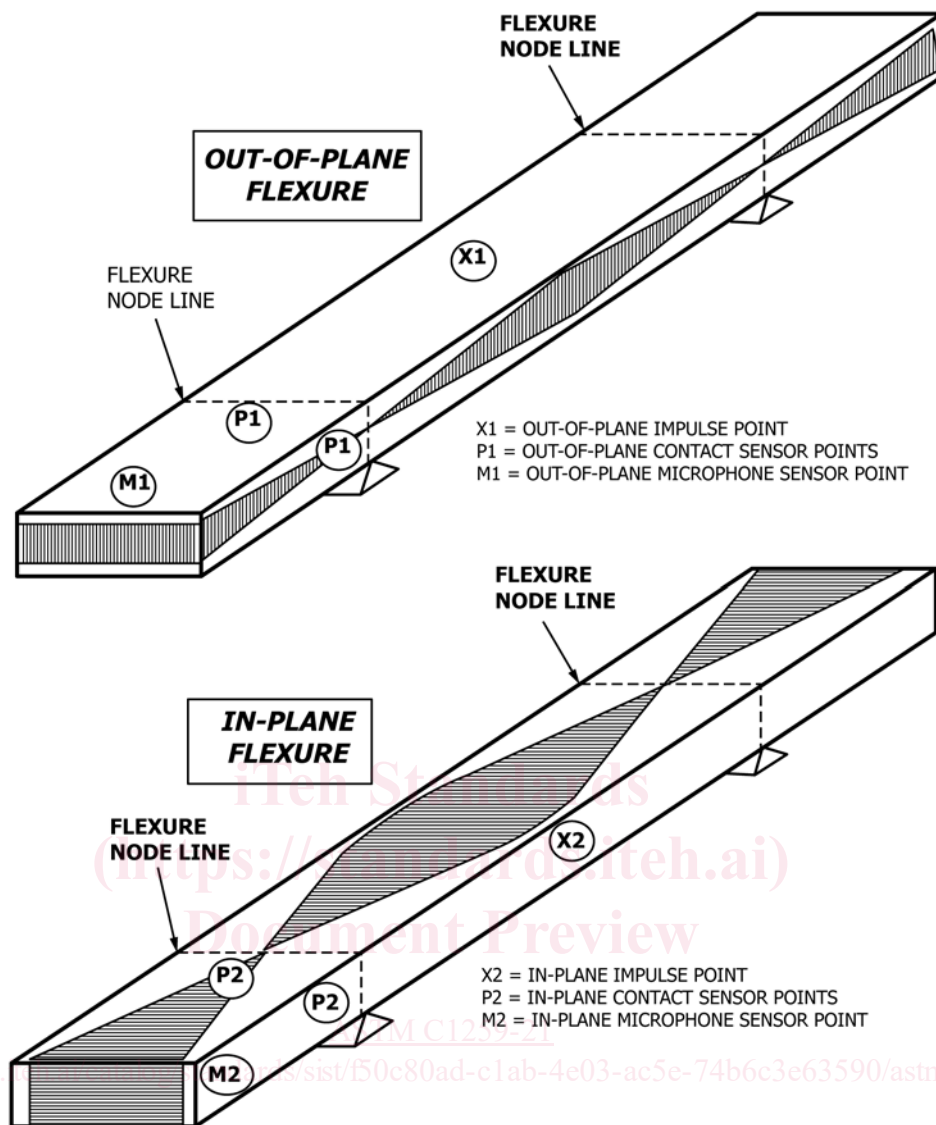

FIG. 3 Rectangular Specimens Tested for In-Plane and Out-of-Plane Flexure

9.3.2.1 *Direct Contact Transducers*—Place the transducer in contact with the test specimen to pick up the desired vibration. If the transducer is placed at an antinode (location of maximum displacement), it may mass load the specimen and modify the natural vibration. The transducer should preferably be placed only as far from the nodal points as necessary to obtain a reading (see Fig. 3). This location will minimize the damping effect from the contacting transducer. The transducer contact force should be consistent, with good response and minimal interference with the free vibration of the specimen.

9.3.2.2 *Noncontact Transducers*—Place the noncontact transducer over an antinode point and close enough to the test specimen to pick up the desired vibration, but not so close as to interfere with the free vibration (see Fig. 3).

9.3.3 Strike the specimen lightly and elastically, either at the center of the specimen or at the opposite end of the specimen from the detecting transducer (see Fig. 3).

9.3.4 Record the resultant reading, and repeat the test until a recommended ten readings are obtained that lie within $\pm 10\%$ of the mean. The round-robin interlaboratory study (12.2) showed that data points significantly ($>10\%$) out of range were measurements of spurious vibration modes or secondary harmonics. If ten readings cannot be taken, a minimum of five readings that lie within $\pm 10\%$ of the mean shall be required for estimating the mean. Use the mean of these readings to determine the fundamental resonant frequency in flexure.

9.4 *Fundamental Flexural Resonant Frequency (In-Plane Flexure)*:

9.4.1 This procedure is the same as that above (9.3), except that the direction of vibration is in the major plane of the specimen. This measurement can be performed in two ways. In one case, move the transducer and impulse tool 90° around the

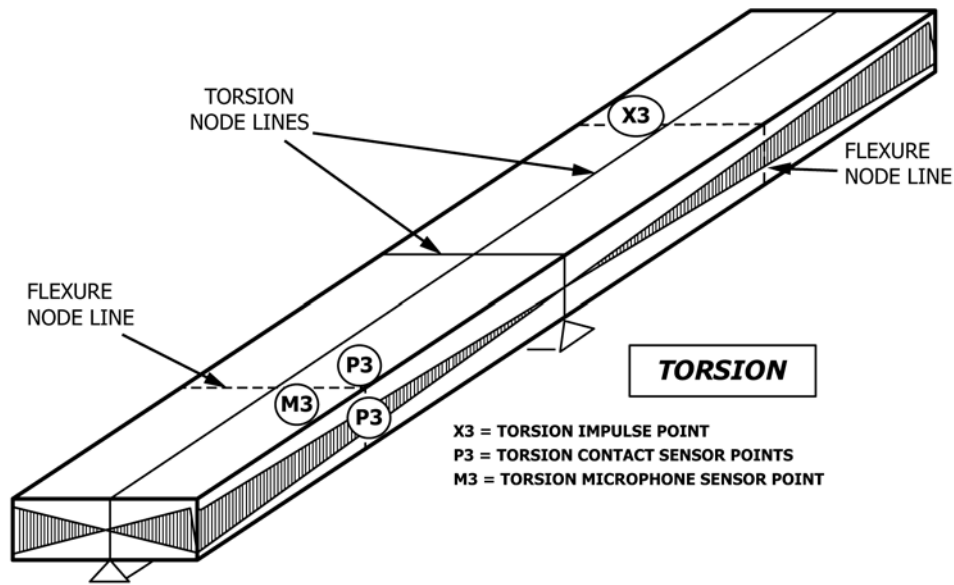

FIG. 4 Rectangular Specimen Tested for Torsional Vibration

long axis of the test specimen to introduce and detect vibrations in the major plane (see Fig. 3). In the alternate method, rotate the test bar 90° around its long axis and reposition it on the specimen supports. Transpose the width and thickness dimensions in the calculations. For homogeneous, isotropic materials, the calculated moduli should be the same as the moduli calculated from the out-of-plane frequency. The comparison of in-plane and out-of-plane frequency measurements can thus be used as a cross check of experimental methods and calculations.

9.5 Fundamental Torsional Resonant Frequency:

9.5.1 Support the specimen at the midpoint of its length and width (the torsional nodal planes) (see Fig. 4).

9.5.2 Locate the transducer at one quadrant of the specimen, preferably at approximately 0.224 L from one end and toward the edge. This location is a nodal point of flexural vibration and will minimize the possibility of detecting a spurious flexural mode (see Fig. 4).

9.5.3 Strike the specimen on the quadrant diagonally opposite the transducer, again at 0.224 L from the end and near the edge. Striking at a flexural nodal point will minimize the possibility of exciting a flexural mode of vibration (see Fig. 4).

9.5.4 Record the resultant reading, and repeat the test until a recommended ten readings are obtained that lie within ±10 % of the mean. The round-robin interlaboratory study (12.2) showed that data points significantly (>10 %) out of range were measurements of spurious vibration modes or secondary harmonics. If ten readings cannot be taken, a minimum of five readings that lie within ±10 % of the mean shall be required for estimating the mean. Use the mean of these readings to determine the fundamental resonant frequency in torsion.

10. Calculation

10.1 Dynamic Young's Modulus (2, 3):

10.1.1 For the fundamental flexure frequency of a rectangular bar (2),

$$E = 0.9465(mf_f^2/b)(L^3/t^3) T_1 \tag{2}$$

where:

- E = Young's modulus, Pa,
- m = mass of the bar, g (see Note 2),
- b = width of the bar, mm (see Notes 1 and 2),
- L = length of the bar, mm (see Note 2),
- t = thickness of the bar, mm (see Notes 1 and 2),
- f_f = fundamental resonant frequency of bar in flexure, Hz, and
- T₁ = correction factor for fundamental flexural mode to account for finite thickness of bar, Poisson's ratio, etc.

$$T_1 = 1 + 6.585 (1 + 0.0752 \mu + 0.8109 \mu^2) (t/L)^2 - 0.868 (t/L)^4 \tag{3}$$

$$- \left[\frac{8.340 (1 + 0.2023 \mu + 2.173 \mu^2) (t/L)^4}{1.000 + 6.338 (1 + 0.1408 \mu + 1.536 \mu^2) (t/L)^2} \right]$$

μ = Poisson's ratio

NOTE 1—The width (b) and thickness (t) values used in the modulus calculations (Eq 2 and 3) for the rectangular specimens will depend on the type of vibration (out-of-plane or in-plane) induced in the specimen. The cross-sectional dimension t will always be parallel to the vibrational motion. The dimension b will always be perpendicular to the vibrational motion. In effect, the two different flexural modes will give two different fundamental resonant frequencies, but the calculations for the two modes should give the same modulus value, because the values for b and t are exchanged in the calculations for the two different flexure modes.

NOTE 2—In the modulus equations, the mass and length terms are given in units of grams and millimetres. However, the defined equations can also be used with mass and length terms in units of kilograms and metres with no changes in terms or exponents.

10.1.1.1 If L/t ≥ 20, T₁ can be simplified to the following:

$$T_1 = [1.000 + 6.585 (t/L)^2] \tag{4}$$

and E can be calculated directly.