



Designation: D6706 – 01 (Reapproved 2021)

## Standard Test Method for Measuring Geosynthetic Pullout Resistance in Soil<sup>1</sup>

This standard is issued under the fixed designation D6706; the number immediately following the designation indicates the year of original adoption or, in the case of revision, the year of last revision. A number in parentheses indicates the year of last reapproval. A superscript epsilon ( $\epsilon$ ) indicates an editorial change since the last revision or reapproval.

### 1. Scope

1.1 Resistance of a geosynthetic to pullout from soil is determined using a laboratory pullout box.

1.2 The test method is intended to be a performance test conducted as closely as possible to replicate design or as-built conditions. It can also be used to compare different geosynthetics, soil types, etc., and thereby be used as a research and development test procedure.

1.3 The values stated in SI units are to be regarded as standard. The values stated in parentheses are provided for information only.

1.4 *This standard does not purport to address all of the safety concerns, if any, associated with its use. It is the responsibility of the user of this standard to establish appropriate safety, health, and environmental practices and determine the applicability of regulatory limitations prior to use.*

1.5 *This international standard was developed in accordance with internationally recognized principles on standardization established in the Decision on Principles for the Development of International Standards, Guides and Recommendations issued by the World Trade Organization Technical Barriers to Trade (TBT) Committee.*

### 2. Referenced Documents

#### 2.1 ASTM Standards:<sup>2</sup>

D123 Terminology Relating to Textiles

D653 Terminology Relating to Soil, Rock, and Contained Fluids

D3080 Test Method for Direct Shear Test of Soils Under Consolidated Drained Conditions

D4354 Practice for Sampling of Geosynthetics and Rolled Erosion Control Products (RECPs) for Testing

D4439 Terminology for Geosynthetics

<sup>1</sup> This test method is under the jurisdiction of ASTM Committee D35 on Geosynthetics and is the direct responsibility of Subcommittee D35.01 on Mechanical Properties.

Current edition approved Sept. 1, 2021. Published September 2021. Originally approved in 2001. Last previous edition approved in 2013 as D6706 – 01 (2013). DOI: 10.1520/D6706-01R21.

<sup>2</sup> For referenced ASTM standards, visit the ASTM website, [www.astm.org](http://www.astm.org), or contact ASTM Customer Service at [service@astm.org](mailto:service@astm.org). For *Annual Book of ASTM Standards* volume information, refer to the standard's Document Summary page on the ASTM website.

### 3. Terminology

#### 3.1 Definitions of Terms Specific to This Standard:

3.1.1 *apertures, n*—the open spaces in geogrids which enable soil interlocking to occur.

3.1.2 *atmosphere for testing geosynthetics, n*—air maintained at a relative humidity of  $60 \pm 10\%$  and a temperature of  $21 \pm 2^\circ\text{C}$  ( $70 \pm 4^\circ\text{F}$ ).

3.1.3 *cross-machine direction, n*—the direction in the plane of the geosynthetic perpendicular to the direction of manufacture.

3.1.4 *failure, n*—a defined point at which a material ceases to be functionally capable of its intended use.

3.1.5 *geosynthetic, n*—a planar product manufactured from polymeric material used with soil, rock, earth, or other geotechnical engineering related material as an integral part of a man-made project, structure, or system. (D4439)

3.1.6 *junction, n*—the point where geogrid ribs are interconnected in order to provide structure and dimensional stability.

3.1.7 *machine direction, n*—the direction in the plane of the geosynthetic parallel to the direction of manufacture.

3.1.8 *pullout, n*—the movement of a geosynthetic over its entire embedded length, with initial pullout occurring when the back of the specimen moves, and ultimate pullout occurring when the movement is uniform over the entire embedded length.

3.1.9 *pullout force, (kN), n*—force required to pull a geosynthetic out of the soil during a pullout test.

3.1.10 *pullout resistance, (kN/m), n*—the pullout force per width of geosynthetic measured at a specified condition of displacement.

3.1.11 *rib, n*—the continuous elements of a geogrid which are either in the machine or cross-machine direction as manufactured.

3.1.12 *ultimate pullout resistance, (kN/m), n*—the maximum pullout resistance measured during a pullout test.

3.1.13 *wire gauge, n*—a displacement gauge consisting of a non-extensible wire attached to the geosynthetic and monitored by connection to a dial extensometer or electronic displacement transducer.

3.2 For definitions of other terms used in this test method, refer to Terminologies D123, D653, and D4439.

**4. Summary of Test Method**

4.1 In this method, a geosynthetic is embedded between two layers of soil, horizontal force is applied to the geosynthetic, and the force required to pull the geosynthetic out of the soil is recorded.

4.2 Pullout resistance is obtained by dividing the maximum load by the test specimen width.

4.3 The test is performed while subjected to normal compressive stresses which are applied to the top soil layer.

4.4 A plot of maximum pullout resistance versus applied normal stress is obtained by conducting a series of such tests.

**5. Significance and Use**

5.1 The pullout test method is intended as a performance test to provide the user with a set of design values for the test conditions examined.

5.1.1 The test method is applicable to all geosynthetics and all soils.

5.1.2 This test method produces test data, which can be used in the design of geosynthetic-reinforced retaining walls, slopes, and embankments, or in other applications where resistance of a geosynthetic to pullout under simulated field conditions is important.

5.1.3 The test results may also provide information related to the in-soil stress-strain response of a geosynthetic under confined loading conditions.

5.2 The pullout resistance versus normal stress plot obtained from this test is a function of soil gradation, plasticity, as-placed dry unit weight, moisture content, length and surface characteristics of the geosynthetic, and other test parameters. Therefore, results are expressed in terms of the actual test conditions. The test measures the net effect of a combination of pullout mechanisms, which may vary depending on type of

geosynthetic specimen, embedment length, relative opening size, soil type, displacement rate, normal stress, and other factors.

5.3 Information between laboratories on precision is incomplete. In cases of dispute, comparative tests to determine if there is a statistical bias between laboratories may be advisable.

**6. Apparatus**

6.1 *Pullout Box*—An open rigid box consisting of two smooth parallel sides, a back wall, a horizontal split removable door, a bottom plate, and a load transfer sleeve. The door is at the front as defined by the direction of applied pullout force. A typical box is shown in Fig. 1.

6.1.1 The box should be square or rectangular with minimum dimensions 610 mm (24 in.) long by 460 mm (18 in.) wide by 305 mm (12 in.) deep, if sidewall friction is minimized, otherwise the minimum width should be 760 mm (30 in.). The dimensions should be increased, if necessary, so that minimum width is the greater of 20 times the D85 of the soil or six times the maximum soil particle size, and the minimum length greater than five times the maximum geosynthetic aperture size. The box shall allow for a minimum depth of 150 mm (6 in.) above and below the geosynthetic. The depth of the soil in the box above or below the geosynthetic shall be a minimum of six times the D85 of the soil or three times the maximum particle size of the soil, whichever is greater. The box must allow for at least 610 mm (24 in.) embedment length beyond the load transfer sleeve and a minimum specimen length to width ratio of 2.0. It should be understood that when testing large aperture geosynthetics the actual pullout box may have to be larger than the stated minimum dimensions.

NOTE 1—To remove sidewall friction as much as possible, a high-density polyethylene (HDPE) geomembrane should be bonded to the inside surfaces of the pullout box. The sidewalls may also be covered with a layer of silk fabric, which has been shown to eliminate adhesion and has a very low friction value. Alternatively, a lubricant can be spread on the

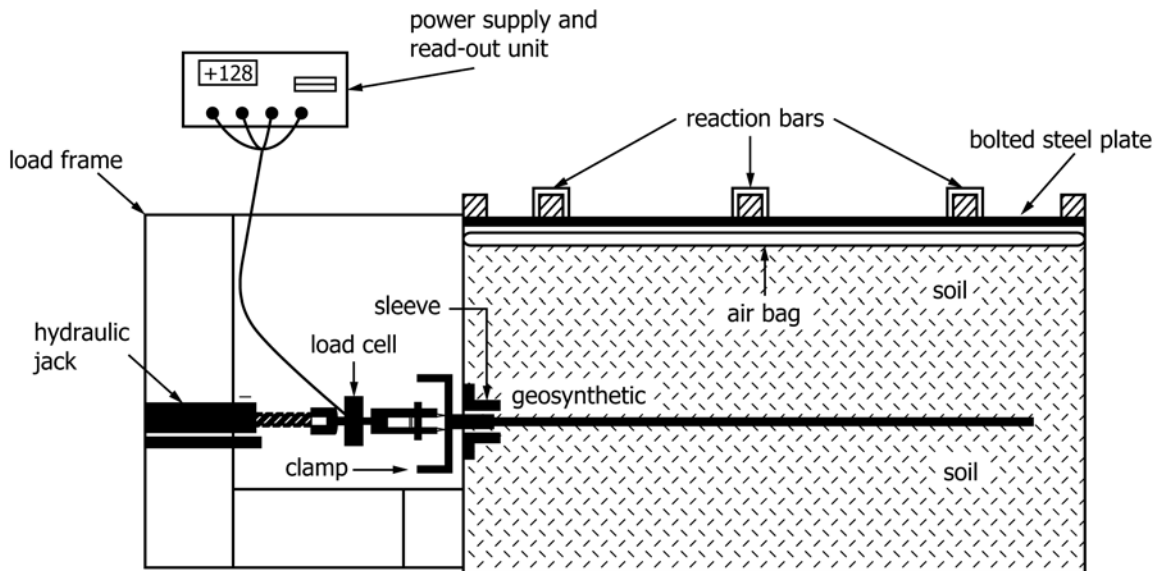

FIG. 1 Experimental Setup for Geosynthetic Pullout Testing

sidewalls of the box and thin sheets of polyethylene film used to minimize the sidewall friction. It should be also noted that the effect of sidewall friction on the soil-geosynthetic interface can also be eliminated if a minimum distance is kept between the specimen and the sidewall. This minimum distance is recommended to be 150 mm (6 in.).

6.1.2 The box shall be fitted with a metal sleeve at the entrance of the box to transfer the force into the soil to a sufficient horizontal distance so as to significantly reduce the stress on the door of the box. The sleeve, as shown in Fig. 2, shall consist of two thin plates (no more than 13 mm (0.5 in.) thick) extending the full width of the pullout box and into the pullout box a minimum distance of 150 mm (6 in.) but it is recommended that this distance equal the total soil depth above or below the geosynthetic. The plates shall be tapered as shown in Fig. 2, such that at the point of load application in the soil, the plates forming the sleeve are no more than 3 mm (0.12 in.) thick. The plates shall be rigidly separated at the sides with spacers and be sufficiently stiff such that normal stress is not transferred to the geosynthetic between the plates.

6.2 Normal Stress Loading Device—Normal stress applied to the upper layer of soil above the geosynthetic must be constant and uniform for the duration of the test. To maintain a uniform normal stress, a flexible pneumatic or hydraulic diaphragm-loading device which is continuous over the entire pullout box area should be used and capable of maintaining the applied normal stress within  $\pm 2\%$  of the required normal stress. Normal stresses utilized will depend on testing requirements; however, stresses up to 250 kPa (35 psi) should be anticipated. A recommended normal stress-loading device is an air bag as shown in Fig. 2.

6.3 Pullout Force Loading Device—Pullout force must be supplied by a device with the ability to pull the geosynthetic horizontally out of the pullout box. The force must be at the same level with the specimen. The pullout system must be able to apply the pullout force at a constant rate of displacement, slow enough to dissipate soil pore pressures as outlined in Test Method D3080. If excess pore pressures are not anticipated and in the absence of a material specification, apply the pullout force at a rate of 1 mm/min  $\pm 10\%$ , and the pullout rate should be monitored during testing; see Note 2. Also, a device to measure the pullout force such as a load cell or proving ring must be incorporated into the system and shall be accurate within  $\pm 0.5\%$  of its full-scale range.

NOTE 2—Pullout tests may also be conducted using a constant stress loading approach. This approach can be achieved using one of the three methods described: (1) controlled stress rate method (short-term loading condition) where the pullout force is applied to the geosynthetic under a uniform rate of load application, not exceeding 2 kN/m/min until pullout or failure of the geosynthetic is achieved; (2) incremental stress method (short-term loading condition) where the pullout force is applied in uniform or doubling increments and held for a specific time before proceeding to the next increment, as agreed to by the parties involved until pullout or failure of the geosynthetic is achieved; and (3) constant stress (creep) method (long-term loading condition) where the pullout force is applied using one of the first two methods mentioned above to achieve the required constant stress for the test. The constant stress is maintained and the test specimen is monitored over time for the duration of time agreed to by the parties involved (i.e., typically 100 to 10 000 h depending on application). It should be noted that the constant stress procedures described above have not been widely researched and comparisons with the constant strain method have not been determined.

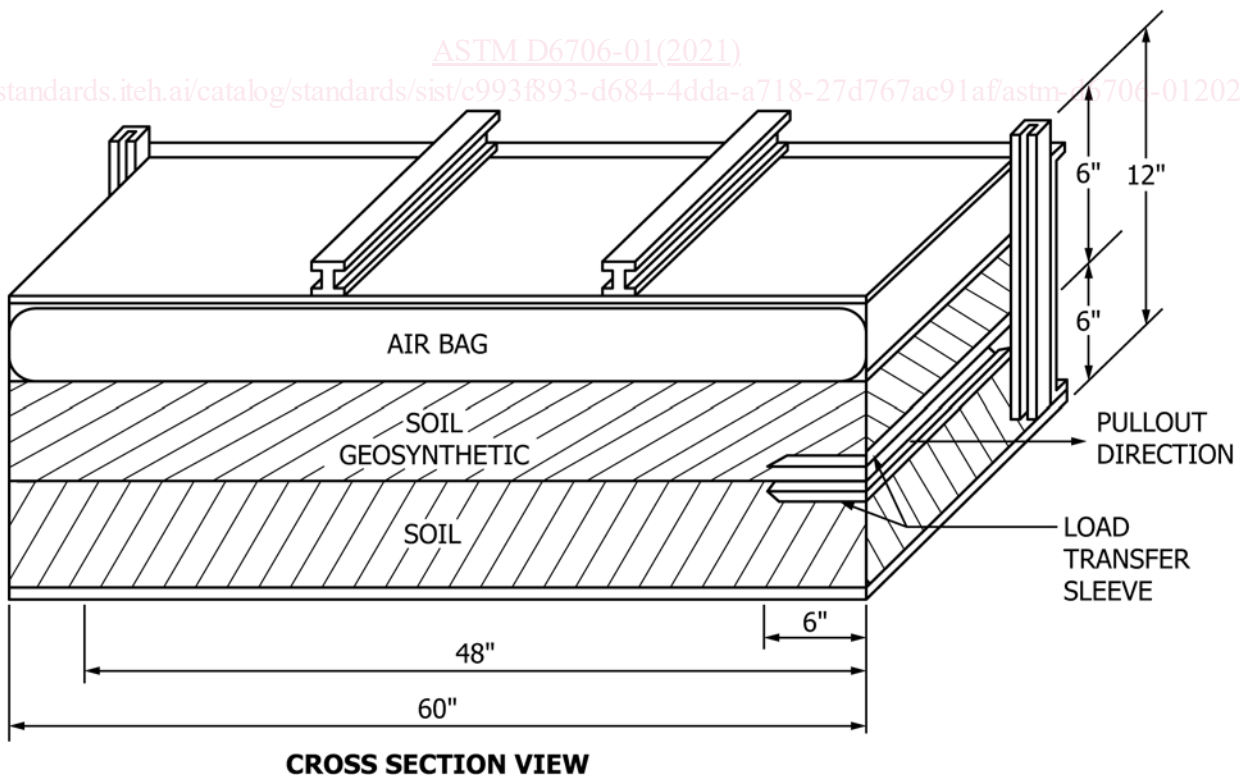

FIG. 2 Cross-Sectional Detail View for Geosynthetic Pullout Setup

6.4 *Displacement Indicators*—Horizontal displacement of the geosynthetic is measured at the entrance of the pullout box and at several locations on the embedded portion of the specimen. Measurements outside the door at the pullout box entrance are made by a dial extensometer or electronic displacement transducers (e.g. liner variable differential transformers (LVDTs) can be used) mounted to the box frame to read against a plate attached to the specimen near the door.

6.4.1 Determine the displacement of the geosynthetic at a minimum of three equally spaced distances from the clamping plates. Displacement measurements within the box may employ any of several methods, which place sensors or gauge connectors directly on the geosynthetic and monitor their change in location remotely. One such device utilizes wire gauges, which are protected from normal stress by a surrounding tube, which runs from a location mounted on the specimen to the outside of the box where displacements are measured by a dial indicator or electronic displacement transducer. A typical instrumentation setup is shown in Fig. 3.

6.4.2 All dial gauges or electronic measurement devices must be accurate to  $\pm 0.10$  mm. Locations of the devices must be accurately determined and recorded. Minimum extension capabilities of 50 mm (2 in.) are recommended.

6.5 *Geosynthetic Clamping Devices*—Clamps which connect the specimen to the pullout force system without slipping, causing clamp breaks, or weakening the material may be used; see Note 3. The clamps shall be swiveled to allow the pulling forces to be distributed evenly throughout the width of the sample. The clamps must allow the specimen to remain horizontal during loading and not interfere with the pullout/shear surface. Gluing, bonding, or otherwise molding of a geosynthetic within the clamp area is acceptable and recommended whenever slippage might occur.

NOTE 3—A suggested device is shown in Fig. 4 and includes a simple clamp consisting of two 100 mm (4 in.) wide metal angle pieces with a series of bolts and nuts holding the material between them. One possible

modification is the addition of a metal rod behind the back flange which allows looping of the material around the rod and back into the clamp. The use of epoxy bonding within the clamp is generally recommended when accurate measurement of the geosynthetic displacements within the soil are required.

6.6 *Soil Preparation Equipment*—Use equipment as necessary for the placement of soils at desired conditions. This may include compaction devices such as vibratory or “jumping-jack” type compaction, or hand compaction hammers. Soil container or hopper, leveling tools, and soil placement/removal tools may be required.

6.7 *Miscellaneous Equipment*—Measurement and trimming equipment as necessary for geosynthetic preparation, a timing device, and soil property testing equipment if desired.

## 7. Geosynthetic Sampling

7.1 *Lot Sample*—Divide the product into lots and for any lot to be tested, take the lot samples as directed in Practice D4354; see Note 4.

NOTE 4—Lots of geosynthetics are usually designated by the producer during manufacture. While this test method does not attempt to establish a frequency of testing for determination of design oriented data, the lot number of the laboratory sample should be identified. The lot number should be unique to the raw material and manufacturing process for a specific number of units (for example, rolls, panel, etc.) designated by the producer.

7.2 *Laboratory Sample*—Consider the units in the lot sample as the units in the laboratory sample for the lot to be tested. Take for a laboratory sample, a sample extending the full width of the geosynthetic production unit, of sufficient length along the selvage or edge from each sample roll so that the requirement of 7.3 can be met. Take a sample that will exclude material from the outer wrap unless the sample is taken at the production site, at which point inner and outer wrap material may be used.

7.3 *Test Specimens*—For each unit in the laboratory sample, remove the required number of specimens. In the absence of a

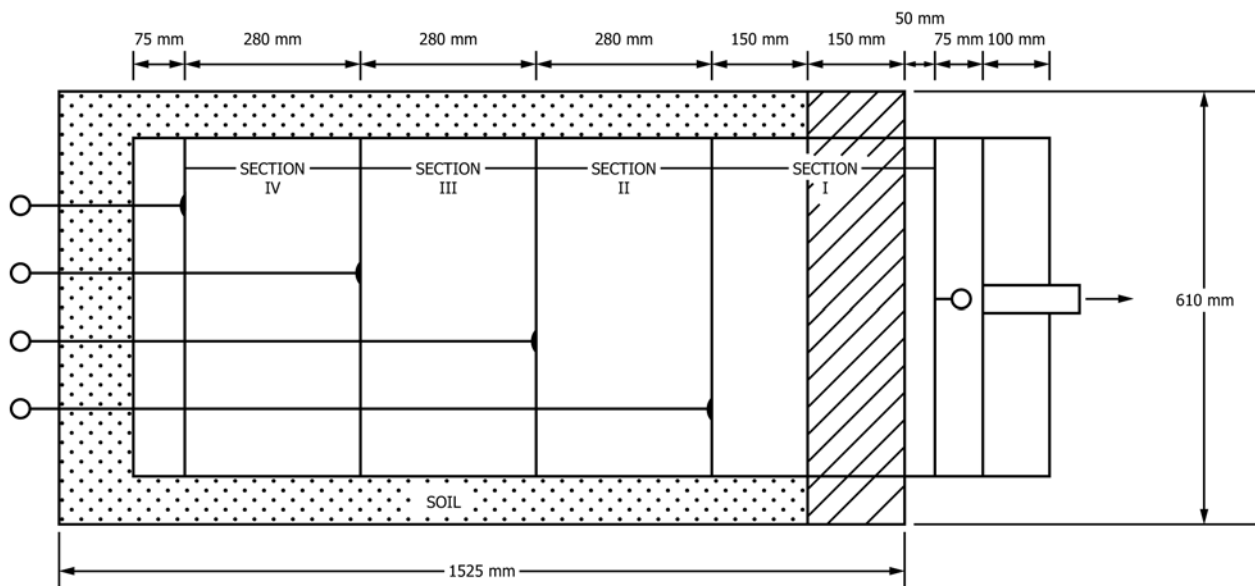

FIG. 3 Plan View and Typical “Tell-Tale” Gauge Layout

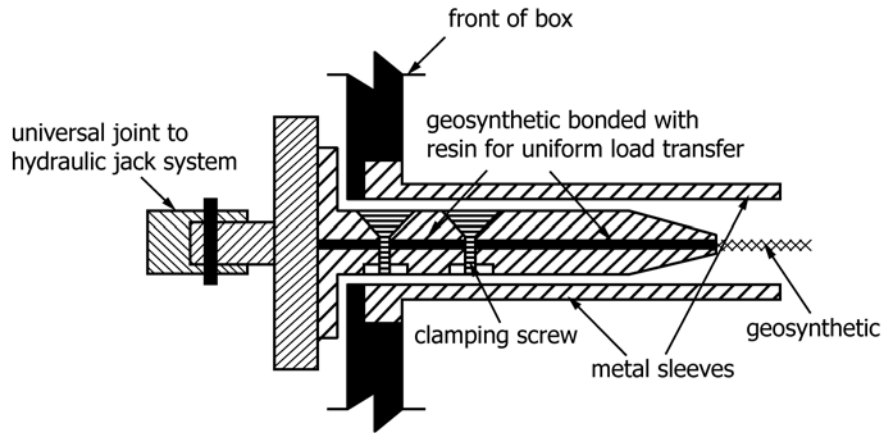

FIG. 4 Geosynthetic Pullout Clamping Detail

material specification, select a minimum of three specimens if pullout force versus normal stress relations are to be established.

7.3.1 Remove the minimum of specimens for pullout testing in a required direction; see Note 5. The minimum embedded test specimen shall have dimensions of 610 mm (24 in.) long by 305 mm (12 in.) wide. The actual size of the test specimen must allow for a minimum of 75 mm (3 in.) clearance on each side of the test specimen from the sidewalls of the pullout box if the sidewall friction is minimized (see Note 1); otherwise, the minimum clearance should be 150 mm (6 in.) on each side. The length of the test specimen shall be of sufficient size to facilitate clamping and maintain the minimum length to width ratio of 2. The minimum width of the test specimen shall be 305 mm (12 in.) and should include a minimum of five tensile elements (i.e., ribs/strands). All specimens should be free of surface defects, etc., not typical of the laboratory sample. Take no specimens nearer the selvage edge of the geosynthetic production unit than  $\frac{1}{10}$  the width of the unit.

NOTE 5—The pullout characteristics of some geosynthetics may depend on the direction tested. In some applications, it may be necessary to perform pullout tests in both the machine and the cross-machine directions. In all cases, the direction of pullout of the geosynthetic specimen(s) should be clearly noted.

## 8. Conditioning

8.1 When soil is included in the test specimen, the method of conditioning is selected by the user or mutually agreed upon by the user and testing agency. In the absence of specified conditioning criteria, the test should be performed in the atmosphere for testing geotextiles defined in 3.1.2.

8.2 When the geosynthetic is to be tested in the wet condition, saturate the specimen in water for a minimum of 24 h prior to testing; see Note 6.

NOTE 6—Geosynthetics which do not absorb measurable quantities of water, such as some geomembranes, geogrids, and geonets, may not require a full 24-h saturation period for the purpose of this test.

## 9. Procedure

9.1 *Prepare Pullout Box*—Assemble pullout box with only the bottom half of the door in place. Determine the amount of soil necessary to achieve the desired dry unit weight of the soil

when placed in the lower half of the pullout box. The bottom layer of soil should be slightly above the bottom half of the door (approximately 10 mm (0.4 in.)) to avoid dragging of the geosynthetic on the door. The calculated amount of soil is placed in the bottom section of the box and compacted as required. The required number of lifts and amount of compactive effort to be used is a function of the soil type and moisture content, and should be noted. The soil placement procedure that is used should allow for a uniform soil dry unit weight along the pullout box. Level the soil surface. The front section of soil should be excavated such that the bottom part of the metal sleeve can be placed with the upper surface horizontal and level with the soil.

9.2 *Place Geosynthetic*—Obtain a test specimen as described in Section 7. Trim the specimen to fit loosely inside the pullout box with a minimum of 75 mm (3 in.) between the edge of the specimen and the edge of the pullout box parallel to the direction of pull, if sidewall friction is minimized (see Note 1); otherwise, there should be a minimum of 150 mm (6 in.) between the edge of the specimen and the side of the pullout box. Clamp the sample outside the entrance of the box, gluing or preparing area in clamp as necessary for uniform pressure, without damaging the sample. Connect sample and clamp to pullout force device. Place the geosynthetic within the metal sleeve at the box entrance. Attach the dial gauge or electronic displacement transducer to pullout clamp outside of the pullout box.

9.2.1 Next, the in-soil displacement devices are installed. Connect the gauges to the specimen and measure locations of gauges relative to the door. The gauges should be evenly spaced along the length of the specimen on a diagonal across the width of the specimen, see Fig. 3. Wire gauges can be attached by hooking wire to a glued-on tab or, in the case of geogrids, tying directly on to the specimen. Care must be taken to ensure any slack in the wire is eliminated.

9.3 *Embed the Geosynthetic*—Install top metal sleeve and top half of door positioned above the test specimen at the entrance of the pullout box. Place the desired amount of soil on top of geosynthetic to the required level (see 6.1). Use the same placement method as used for the bottom soil layer; see 9.1.