



Standard Specification for Valve Locking Devices¹

This standard is issued under the fixed designation F993; the number immediately following the designation indicates the year of original adoption or, in the case of revision, the year of last revision. A number in parentheses indicates the year of last reapproval. A superscript epsilon (ϵ) indicates an editorial change since the last revision or reapproval.

This standard has been approved for use by agencies of the U.S. Department of Defense.

1. Scope

1.1 This specification² covers the application, design, and materials for valve locking devices.

1.2 Locking devices Types I and II described in this specification are designed to secure the valve in a fully opened or completely closed position.

1.3 This specification does not apply to valves equipped with locking devices from the valve manufacturer, unless this standard is invoked in the procurement ordering data for the valve or its locking device, or both.

1.4 The values stated in inch-pound units are to be regarded as standard. No other units of measurement are included in this standard.

1.5 *This international standard was developed in accordance with internationally recognized principles on standardization established in the Decision on Principles for the Development of International Standards, Guides and Recommendations issued by the World Trade Organization Technical Barriers to Trade (TBT) Committee.*

2. Referenced Documents

2.1 ASTM Standards:³

- [A36/A36M Specification for Carbon Structural Steel](#)
- [A240 Specification for Chromium and Chromium-Nickel Stainless Steel Plate, Sheet, and Strip for Pressure Vessels and for General Applications](#)
- [A492 Specification for Stainless Steel Rope Wire](#)
- [A668/A668M Specification for Steel Forgings, Carbon and Alloy, for General Industrial Use](#)

- [B209 Specification for Aluminum and Aluminum-Alloy Sheet and Plate \(Metric\) B0209_B0209M](#)
- [B580 Specification for Anodic Oxide Coatings on Aluminum](#)
- [F708 Practice for Design and Installation of Rigid Pipe Hangers](#)
- 2.2 *Other Documents:*
 - [ASME B18.1.1 Small Solid Rivets 7/16 Inch Nominal Diameter and Smaller⁴](#)
 - [AWS D1.1 on Steel⁵](#)

3. Classification

3.1 Valve locking devices shall be classified by the following types and grades in accordance with the method of locking and material used.

3.2 Types:

- 3.2.1 *Type I*—Wire rope assembly (see [Fig. 1](#) and [Fig. 2](#)).
- 3.2.2 *Type II*—Handwheel latch (see [Fig. 3](#) and [Fig. 4](#)).
- 3.2.3 *Type III*—Locking shield (see [Fig. 5](#)).

3.3 Grades:

- 3.3.1 *Grade A*—Stainless steel, Specification [A240](#), Type 316.
- 3.3.2 *Grade B*—Anodized aluminum, Specification [B209](#), Alloy 5052.
- 3.3.3 *Grade C*—Carbon steel, commercial quality steel (see Specification [A36/A36M](#)).

4. Ordering Information

- 4.1 Orders for material under this specification shall include the following:
 - 4.2 ASTM Designation and year of issue.
 - 4.3 *Type*.
 - 4.4 *Grade*.
 - 4.5 *Padlock Size* (if necessary).
 - 4.6 *Rubber Coating* (if necessary).

¹ This specification is under the jurisdiction of ASTM Committee F25 on Ships and Marine Technology and is the direct responsibility of Subcommittee F25.11 on Machinery and Piping Systems.

Current edition approved Sept. 1, 2021. Published September 2021. Originally approved in 1986. Last previous edition approved in 2017 as F993 – 17. DOI: 10.1520/F0993-21.

² This specification was developed to supersede NAVSEA Drawing S4824-1385509, which has subsequently been cancelled and this specification has been approved for use by agencies of the U.S. Department of Defense.

³ For referenced ASTM standards, visit the ASTM website, www.astm.org, or contact ASTM Customer Service at service@astm.org. For *Annual Book of ASTM Standards* volume information, refer to the standard's Document Summary page on the ASTM website.

⁴ Available from American Society of Mechanical Engineers (ASME), ASME International Headquarters, Two Park Ave., New York, NY 10016-5990, <http://www.asme.org>.

⁵ Available from American Welding Society (AWS), 8669 NW 36 St., #130, Miami, FL 33166-6672, <http://www.aws.org>.

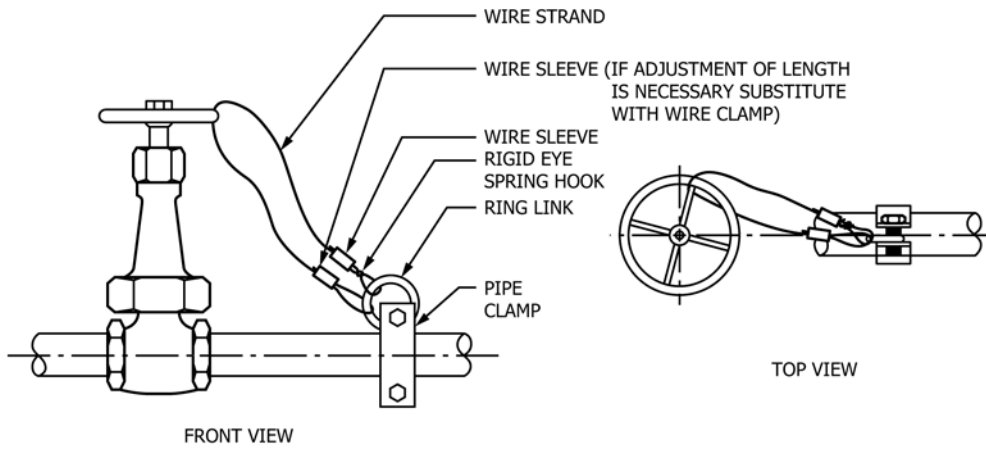
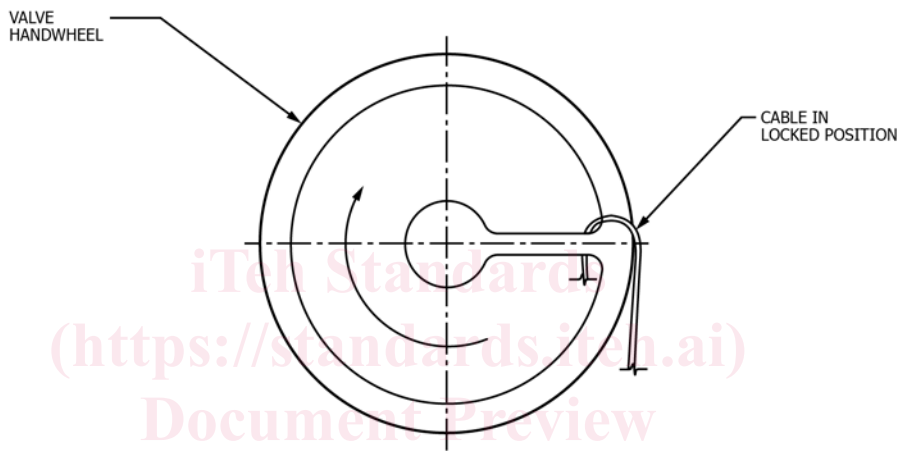

FIG. 1 Type I—Wire Rope Assembly



(a) Handwheel locked in maximum position clockwise rotation

ASTM F993-21

<https://standards.iteh.ai/catalog/standards/sist/a2cd4bd6-7e0b-41be-a559-16af7a22d8bc/astm-f993-21>

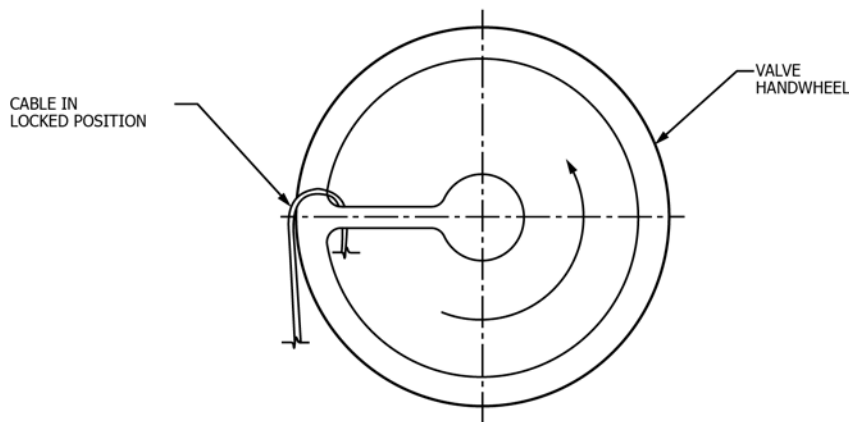

(b) Handwheel locked in maximum position counterclockwise rotation

FIG. 2 Miscellaneous Type I Details

4.7 Necessary Dimensions:

4.7.1 Type I:

- 4.7.1.1 Length of wire strand.
- 4.7.1.2 Diameter of pipe.

4.7.2 Type II:

- 4.7.2.1 Maximum height (fully opened).
- 4.7.2.2 Minimum height (fully closed).
- 4.7.2.3 Handwheel thickness.

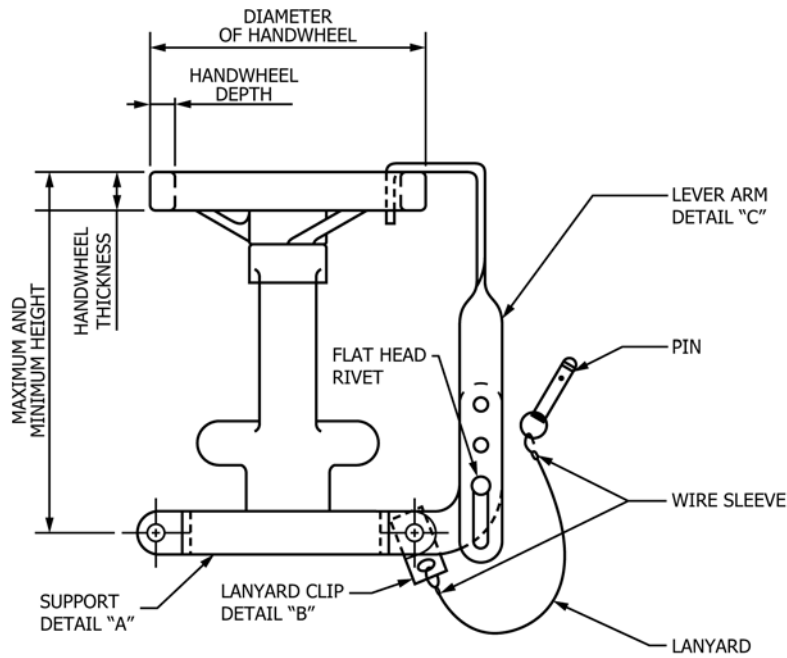

FIG. 3 Type II—Handwheel Latch

- 4.7.2.4 Handwheel depth.
- 4.7.2.5 Diameter at location of attachment.
- 4.7.3 *Type III*:
- 4.7.3.1 Depth.
- 4.7.3.2 Height.
- 4.7.3.3 Width.
- 4.7.3.4 Outside diameter (OD) of pipe.

5. Materials and Manufacture

5.1 Materials:

5.1.1 *Type I* Materials:

5.1.1.1 *Pipe Clamp*—Indicate diameter, similar to Practice F708, Fig. 1, material specified by grade.

5.1.1.2 *Ring Link*—Size to be not less than clearance shown in Practice F708, Table 3, Column F, material specified by grade.

5.1.1.3 *Common Wire Strand*— $\frac{3}{16}$ -in. diameter, seven strands of seven wires each, stainless steel, Specification A492, Alloy 316.

5.1.1.4 *Tiller Rope Clamp*— $\frac{3}{16}$ -in. cable size, manufacturer, stainless steel (optional).

5.1.1.5 *Rigid Eye Spring Hook*— $\frac{5}{8}$ -in. eye diameter, $\frac{1}{2}$ -in. snap opening, plated forged steel, Specification A668/A668M, Class D.

5.1.1.6 *Sleeve*—Swaging, oval, for $\frac{3}{16}$ -in. diameter wire rope, copper.

5.1.2 *Type II* Materials:

5.1.2.1 *Modified Pipe Clamp*—Indicate diameter, similar to Practice F708, Fig. 1, material specified by grade.

5.1.2.2 *Flat Head Rivet*— $\frac{1}{4}$ -in. nominal size, ASME B18.1.1, material specified by grade.

5.1.2.3 *Single Acting Quick Release Pin*— $\frac{1}{4}$ -in. nominal size by $\frac{5}{10}$ -in. grip, stainless steel, Specification A240, Type 316.

5.1.2.4 *Lanyard*—Wire rope, $\frac{1}{8}$ -in. diameter, seven strands of seven wires each, 12 in. long, stainless steel Specification A492, Alloy 316.

5.1.2.5 *Sleeve*—Swaging, oval, for $\frac{1}{8}$ -in. diameter wire rope, copper.

5.1.2.6 *Lanyard Clip*—Flatbar, $\frac{1}{16}$ in. thick by 1 in. wide by $1\frac{1}{2}$ in. long, stainless steel, Specification A240, Alloy 316.

5.1.2.7 *Lever Arm*—Size to suit, 16-gauge material specified by grade.

5.1.3 *Type III* Materials:

5.1.3.1 *Plate*—Indicate size, 16 gauge, material specified by grade.

5.1.3.2 *Single-Acting Quick Release Pin*— $\frac{1}{4}$ -in. nominal size by $\frac{1}{2}$ -in. grip, stainless steel, Specification A240, Type 316.

5.1.3.3 *Lanyard*—Wire rope, $\frac{1}{8}$ -in. diameter, seven strands of seven wires each, 12 in. long, stainless steel, Specification A492, Alloy 316.

5.1.3.4 *Sleeve*—Swaging, oval, for $\frac{1}{8}$ -in. diameter wire rope, copper.

5.1.3.5 *Lanyard Clip*—Flatbar, $\frac{1}{16}$ in. thick by 1 in. wide by $1\frac{1}{2}$ in. long, stainless steel, Specification A240, Alloy 316.

5.1.3.6 *Lockbar*— $\frac{7}{8}$ in. wide by length to suit by $\frac{1}{16}$ in. thick, material specified by grade.

5.2 Manufacture:

5.2.1 Edges of the locking device shall be smooth. The devices shall also be free of defects and burrs.

5.2.2 Welds shall be done in accordance with AWS D1.1.

6. General Requirements

6.1 A label plate shall be installed on or near the locking device to instruct the operator on usage.