



Standard Test Method for Specific Optical Density of Smoke Generated by Solid Materials¹

This standard is issued under the fixed designation E662; the number immediately following the designation indicates the year of original adoption or, in the case of revision, the year of last revision. A number in parentheses indicates the year of last reapproval. A superscript epsilon (ϵ) indicates an editorial change since the last revision or reapproval.

This standard has been approved for use by agencies of the U.S. Department of Defense.

^{ε1} NOTE—In 7.1.2.1(2), the temperature tolerance was corrected to 5 °F and in Note 2, the degree symbol was removed from °K in September 2021.

1. Scope*

1.1 This fire-test-response standard covers determination of the specific optical density of smoke generated by solid materials and assemblies mounted in the vertical position in thicknesses up to and including 1 in. (25.4 mm).

1.2 Measurement is made of the attenuation of a light beam by smoke (suspended solid or liquid particles) accumulating within a closed chamber due to nonflaming pyrolytic decomposition and flaming combustion.

1.3 Results are expressed in terms of specific optical density which is derived from a geometrical factor and the measured optical density, a measurement characteristic of the concentration of smoke.

1.4 The values stated in inch-pound units are to be regarded as standard. The values given in parentheses are mathematical conversions to SI units that are provided for information only and are not considered standard.

1.5 *This standard measures and describes the response of materials, products, or assemblies to heat and flame under controlled conditions, but does not by itself incorporate all factors required for fire hazard or fire risk assessment of the materials, products or assemblies under actual fire conditions.*

1.6 *This standard does not purport to address all of the safety concerns, if any, associated with its use. It is the responsibility of the user of this standard to establish appropriate safety, health, and environmental practices and determine the applicability of regulatory limitations prior to use.*

1.7 *This international standard was developed in accordance with internationally recognized principles on standardization established in the Decision on Principles for the Development of International Standards, Guides and Recom-*

mendations issued by the World Trade Organization Technical Barriers to Trade (TBT) Committee.

2. Referenced Documents

2.1 *ASTM Standards:*²

[C1186 Specification for Flat Fiber-Cement Sheets](#)

[C1288 Specification for Fiber-Cement Interior Substrate Sheets](#)

[D2843 Test Method for Density of Smoke from the Burning or Decomposition of Plastics](#)

[E176 Terminology of Fire Standards](#)

[E662 Test Method for Specific Optical Density of Smoke Generated by Solid Materials](#)

2.2 *ANSI/AHA:*³

[A135.4 Basic Hardboard](#)

3. Terminology

3.1 *Definitions*—For definitions of terms found in this test method refer to Terminology [E176](#).

4. Summary of Test Method

4.1 This test method employs an electrically heated radiant-energy source mounted within an insulated ceramic tube and positioned so as to produce an irradiance level of 2.2 Btu/s-ft² (2.5 W/cm²) averaged over the central 1.5-in. (38.1 mm) diameter area of a vertically mounted specimen facing the radiant heater. The nominal 3 by 3-in. (76.2 by 76.2 mm) specimen is mounted within a holder which exposes an area measuring 2⁹/₁₆ by 2⁹/₁₆ in. (65.1 by 65.1 mm). The holder is able to accommodate specimens up to 1 in. (25.4 mm) thick. This exposure provides the nonflaming condition of the test.

¹ This test method is under the jurisdiction of ASTM Committee E05 on Fire Standards and is the direct responsibility of Subcommittee E05.21 on Smoke and Combustion Products.

Current edition approved June 1, 2021. Published June 2021. Originally approved in 1979. Last previous edition approved in 2021 as E662 – 21. DOI: 10.1520/E0662-21AE01.

² For referenced ASTM standards, visit the ASTM website, www.astm.org, or contact ASTM Customer Service at service@astm.org. For *Annual Book of ASTM Standards* volume information, refer to the standard's Document Summary page on the ASTM website.

³ American Hardboard Association, 1210 West Northwest Highway, Palatine, IL 60067, United States.

*A Summary of Changes section appears at the end of this standard

4.2 For the flaming condition, a six-tube burner is used to apply a row of equidistant flamelets across the lower edge of the exposed specimen area and into the specimen holder trough. This application of flame in addition to the specified irradiance level from the heating element constitutes the flaming combustion exposure.

4.3 The test specimens are exposed to the flaming and nonflaming conditions within a closed chamber. A photometric system with a vertical light path is used to measure the varying light transmission as smoke accumulates. The light transmittance measurements are used to calculate specific optical density of the smoke generated during the time period to reach the maximum value.⁴

5. Significance and Use

5.1 This test method provides a means for determining the specific optical density of the smoke generated by specimens of materials and assemblies under the specified exposure conditions. Values determined by this test are specific to the specimen or assembly in the form and thickness tested and are not to be considered inherent fundamental properties of the material tested. Thus, it is likely that closely repeatable or reproducible experimental results are not to be expected from tests of a given material when specimen thickness, density, or other variables are involved.

5.2 The photometric scale used to measure smoke by this test method is similar to the optical density scale for human vision. However, physiological aspects associated with vision are not measured by this test method. Correlation with measurements by other test methods has not been established.⁵

5.3 At the present time no basis is provided for predicting the density of smoke generated by the materials upon exposure to heat and flame under other fire conditions.

5.4 The test method is of a complex nature and the data obtained are sensitive to variations which in other test methods might be considered to be insignificant (see Section 6). A precision statement based on the results of a round-robin test by a prior draft version of this test method is given in 14.1.

5.5 In this procedure, the specimens are subjected to one or more specific sets of laboratory test conditions. If different test conditions are substituted or the end-use conditions are changed, it is not always possible by or from this test method to predict changes in the fire-test-response characteristics measured. Therefore, the results are valid only for the fire test exposure conditions described in this procedure.

6. Limitations

6.1 If during the test of one or more of the three replicate samples there occurs such unusual behavior as (1) the speci-

men falling out of the holder, (2) melted material overflowing the sample holder trough, (3) self-ignition in the pyrolysis mode, (4) extinguishment of the flame triplets (even for a short period of time), or (5) a specimen being displaced from the zone of controlled irradiance, then an additional three samples of the identical preconditioned materials shall be tested in the test mode in which the unusual behavior occurred. Data obtained from the improper tests noted above shall not be incorporated in the averaged data but the occurrence shall be reported. The test method is not suitable if more than three of the six replicates tested show these characteristics.

6.2 The test method has proven sensitive to small variations in sample geometry, surface orientation, thickness (either overall or individual layer), weight, and composition. It is, therefore, critical that the replicate samples be cut, sawed, or blanked to identical sample areas, 3 by 3, +0, -0.03 in. (76.2 by 76.2, +0, -0.8 mm), and that records be kept of the respective weights with the individual test data. It is feasible that evaluation of the obtained data together with the individual weights will assist in assessing the reasons for any observed variability in measurements. Preselection of samples with identical thickness or weight, or both, are potential methods to reduce the variability but are likely to not be truly indicative of the actual variability to be expected from the material as normally supplied.

6.3 The results of the test apply only to the thickness of the specimen as tested. There is no common mathematical formula to calculate the specific optical density of one thickness of a material when the specific optical density of another thickness of the same material is known.

6.4 The test method is sensitive to small variations of the position of the specimen and radiometer relative to the radiant heat source.

6.5 It is critical to clean the test chamber, and to remove accumulated residues from the walls when changing from one test material to another, to ensure that chemical or physical recombination with the effluents or residues produced does not affect the data obtained. Even when testing the same material, excessive accumulations of residue shall not be permitted to build up since ruggedness tests have indicated that such accumulations serve as additional insulators tending to reduce normally expected condensation of the aerosol, thereby raising the measured specific optical density.

6.6 With resilient samples, take extreme care to ensure that each replicate sample in its aluminum foil wrapper is installed so that each protrudes identically through the front sample holder opening. Unequal protrusion will subject the samples to different effective irradiances and to slightly different ignition exposures. Excessive protrusion of specimens has the potential to cause drips or for the specimen to sag onto the burner, clogging the flame jets and thereby invalidating the test.

6.7 The measurements obtained have also proven sensitive to small differences in conditioning (see Section 9). Many materials such as carpeting and thick sections of wood, plastics, or plywood require long periods to attain equilibrium (constant weight) even in a forced-draft humidification chamber.

⁴ Additional parameters, such as the maximum rate of smoke accumulation, time to a fixed optical density level, or a smoke obscuration index provide potentially useful information. See Appendix X1.

⁵ Other test methods for measuring smoke available at the time of the publications referenced have been reviewed and summarized in "The Control of Smoke in Building Fires—A State of the Art Review." *Materials Research and Standards*, Vol 42, April 1971, pp. 16–23 and "A Report on Smoke Test Methods," *ASTM Standardization News*, August 1976, pp. 18–26.

7. Apparatus

7.1 Fig. 1 shows examples of the test apparatus, with a detailed description contained in the remainder of Section 7 and in Annex A2. The apparatus shall include the following:

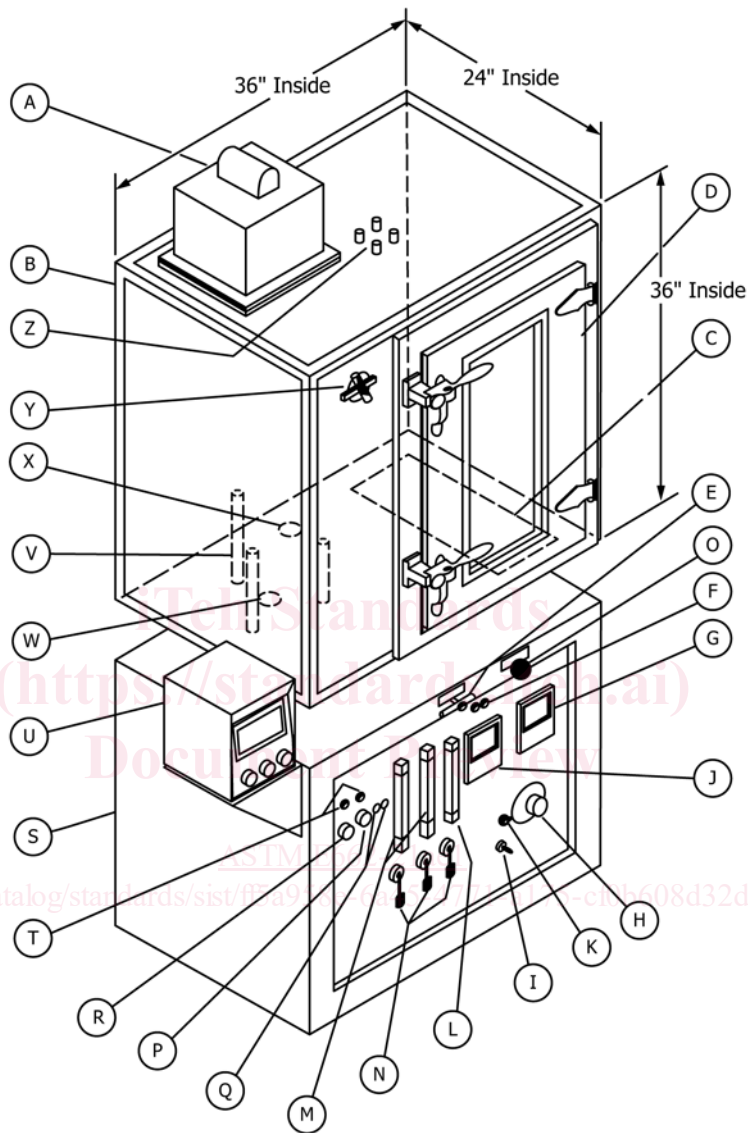

- | | |
|--|-------------------------------------|
| A—Photomultiplier tube housing | N—Flowmeter shutoff valves |
| B—Chamber | O—Sample mover knob |
| C—Blow-out panel (in floor of chamber) | P—Light source switch |
| D—Hinged door with window | Q—Light source voltage jacks |
| E—Exhaust vent control | R—Line switch |
| F—Radiometer output jacks | S—Base cabinet |
| G—Temperature (wall) indicator | T—Indicating lamps |
| H—Autotransformer | U—Microphotometer (photomultiplier) |
| I—Furnace switch | V—Optical system rods |
| J—Voltmeter (furnace) | W—Optical system floor window |
| K—Fuse holder (furnace) | X—Exhaust vent damper |
| L—Radiometer air flowmeter | Y—Inlet vent damper |
| M—Gas and air (burner) flowmeter | Z—Access ports |

FIG. 1 Smoke Density Chamber Assembly

7.1.1 *Test Chamber*—As shown in Fig. 1, the test chamber shall be fabricated from laminated panels⁶ to provide inside dimensions of 36 by 24 by 36 ± 1/8 in. (914 by 610 by 914 ± 3 mm) for width, depth, and height, respectively. The interior surfaces shall consist of porcelain enameled metal, or other coated metal, which shall be resistant to chemical attack and corrosion, and suitable for periodic cleaning. Sealed windows shall be provided to accommodate a vertical photometric system. All other chamber penetrations shall be sealed. When all openings are closed, the chamber shall be capable of developing and maintaining positive pressure during test

periods, in accordance with 11.12. The air-tightness of the chamber shall be tested at least one per test day in accordance with 11.2.

7.1.1.1 If the interior wall surfaces become corroded or the coating starts to peel off, users shall repair the damaged area using any suitable coating material, installed to the coating manufacturer's instructions.

NOTE 1—Some high temperature paints have been found satisfactory for this purpose.

7.1.1.2 Fit the chamber with a safety blow-out panel, consisting of a sheet of aluminum foil of thickness not greater than 1.63×10^{-3} in. (0.04 mm) and having a minimum area of 125 in.² (80 600 mm²), fastened in such a way as to provide an airtight seal.

7.1.2 *Radiant Heat Furnace*—As shown in Fig. 2, an

⁶ Commercially available panels of porcelain-enameled steel (interior surface) permanently laminated to an asbestos-magnesia core and backed with galvanized steel (exterior surface), total thickness 3/16 in. (9.6 mm), have been found suitable.

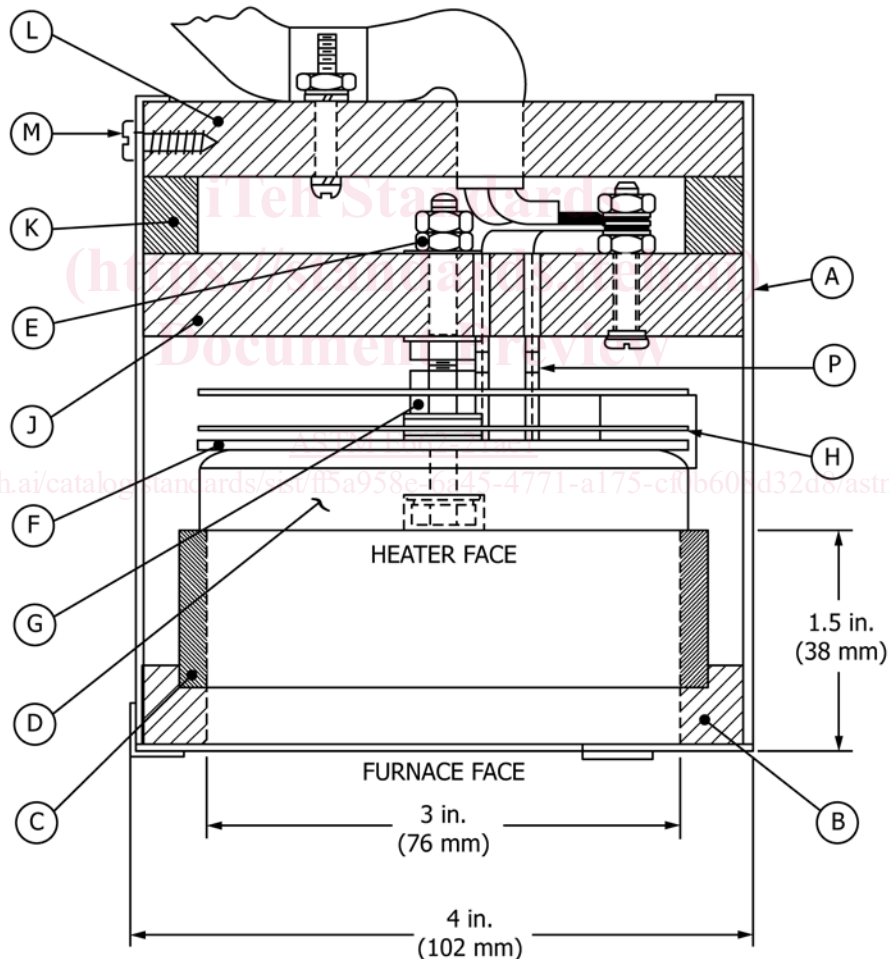

- | | |
|----------------------------------|----------------------------------|
| A—Stainless steel tube | G—Stainless steel spacers |
| B—Front insulating ring | H—Stainless steel reflectors (3) |
| C—Ceramic tube | J—Center insulating disk |
| D—Heater/plate 525 W | K—Insulating spacer ring |
| E—Stainless steel mounting screw | L—Rear insulating disk |
| F—Insulating gasket | M—Sheet metal screw (2) |
| | P—Heater leads/porcelain beads |

FIG. 2 Furnace Section

electric furnace with a 3-in. (76.2 mm) diameter opening shall be used to provide a constant irradiance on the specimen surface. The furnace shall be located along the centerline equidistant between the front and back of the chamber, with the opening facing toward and about 12 in. (305 mm) from the right wall. The centerline of the furnace shall be about 7¾ in. (195 mm) above the chamber floor. The furnace control system shall maintain the required irradiance level, under steady-state conditions with the chamber door closed, of 2.20 ± 0.04 Btu/ft²·s (2.50 ± 0.05 W/cm²) for 20 min.

7.1.2.1 The control system shall consist of one of the following:

(1) An autotransformer and a voltmeter for monitoring the electrical input. Where line voltage fluctuations exceed ± 2.5 V, a constant voltage transformer is required to maintain the prescribed irradiance level.

(2) An electronic temperature controller capable of maintaining furnace temperature ± 5 °F (3 °C). If this option is used, a thermocouple for monitoring the furnace temperature shall be required, and the furnace temperature shall be displayed on the controller or software.

7.1.3 *Specimen Holder*—Specimen holders shall conform in shape and dimension to that shown in Fig. 3 and be fabricated to expose a 2¼ by 2¼-in. (65.1 by 65.1 mm) specimen area.

Also shown in Fig. 3 are the spring and rods for retaining the specimen within the holders.

7.1.4 *Framework for Support of Furnace and Specimen Holder*—The furnace and specimen supporting framework shall be constructed essentially in accordance with Fig. 4.

7.1.5 *Photometric System*—The photometric system shall consist of a light source and photodetector, oriented vertically to reduce measurement variations resulting from stratification of the smoke generated by materials under test. The system shall be as shown in Figs. 5 and 6 and include the following:

7.1.5.1 The light source shall be a 6.5 V incandescent lamp operated at 4 V in a circuit powered by a constant-voltage transformer. The light source shall be mounted in a sealed and light-tight box. This box shall contain the necessary optics to provide a collimated light beam passing vertically through the chamber.

NOTE 2—Operating the light source at 4 V is intended to provide a brightness temperature of 2200 ± 100 K.

7.1.5.2 The photodetector shall be a photomultiplier tube, with an S-4 spectral sensitivity response and a dark current less than 10^{-9} A. A set of nine gelatin compensating filters varying from 0.1 to 0.9 neutral density are mounted one or more as

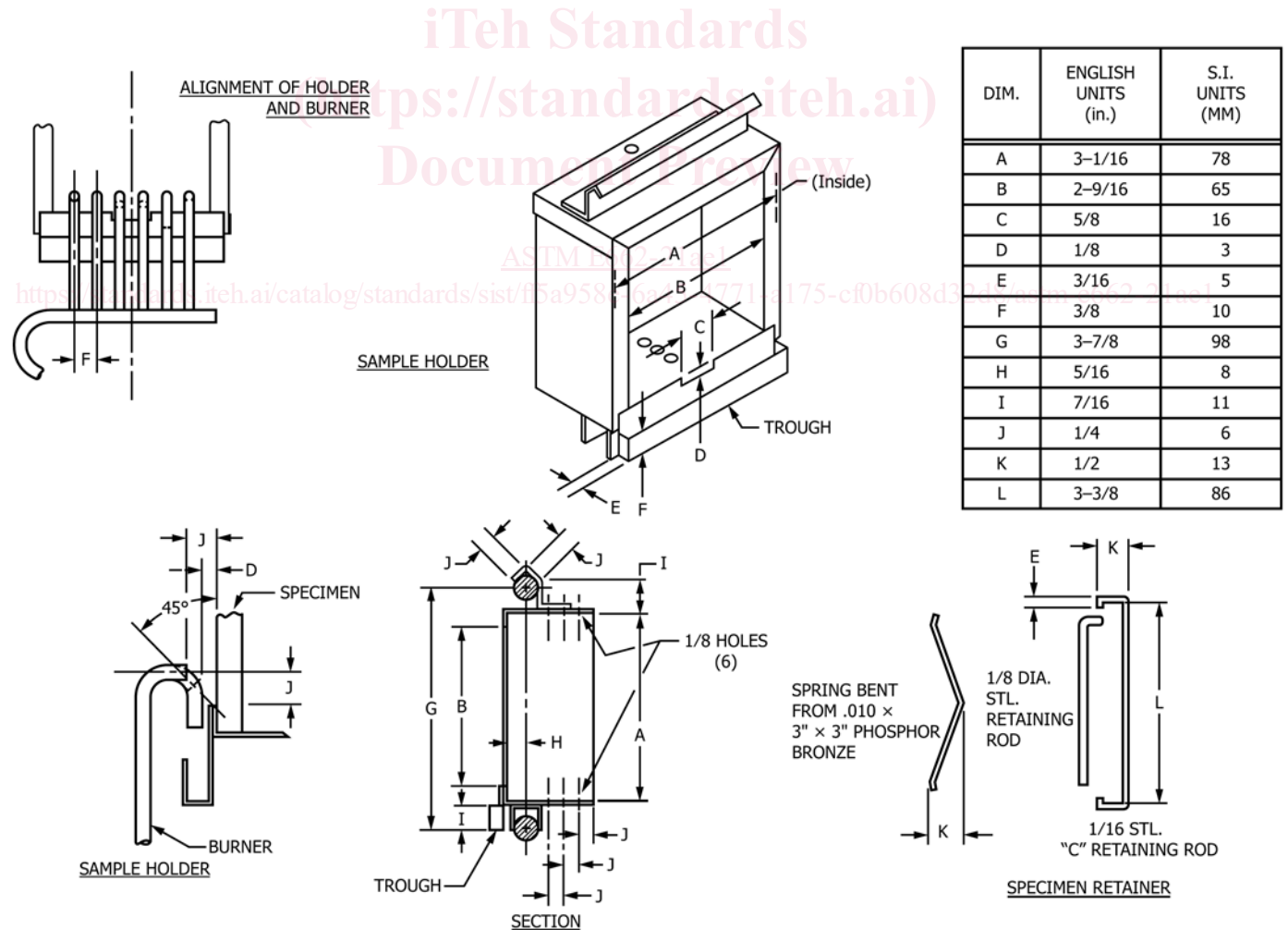

FIG. 3 Details of Specimen Holder and Pilot Burner

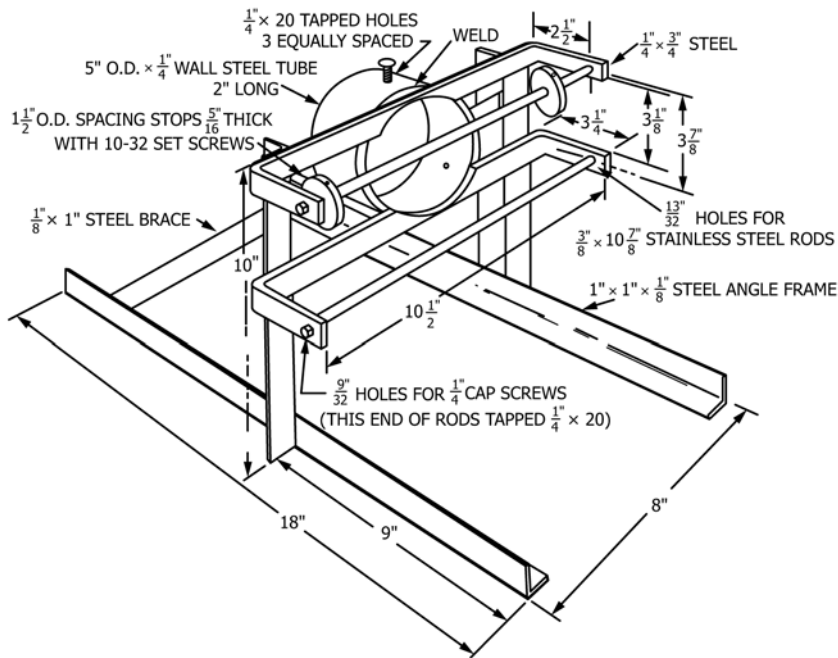

FIG. 4 Furnace Support

required in the optical measuring system to correct for differences in the luminous sensitivity of the photomultiplier tube. These filters also provide correction for light source or photomultiplier aging and reduction in light transmission, through discolored or abraded optical windows. An additional criterion for selection of photomultiplier tubes requires a minimum sensitivity equivalent to that required to give a full scale reading with only the No. 5 compensating filter in the light path. A light-tight box located directly opposite the light source shall be provided to mount the photodetector housing and the associated optics. A glass window shall be used to isolate the photodetector and its optics from the chamber atmosphere.

7.1.5.3 In addition to the above compensating filter, a neutral density range extender filter permitting the system to measure to Optical Density 6 is incorporated in the commercial version of the smoke density chamber. The accuracy of read-outs in the range above D_s 528 is affected by the excessive light scattering present in such heavy smoke concentration. Where D_s values over 500 are measured, it is necessary to provide a chamber window cover to prevent room light from being scattered into the photomultiplier, thereby providing an incorrect higher transmission value.

7.1.6 Radiometer—The radiometer for standardizing the output of the radiant heat furnace shall be of the circular foil type, the operation of which was described by Gardon.⁷ The construction of the radiometer shall be as shown in Fig. 7. It shall have a stainless steel reflective heat shield with a 1½-in. (38.1 mm) aperture on the front and a finned cooler supplied with compressed air mounted on the rear to maintain a constant body temperature of $200 \pm 5^\circ\text{F}$ ($93 \pm 3^\circ\text{C}$).

⁷ Gardon R., "An Instrument for the Direct Measurement of Intense Thermal Radiation," *Review of Scientific Instruments*, Vol 24, 1953, pp. 366–370.

7.1.6.1 As an option to the air-cooled radiometer, a water-cooled heat flux meter is suitable for use in measuring the heat flux. The heat flux meter shall consist of a Schmidt-Boelter (thermopile) sensor approximately 1.0 in. (25.4 mm) in diameter mounted in a specimen holder. The specimen holder shall include the millboard described in 8.3.4.2, with a hole in the center to accommodate the meter. The meter shall be mounted such that the sensing surface is flush with the millboard. The meter shall have an operating range of 0-4.4 Btu/s-ft² (0-5.0 W/cm²) and an accuracy of within $\pm 3\%$.

7.1.7 Thermocouple—A thermocouple shall be fixed to the center of the inner surface of the wall opposite the door.

7.1.8 Output Instrumentation—The outputs of the radiometer shall be measured using a potentiometer and the results recorded. The photodetector output shall be measured with a potentiometer or other suitable instrument capable of measurement over the range of the apparatus. See Annex A1.

7.1.9 Sensor for Chamber Pressure Measurements—A pressure sensor (for example, a manometer or pressure transducer) with a range up to 6 in. (152 mm) of water (1.5 kPa) shall be provided to monitor chamber pressure and leakage. The pressure measurement point shall be through a gas-sampling port in the chamber.

7.1.10 Chamber Pressure Relief System—A simple water column or relief valve shall be provided to permit control of chamber pressure (see A2.8).

7.1.11 Multiple Flamelet Burner—For a flaming exposure test, a six-tube burner, with construction details as shown in Fig. 3, shall be used. The burner shall be centered in front of and parallel to the specimen holder. The tips of the two horizontal tubes shall be centered $\frac{1}{4} \pm \frac{1}{16}$ in. (6.4 ± 1.5 mm) above the lower opening of the specimen holder and $\frac{1}{4} \pm \frac{1}{32}$ in. (6.4 ± 0.8 mm) away from the face of the specimen surface.

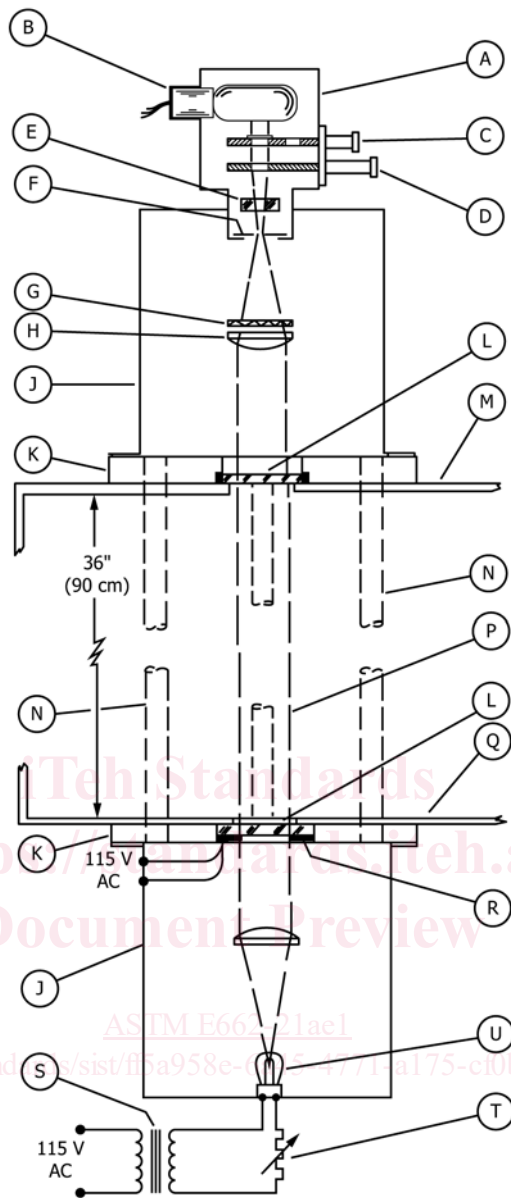

Teh Standards
(http://standards.iteh.ai)
Document Preview

ASTM E662-21ae1

https://standards.iteh.ai/catalog/standards/sist/f5a958e-15-17-14-175-ci0b608d32d8/astm-e662-21ae1

- | | |
|--|---|
| A—Photomultiplier housing | K—Optical system platforms (2) |
| B—Photomultiplier tube and socket | L—Optical windows (2) |
| C—Upper shutter blade, with ND2 filter over one aperture | M—Chamber roof |
| D—Lower shutter blade, with single aperture | N—Alignment rods (3) |
| E—Opal diffuser filter | P—Parallel light beam, 1.5-in. (37.5 mm) diameter |
| F—Aperature disk | Q—Chamber floor |
| G—Neutral density compensating filter (from set of 9) | R—Optical window heater, silicone-fiberglass 50 W/115 V |
| H—Lens, 7 diopter (2) | S—Regulated light source transformer, 115/125 V-6 V |
| J—Optical system housing (2) | T—Adjustable resistor, light source, adjusted for 4 V |
| | U—Light source |

FIG. 5 Photometer Details

Provision shall be made to rotate or move the burner out of position during nonflaming exposures. The fuel shall be propane having a 95 % purity or better. Filtered oil-free air and

propane shall be fed through calibrated flowmeters and needle valves at 500 cm³/min for air and 50 cm³/min for the propane and premixed prior to entry into burner.

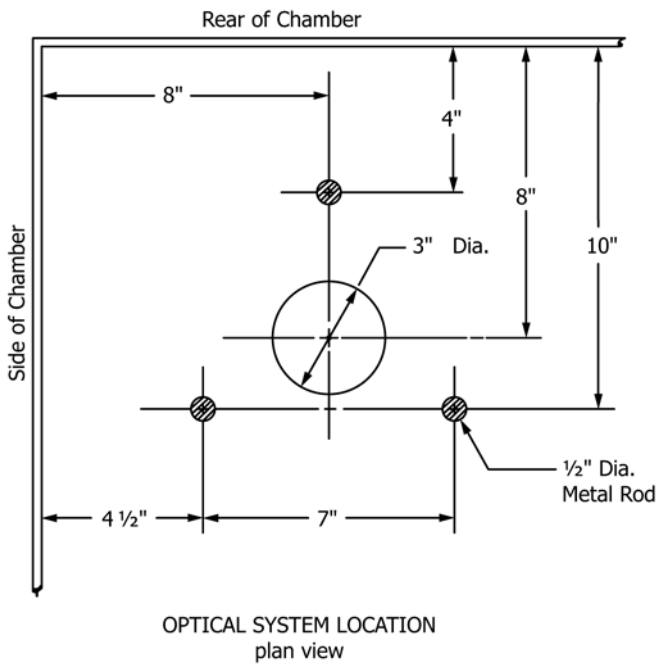

FIG. 6 Photometer Location

rately if required under 8.3.1. The results are valid only for the thickness and form in which it is tested.

8.2 *Specimen Orientation*—If visual inspection of a material indicates a pronounced grain pattern, process-induced orientation or other nonisotropic property, a minimum of three specimens shall be tested for each orientation in each test mode. Exception: Where data are available and to show that orientation of a specimen has no significant effect on test results, the specimen is only required to be tested in one orientation with each test mode (Note 3). When specimens require testing in different orientations, results of tests for each orientation shall be reported separately. Test results from specimens tested under different orientations shall not be used to obtain average values.

NOTE 3—It has been shown the orientation of carpet test specimens in terms of length and width (parallel and perpendicular to manufactured direction) has no statistically significant effect on the specific optical density obtained using this test method (1).⁸

8.3 *Specimen Assembly and Mounting:*

8.3.1 *General*—The specimen shall be representative of the materials or composite and shall be prepared in accordance with recommended application procedures. Flat sections of the same thickness and composition are to be tested rather than curved, molded, or specialty parts. Substrate or core materials for the test specimens shall be the same as those for the intended application. If a material or assembly has the potential to be exposed to a fire on either side, both sides shall be tested. If an adhesive is intended for field application of a finish material or substrate, the prescribed type of adhesive and the spreading rate recommended for field application of the assembly of test specimen shall be used and the details shall be reported.

8.3.2 *Finish Materials*—Finish materials, including sheet laminates, tiles, fabrics, and others secured to a substrate material with adhesive, and composite materials not attached to a substrate, have the potential to be subject to delamination, cracking, peeling, or other separations affecting their smoke generation. To evaluate these effects, it is often necessary to perform supplementary tests on a scored (split) exposed surface, or on interior layers or surfaces. When supplementary tests are conducted for this purpose, the manner of performing such supplementary tests, and the test results, shall be included in the report, together with the test results from the conventional tests.

8.3.2.1 *Finish Materials without Substrate or Core*—For comparative tests of finish materials without a normal substrate or core, and for screening purposes only, the following procedures shall be employed:

8.3.2.2 Rigid or semirigid sheet materials shall be tested by the standard procedure regardless of thickness.

8.3.2.3 In the absence of a specified assembly system, veneers that are not rigid or semi-rigid sheet materials, intended for application to combustible substrate materials, shall be applied to the smooth face of 1/4-in. (6.4 mm) nominal

⁸ The boldface numbers in parentheses refer to the list of references at the end of this standard.

7.1.11.1 It is possible that sample drippings or residue will cause constrictions (or even completely seal) the small openings in the individual burner tiptlets unless the test residues are immediately removed while still warm and viscous. One way to correct or prevent this situation, is for the user to prepare a set of six tempered spring steel wires each approximately 3 1/2 in. (89 mm) long fabricated from 30-gauge (0.014 in.) wire, with one end crimped or brazed to a knob to facilitate handling and to prevent possible loss of the wire by complete insertion. When a burner tiptlet becomes clogged as indicated by flame extinguishment and inability to relight or by a distorted flame shape, thus invalidating the test, insert one of the wires and work it through several times to clear the obstruction. Immediately upon removal of the burner from the chamber while still warm, insert all six wires in a like manner but leave them in place until the next time the burner is used. Where residues and clogging persist, prepare a suitable solvent bath so as to immerse the complete burner and use the wires to loosen any hardened residue. Because of the construction, it is impossible to service the individual burner tiptlets from the opposite direction, but because of ratio of diameters any obstruction pushed through the small diameter tiptlets is likely to readily drop through the large diameter body tubing. Since most of these solvents are hazardous, take proper precautions for handling and protection of personnel. If flammable solvents are used, take care to ensure that “hot” burners are not immersed until cooled to room temperature.

8. Test Specimens

8.1 *Size*—The test specimens shall be 3 by 3, +0, -0.03 in. (76.2 by 76.2, +0, -0.8 mm) by the intended installation thickness up to and including 1 in. (25.4 mm). Materials greater than 1 in. (25.4 mm) thick shall be sliced to 1-in. (25.4 mm) thickness, and each original (uncut) surface tested sepa-

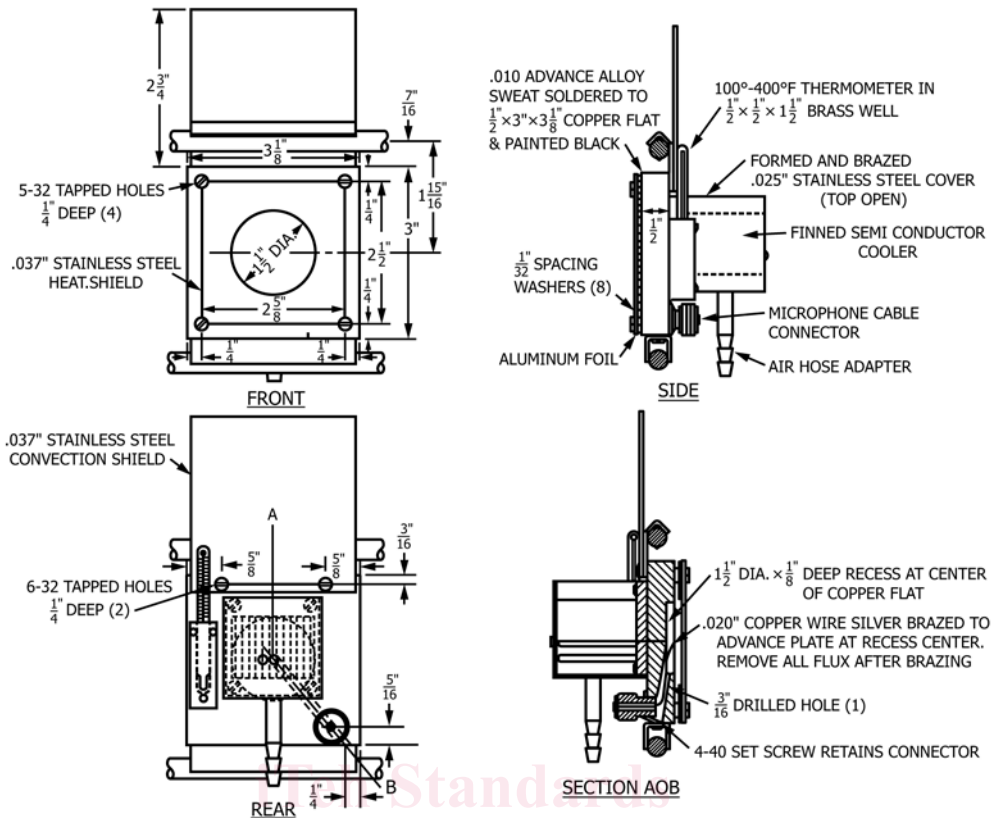

FIG. 7 Radiometer Details

tempered hardboard, complying with ANSI/AHA A135.4 “Basic Hardboard” using recommended application techniques and coverage rates. Supplementary tests shall also be conducted on the hardboard alone, and these values shall be recorded as supplemental to the measured values for the composite specimen. Both sets of values shall be reported.

NOTE 4—Tempered hardboard sheets conforming to ANSI/AHA A135.4 are marked with a 0.5 in. (12.7 mm) wide single red stripe placed on the thickness side approximately 3 in. (76 mm) from each corner. Service tempered hardboard sheets are marked with two red stripes.

8.3.2.4 Paints, adhesives, or similar finish materials shall be applied to the smooth face of 1/4-in. (6.4 mm) thick uncoated fiber cement board, nominally 90 ± 10 lb/ft³ (1440 ± 160 kg/m³) in density, complying with Specification C1288 or C1186, Grade II, using recommended application techniques and coverage rates.

8.3.2.5 *Fabrics and Thin Films*—If fabrics or thin flexible films tend to shrink, to bunch, to blister, or to pull out from under the specimen holder during the test, the three test specimens shall be stapled with its aluminum foil wrapper to the inorganic insulation millboard backing. Five standard size wire staples, approximately 1/2 by 1/4 by 0.02 in. (12.7 by 6.3 by 0.5 mm), shall be positioned horizontally at the center, and at the center of the four quadrants.

8.3.3 *Electrical and Optical Fiber Cables*—For test specimens of electrical or optical fiber cables up to 1 in. (25.4 mm) in diameter, cut the cables to 3 + 0, -0.03 in. (76.2 + 0 - 0.8 mm) lengths and insert enough pieces in the specimen holder to fill it, arranged vertically. Wrap a sheet of 1/2-in. (12.7 mm)

thick inorganic insulation millboard with aluminum foil and place it behind the wires as a backing board before inserting the spring and retaining rod.

8.3.4 *Specimen Mounting:*

8.3.4.1 All specimens shall be covered across the back, along the edges, and over the front surface periphery with a single sheet of aluminum foil (0.001 ± 0.0005 in. or approximately 0.04 mm) with the dull side in contact with the specimen. Care shall be taken not to puncture the foil or introduce unnecessary wrinkles during the wrapping operation. Fold in such a way so as to minimize losses of melted material at the bottom of the holder. Excess foil along the front edges shall be trimmed off after mounting. A flap of foil shall be cut and bent forward at the spout to permit flow from melting specimens.

8.3.4.2 All specimens shall be backed with a sheet of 1/2-in. (12.7 mm) thick inorganic insulation millboard. The specimen and its backing shall be secured with the spring and retaining rod. A modified C-shape retaining rod or similar device shall be used with specimens from 5/8 to 1 in. (16 to 25 mm) thick. Do not deform compressible specimens below their normal thickness.

9. **Conditioning**

9.1 Pre-dry specimens for 24 h at 140 ± 5°F (60 ± 3°C) and then condition to equilibrium (constant weight) at an ambient temperature of 73 ± 5°F (23 ± 3°C) and a relative humidity of 50 ± 5 % (see 6.7).

9.2 While in the conditioning chamber, specimens shall be supported in racks so that air has access to all surfaces. Forced-air movement in the conditioning chamber will assist in accelerating the conditioning process.

10. Number of Test Specimens

10.1 Conduct three tests under flaming exposure and three tests under nonflaming exposure on each material (total of six specimens) in accordance with the conditions described herein.

10.1.1 When any result in any set of three replicates is such that it exceeds the minimum result by 50 %, test an additional set of three replicates and report the average of all six results.

10.1.2 Where one or more of the three replicate tests demonstrate an unusual behavior such as detailed in 6.1, test three additional replicates. Average only the data from the successful tests.

10.2 Prior to use in a test, record the weight of each sample. Comparison of the weights with the individual optical density results has the potential to assist in assessing the reasons for the variability in measurements.

11. Procedure

11.1 Conduct all tests in a room or enclosed space having an ambient temperature of $73 \pm 5^\circ\text{F}$ ($23 \pm 3^\circ\text{C}$) at the time of the test. After conditioning, (see 9.1), specimens shall be moved directly to the room or enclosed space where the smoke density chamber is located. Specimens shall not be exposed to an environment with an uncontrolled relative humidity for more than 15 min prior to testing. Take precautions to provide a means for removing potentially hazardous gases from the area of operation.

11.1.1 Caution is urged during use of apparatus to prevent explosion of pyrolyzates, particularly under nonflaming conditions. Good laboratory procedure is urged also to prevent exposure of the operator to smoke, particularly during removal of the sample from the chamber or in clean-up.

11.2 Measure the air-tightness of the test chamber at least once per test day (with the door, vents and spare gas sampling pipes closed) by introducing compressed air into the test chamber. Air shall be introduced through one of the gas sampling pipes or through the cooling air supply to the radiometer until the pressure is between 3 and 3.5 in. of water gauge (0.76 – 0.87 kPa) and then shutting the air supply off. The chamber shall be considered airtight if the pressure after 5 min is greater than 2 in. of water (0.5 kPa).

11.2.1 Testing shall not be conducted until the chamber passes the air-tightness check in accordance with 11.2.

11.2.2 The air-tightness check shall be repeated in between tests if there is any reason to believe the integrity of any of the seals has been compromised.

NOTE 5—An airtight test chamber helps to ensure accurate results. Leaks in the chamber allow smoke to escape during the test, leading to smoke density results that are lower than those obtained with an airtight chamber.

11.3 Clean the chamber walls whenever periodic visual inspection indicates the need.⁹ Clean the exposed surfaces of the glass windows separating the photodetector and light source housing from the interior of the chamber, before each test (ethyl alcohol is generally effective). Charred residues on the specimen holder and horizontal rods shall be removed between tests to avoid contamination.

11.4 During the warm-up period all electric systems (furnace, light source, photometer readout, etc.) shall be on, the exhaust vent and chamber door closed, and the inlet vent open. When the temperature on the center surface of the back wall reaches a steady-state value in the range of $95 \pm 4^\circ\text{F}$ ($35 \pm 2^\circ\text{C}$) the chamber is ready for furnace calibrating or testing. To increase chamber wall surface temperature to the stated level it is permissible for an auxiliary heater to be used but it shall be removed prior to performing tests; conversely to decrease this temperature, the exhaust blower is a useful tool to introduce cooler air from the laboratory. Standardize the furnace output irradiance at periodic intervals according to test experience (normally twice per test day).

11.5 A “blank” specimen holder, with the inorganic insulation millboard backing exposed shall always be directly in front of the furnace except when displaced to the side by (1) the specimen holder during a test or (2) the radiometer during calibration. It shall be returned immediately to this position when testing or calibration is completed to prevent excessive heating of the adjacent wall surface.

11.6 Perform a furnace calibration in accordance with 11.6.1 if using the radiometer, or 11.6.2 if using a heat flux meter.

11.6.1 Place the radiometer on the horizontal rods of the furnace support framework and accurately position in front of the furnace opening, by sliding and displacing the “blank” specimen holder against the pre-positioned stop. With the chamber door closed and inlet vent opened, adjust the compressed air supply to the radiometer cooler to maintain its body temperature at $200 \pm 5^\circ\text{F}$ ($93^\circ \pm 3^\circ\text{C}$). Adjust the autotransformer or temperature controller setting so as to obtain the calibrated millivolt output of the radiometer corresponding to a steady-state irradiance of 2.2 ± 0.04 Btu/s-ft² (2.5 ± 0.05 W/cm²) averaged over the central 1.5-in. (38.1 mm) diameter area. Use the recorder or meter described in 7.1.8 to monitor the radiometer output. After the prescribed irradiance level has reached steady-state, remove the radiometer from the chamber and replace with the “blank” specimen holder.

11.6.2 Place the heat flux meter on the horizontal rods of the furnace support framework and accurately position in front of the furnace opening, by sliding and displacing the “blank” specimen holder against the prepositioned stop. With the chamber door open and inlet vent opened, turn on the cooling water supply. Adjust the autotransformer or temperature controller setting so as to obtain the calibrated millivolt output of the heat flux meter corresponding to a steady-state irradiance of 2.2 ± 0.04 Btu/s-ft² (2.5 ± 0.05 W/cm²) as measured by the

⁹ An ammoniated spray detergent and soft scouring pads have been found effective.

heat flux meter. Use the recorder or meter described in 7.1.8 to monitor the heat flux meter output. After the prescribed irradiance level has reached steady-state, remove the heat flux meter from the chamber and replace with the “blank” specimen holder.

11.7 After the system has reached steady-state conditions, adjust the zero of the meter or recorder, or both. Adjust the amplifier sensitivity to obtain a full-scale reading of the photodetector (100 % transmittance) on the recorder or readout meter. Determine the “dark current” (0 % transmittance) on the maximum sensitivity range of the readout meter by blocking the light. Adjust the “dark current” reading to zero.

11.8 For nonflaming exposures, remove the multiple flamelet burner. For flaming exposures, position the burner across the lower edge of the specimen as described in 7.1.11. Check the burner distances relative to the “blank” specimen before fuel adjustment and ignition.

11.9 Before positioning the test specimen, flush the chamber with the door and exhaust and inlet vents open for about 2 min, and verify the starting temperature of the chamber, using the procedure described in 11.4.

11.10 Close the exhaust vent and blower. Place the loaded specimen holder on the bar support and push it into position in front of the furnace (with burner in position for flaming exposure) by displacing the “blank” holder. Quickly close the chamber door and simultaneously start the timer or recorder chart drive, or both. Close the inlet vent completely only when the photometer indicates the presence of smoke.

11.11 Record the light transmittance and the corresponding time either as a continuous plot with a multirange recorder or at time intervals no greater than 30 s with a multirange meter readout. Make and note the necessary full-scale range changes in decade steps.

11.11.1 The photometer used with this instrument shall have an accuracy of $\pm 3\%$ or better of the maximum reading on any range. As such, the percentage error of a given reading becomes progressively worse at the lower portion of the scale. Avoid light transmittance on scale readings less than 10 by making the appropriate decade range change.

11.11.2 Some chambers are equipped with a switch that not only incorporates ranges of 100, 10, 1, and 0.1 but also ranges of 30, 3, and 0.3. With such an instrument the greatest accuracy would be achieved in light transmittance readings by making a range change in these intermediate ranges when the light transmittance reading reaches 30 on the 0-to-100 meter scale or 10 on the 0-to-33 scale.

11.12 Observe the increase in chamber pressure with the manometer described in 7.1.9. Use regulator (see A2.8) to maintain the pressure in the range of 4 ± 2 in. (100 ± 50 mm) of water during most of the test. If negative pressure develops after very intense specimen flaming, open the inlet vent slightly to equalize the pressure. As a result of pressure rise, adjust the fuel and air valves during the flaming test to maintain constant flow rate.

11.13 Record any observations pertinent to the burning and smoke generating properties of the material under test, in accordance with 13.1.6 and 13.1.7.

11.14 Continue the test for a period of 3 min after a minimum light transmittance value is reached or after an exposure of 20 min, whichever occurs first.

11.14.1 Optionally, the test shall be permitted to be conducted for periods in excess of 20 min at the request of the test sponsor.

11.15 If transmittance falls below 0.01 %, the chamber window shall be covered with an opaque screen to avoid possible light-scattering effects from room light. Also any supplementary optical filter in the photometer system shall be removed or displaced in order to extend the measuring range. If the potential exists for extraneous light to reflect into the photometer during removal of the filter, turn the high voltage off or adjust the scale to minimize sensitivity. Replace the filter before exhausting smoke from the chamber.

11.16 Extinguish the burner on flaming exposures and start exhausting the chamber within 1 min after terminating the test (see 11.14 and Note 6). Displace the specimen from the front of the furnace by pushing the “blank” specimen holder with the positioning rod. Continue to exhaust with the inlet vent open until maximum transmittance is reached. Record this transmittance value as the T_c , “clear beam” reading.

NOTE 6—In some cases the transmittance will increase somewhat and subsequently decrease to the ultimate minimum transmittance.

12. Calculation

12.1 Calculate specific optical density, D_s , at any given time as follows:

$$D_s = G [\log_{10} (100/T) + F]$$

where:

$$G_{air} = V/AL,$$

V = volume of the closed chamber, ft³ (or m³),

A = exposed area of the specimen, ft² (or m²),

L = length of the light path through the smoke, ft (or m),

T = percent light transmittance as read from the light-sensing instrument, and

F = depends on the following:

(1) If the movable *filter* (see 7.1.5.3) is *in the light path* at the time that T is being measured, $F = 0$, and T is the actual percent transmittance.

(2) If the *filter* has been *moved out of the light path* (see 7.1.5.3 and 11.15) at the time that T is being measured, $F =$ the known optical density of the filter (see A1.1.4), and T is an apparent percent transmittance.

(3) If the optical system is *not equipped* with a *movable filter* in accordance with 7.1.5.3, $F = 0$, and T is the actual percent transmittance.

12.1.1 For an instrument constructed in accordance with this standard, corrections for the volume of the furnace assembly and the volume included in the door recess are generally less than 1 %. As such, $G = 132$.

12.1.2 A table for D_s versus actual percent light transmittance is given in Appendix X2. The D_s values above 528 are based on an assumed optical density of 2.00 for the movable filter.