



Designation: E185 – 21

Standard Practice for Design of Surveillance Programs for Light-Water Moderated Nuclear Power Reactor Vessels¹

This standard is issued under the fixed designation E185; the number immediately following the designation indicates the year of original adoption or, in the case of revision, the year of last revision. A number in parentheses indicates the year of last reappraisal. A superscript epsilon (ϵ) indicates an editorial change since the last revision or reappraisal.

1. Scope

1.1 This practice covers procedures for designing a surveillance program for monitoring the radiation-induced changes in the mechanical properties of ferritic materials in light-water moderated nuclear power reactor vessels. New advanced light-water small modular reactor designs with a nominal design output of 300 MWe or less have not been specifically considered in this practice. This practice includes the minimum requirements for the design of a surveillance program, selection of vessel material to be included, and the initial schedule for evaluation of materials.

1.2 This practice was developed for all light-water moderated nuclear power reactor vessels for which the predicted maximum fast neutron fluence ($E > 1$ MeV) exceeds 1×10^{21} neutrons/m² (1×10^{17} n/cm²) at the inside surface of the ferritic steel reactor vessel.

1.3 This practice does not provide specific procedures for monitoring the radiation induced changes in properties beyond the design life. Practice E2215 addresses changes to the withdrawal schedule during and beyond the design life.

1.4 The values stated in SI units are to be regarded as the standard. The values given in parentheses are for information only.

NOTE 1—The increased complexity of the requirements for a light-water moderated nuclear power reactor vessel surveillance program has necessitated the separation of the requirements into three related standards. Practice E185 describes the minimum requirements for design of a surveillance program. Practice E2215 describes the procedures for testing and evaluation of surveillance capsules removed from a reactor vessel. Guide E636 provides guidance for conducting additional mechanical tests. A summary of the many major revisions to Practice E185 since its original issuance is contained in Appendix X2.

NOTE 2—This practice applies only to the planning and design of surveillance programs for reactor vessels designed and built after the effective date of this practice. Previous versions of Practice E185 apply to earlier reactor vessels. See Appendix X2.

¹ This practice is under the jurisdiction of ASTM Committee E10 on Nuclear Technology and Applications and is the direct responsibility of Subcommittee E10.02 on Behavior and Use of Nuclear Structural Materials.

Current edition approved Sept. 1, 2021. Published October 2021. Originally approved in 1961 as E185 – 61 T. Last previous edition approved in 2016 as E185 – 16. DOI: 10.1520/E0185-21.

1.5 *This international standard was developed in accordance with internationally recognized principles on standardization established in the Decision on Principles for the Development of International Standards, Guides and Recommendations issued by the World Trade Organization Technical Barriers to Trade (TBT) Committee.*

2. Referenced Documents

2.1 *ASTM Standards:*²

- A370 Test Methods and Definitions for Mechanical Testing of Steel Products
- A751 Test Methods and Practices for Chemical Analysis of Steel Products
- E8/E8M Test Methods for Tension Testing of Metallic Materials
- E21 Test Methods for Elevated Temperature Tension Tests of Metallic Materials
- E23 Test Methods for Notched Bar Impact Testing of Metallic Materials
- E170 Terminology Relating to Radiation Measurements and Dosimetry
- E208 Test Method for Conducting Drop-Weight Test to Determine Nil-Ductility Transition Temperature of Ferritic Steels
- E482 Guide for Application of Neutron Transport Methods for Reactor Vessel Surveillance
- E636 Guide for Conducting Supplemental Surveillance Tests for Nuclear Power Reactor Vessels
- E844 Guide for Sensor Set Design and Irradiation for Reactor Surveillance
- E853 Practice for Analysis and Interpretation of Light-Water Reactor Surveillance Neutron Exposure Results
- E900 Guide for Predicting Radiation-Induced Transition Temperature Shift in Reactor Vessel Materials
- E1214 Guide for Use of Melt Wire Temperature Monitors for Reactor Vessel Surveillance
- E1253 Guide for Reconstitution of Irradiated Charpy-Sized Specimens

² For referenced ASTM standards, visit the ASTM website, www.astm.org, or contact ASTM Customer Service at service@astm.org. For *Annual Book of ASTM Standards* volume information, refer to the standard's Document Summary page on the ASTM website.

- E1820** Test Method for Measurement of Fracture Toughness
- E1921** Test Method for Determination of Reference Temperature, T_o , for Ferritic Steels in the Transition Range
- E2215** Practice for Evaluation of Surveillance Capsules from Light-Water Moderated Nuclear Power Reactor Vessels
- E2298** Test Method for Instrumented Impact Testing of Metallic Materials
- E2956** Guide for Monitoring the Neutron Exposure of LWR Reactor Pressure Vessels

2.2 ASME Standards:³

Boiler and Pressure Vessel Code, Section III Subsection NB-2000

Boiler and Pressure Vessel Code, Section XI Nonmandatory Appendix A, Analysis of Flaws, and Nonmandatory Appendix G, Fracture Toughness Criteria for Protection Against Failure

3. Terminology

3.1 Definitions:

3.1.1 *base metal*—as-fabricated plate material or forging material other than a weld or its corresponding heat-affected-zone (HAZ).

3.1.2 *beltline*—the irradiated region of the reactor vessel (shell material including weld seams and plates or forgings) that directly surrounds the effective height of the active core. Note that materials in regions adjacent to the beltline may sustain sufficient neutron damage to warrant consideration in the selection of surveillance materials.

3.1.3 *Charpy transition temperature curve*—a graphic or a curve-fitted presentation, or both, of absorbed energy, lateral expansion, or fracture appearance as functions of test temperature, extending over a range including the lower shelf (5 % or less shear fracture appearance), transition region, and the upper shelf (95 % or greater shear fracture appearance).

3.1.4 *Charpy transition temperature shift*—the difference in the 41 J (30 ft-lbf) index temperatures for the best fit (average) Charpy absorbed energy curve measured before and after irradiation. Similar measures of temperature shift can be defined based on other indices in 3.1.3, but the current industry practice is to use 41 J (30 ft-lbf) and is consistent with Guide E900.

3.1.5 *Charpy upper-shelf energy level*—the average energy value for all Charpy specimen tests (preferably three or more) whose test temperature is at or above the Charpy upper-shelf onset; specimens tested at temperatures greater than 83°C (150°F) above the Charpy upper-shelf onset shall not be included, unless no data are available between the onset temperature and onset +83°C (+150°F).

3.1.6 *Charpy upper-shelf onset*—the temperature at which the fracture appearance of all Charpy specimens tested is at or above 95 % shear.

3.1.7 *heat-affected-zone (HAZ)*—plate material or forging material extending outward from, but not including, the weld fusion line in which the microstructure of the base metal has been altered by the heat of the welding process.

3.1.8 *index temperature*—the temperature corresponding to a predetermined level of absorbed energy, lateral expansion, or fracture appearance obtained from the best-fit (average) Charpy transition curve.

3.1.9 *lead factor*—the ratio of the average neutron fluence ($E > 1$ MeV) of the specimens in a surveillance capsule to the peak neutron fluence ($E > 1$ MeV) of the corresponding material at the ferritic steel reactor pressure vessel inside surface calculated over the same time period.

3.1.9.1 *Discussion*—Changes in the reactor operating parameters or fuel management may cause the lead factor to change.

3.1.10 *limiting materials*—typically the weld and base material with the highest predicted transition temperature using the projected fluence at the end of design life of each material determined by adding the appropriate transition temperature shift to the unirradiated RT_{NDT} . Materials that are projected to most closely approach a regulatory limit at the end of the design life should be considered in selecting the limiting material. Guide E900 describes a method for predicting the Transition Temperature Shift (TTS). Regulators or other sources may describe different methods for predicting TTS. The basis for selecting the limiting weld and base materials shall be documented.

3.1.11 *maximum design fluence (MDF)*—the maximum projected fluence at the inside surface of the ferritic pressure vessel at the end of design life (if clad, MDF is defined at the interface of the cladding to the ferritic steel). Changes during operation will affect the projected fluence and are addressed in Practice E2215.

3.1.12 *reference material*—any steel that has been characterized as to the sensitivity of its tensile, impact and fracture toughness properties to neutron radiation-induced embrittlement.

3.1.13 *reference temperature (RT_{NDT})*—see subarticle NB-2300 of the ASME Boiler and Pressure Vessel Code, Section III, “Nuclear Power Plant Components” for the definition of RT_{NDT} for unirradiated material based on Charpy (Test Method A370) and drop weight tests (Test Method E208). ASME Code Section XI, Appendices A and G provide an alternative definition for the reference temperature (RT_{To}) based on fracture toughness properties (Test Method E1921)

3.1.14 *standby capsule*—a surveillance capsule meeting the recommendations of this practice that is in the reactor vessel irradiation location as defined by Practice E185, but the testing of which is not required by this practice.

3.2 Neutron Exposure Terminology:

3.2.1 Definitions of terms related to neutron dosimetry and exposure are provided in Terminology E170.

4. Significance and Use

4.1 Predictions of neutron radiation effects on pressure vessel steels are considered in the design of light-water

³ Available from the American Society of Mechanical Engineers, Third Park Avenue, New York, NY 10016.

moderated nuclear power reactors. Changes in system operating parameters often are made throughout the service life of the reactor vessel to account for radiation effects. Due to the variability in the behavior of reactor vessel steels, a surveillance program is warranted to monitor changes in the properties of actual vessel materials caused by long-term exposure to the neutron radiation and temperature environment of the reactor vessel. This practice describes the criteria that should be considered in planning and implementing surveillance test programs and points out precautions that should be taken to ensure that: (1) capsule exposures can be related to beltline exposures, (2) materials selected for the surveillance program are samples of those materials most likely to limit the operation of the reactor vessel, and (3) the test specimen types are appropriate for the evaluation of radiation effects on the reactor vessel.

4.2 Guides **E482** and **E853** describe a methodology for estimation of neutron exposure obtained for reactor vessel surveillance programs. Regulators or other sources may describe different methods.

4.3 The design of a surveillance program for a given reactor vessel must consider the existing body of data on similar materials in addition to the specific materials used for that reactor vessel. The amount of such data and the similarity of exposure conditions and material characteristics will determine their applicability for predicting radiation effects.

5. Surveillance Program Design

5.1 This section describes the minimum requirements for the design of a surveillance program for monitoring the radiation-induced changes in the mechanical properties of the ferritic materials that compose the reactor vessel.

5.2 Surveillance Materials:

5.2.1 *Materials Selection*—The surveillance materials shall include, at minimum, the limiting base metal and the limiting weld. If a limiting material is outside the beltline, the limiting beltline base and weld materials shall also be included. If there is no beltline weld, capsules whose target fluence (**Table 1**) is greater than two times the design fluence of the limiting weld are not required to contain weld metal, except that the first capsule must contain the limiting weld material.

NOTE 3—The predicted limiting material may change during operation due to changes that may occur in the transition temperature shift prediction formulation, or other factors. Therefore, it is prudent to include additional potentially limiting materials in the surveillance program as capsule space permits.

5.2.2 *Material Sampling*—A minimum surveillance program shall consist of the material selected in **5.2.1**, taken from the following: (1) base metal from the actual plate(s) or

forging(s) used in the reactor vessel, and (2) weld metal(s) made with the same heat of weld wire and lot of flux and by the same welding procedure as that used for the reactor vessel welds. The base metals used to form the weld shall be from the reactor vessel. If a reactor vessel weld is contained in the beltline, at least one of the base metals used to fabricate the weldment(s) shall be a base metal beltline material included in the surveillance program. Surveillance test specimens shall be removed from full reactor vessel thickness samples.

5.2.3 *Fabrication History*—The fabrication history (austenitizing, quench and tempering, and post-weld heat treatment) of the surveillance materials shall be fully representative of the fabrication history of the reactor vessel materials selected in **5.2.1** and shall be recorded.

5.2.4 *Chemical Analysis Requirements*—The chemical analysis required by the appropriate product specifications for the surveillance materials (base metal and as-deposited weld metal) shall be recorded and shall include copper (Cu), nickel (Ni), manganese (Mn), phosphorus (P), sulfur (S), silicon (Si), carbon (C), and vanadium (V), as well as all other alloying and residual elements commonly analyzed for in low-alloy steel products. The product analysis shall be as described in Test Method **A751** and verified by analyzing samples selected from the base metal and the as-deposited weld metal used for the surveillance program.

5.2.5 *Archive Materials*—Enough material to fill a minimum of three additional capsules per **5.4.2** beyond the minimum number required for the program as defined in **5.8.1** shall be retained with full documentation and identification. This archive should be in the form of full-thickness sections of the original materials (plates or forgings, and welds), because the preferred type and size of test specimens may change in the intervening years. If there is a weld in the beltline, it is recommended that the beltline base metal HAZ material associated with the archive weld material be retained should supplemental data be required. If the designer includes more than one standby capsule in the program, the specimens included in these capsules count toward the archive. However, material sufficient to fill one capsule should be retained as full-thickness sections.

NOTE 4—Experience has shown that it is no longer necessary to include the HAZ material in the surveillance program. However, it is recommended that the HAZ material be included with the archive material.⁴

5.3 Test Specimens

5.3.1 *Type of Specimens*—Charpy V-notch specimens corresponding to the Type A specimen described in Test Methods **A370** and **E23** shall be used. Tension specimens of the type, size, and shape described in Test Methods **A370** and **E8/E8M** are recommended. The gage section of irradiated and unirradiated tension specimens shall be of the same size and shape. Fracture toughness test specimens shall be consistent with the guidelines provided in Test Methods **E1820** and **E1921** and the

TABLE 1 Recommended Withdrawal Schedule

Sequence	Target Fluence	Notes
First	¼ MDF	Testing Required
Second	½ MDF	Testing Required
Third	¾ MDF	Testing Required
Fourth	MDF	Testing Required
Standby	< 2 MDF	Testing Not Required

⁴ Troyer, G., and Erickson, M., “Empirical Analyses of Effects of the Heat Affected Zone and Post Weld Heat Treatment on Irradiation Embrittlement of Reactor Pressure Vessel Steel,” Effects of Radiation on Nuclear Materials, 26th Volume, STP 1572, Mark Kirk and Enrico Lucon, Eds. ASTM International, West Conshohocken, PA, 2014, pp. 155-170.

selected type and size shall be the same for the irradiated and unirradiated condition.

5.3.2 *Specimen Orientation and Location*—Tension, Charpy and fracture toughness specimens representing the base metal (if the included weld was quenched and tempered, this is applicable to weld metal as well) shall be removed from about the quarter-thickness ($1/4$ -T or $3/4$ -T) locations with the mid-length of the specimens at least one thickness (1-T) from any second heat treated surface. The base metal specimens for baseline testing and capsule irradiation should be removed from the same location ($1/4$ -T or $3/4$ -T) for each specimen type and in as close proximity as reasonable to reduce the effect of material variability on radiation-induced mechanical property change measurements. Material from the mid-thickness of the base metal shall not be used for test specimens. Specimens representing weld metal may be removed from any location throughout the thickness with the exception of locations within 13 mm ($1/2$ in.) of the root or surfaces of the welds. Specimens should be centered about the center line of the weld as shown in Fig. 1. Special attention must be given to defining the root of the weld or other material variability (for example base metal dilution) in order to avoid taking weld metal that is different in composition from the surveillance weld metal. The tension and Charpy specimens from base metal shall be oriented so that the major axis of the specimen is parallel to the surface and normal to the principal rolling direction for plates, or normal to the major working direction for forgings as shown in Test Method E23, Annex A5 (T-L orientation). The axis of the notch of the Charpy specimen for base metal and weld metal shall be oriented perpendicular to the surface of the material (expected direction of crack propagation is the principal working direction). The recommended orientation of the weld metal specimens is shown in Fig. 1. Weld metal tension specimens may be oriented in the same direction as the Charpy specimens provided that the reduced section consists entirely of weld metal. The fracture toughness specimens shall have the same orientation as the Charpy specimens.

5.4 Number of Specimens

5.4.1 *Unirradiated Baseline Specimens*—A minimum of 15 Charpy specimens shall be tested to establish full Charpy transition temperature curves for each material per Test Method E23. Instrumented tests are recommended and should be performed in accordance with Test Method E2298. It is recommended that upper-shelf Charpy tests be conducted at multiple temperatures using at least three specimens tested between the upper-shelf onset and onset +83°C (+150°F). At least six tension test specimens shall be tested to establish the unirradiated tensile properties for both the base metal and the weld metal. A minimum of two specimens at room temperature (per Test Method E8/E8M) and two specimens at reactor vessel beltline operating temperature (per Test Method E21) should be tested. The remainder of the tensile specimens may be tested at intermediate temperatures as needed to define the effects of temperature on the tensile properties. It is recommended that a minimum of eight fracture toughness specimens be tested to establish the reference temperature, T_0 , per Test Method E1921 for the limiting material. Optionally, fracture toughness tests can be performed to establish the upper-shelf toughness following Test Method E1820.

5.4.2 *Irradiated Specimens*—The minimum number of test specimens for each irradiation exposure set (capsule) shall be as follows with exception noted in 5.2.1 regarding RPVs with no weld in the beltline:

Material	Charpy	Tension	Fracture Toughness
Each Base Metal	15	3	8 ^A
Each Weld Metal	15	3	8 ^A

^A Only fracture toughness specimens from the limiting material are required; the inclusion of the other material is recommended. It is suggested that a greater quantity of specimens be included in the irradiation capsules whenever possible.

5.5 Irradiation Requirements:

5.5.1 *Encapsulation of Specimens*—Specimens should be maintained in an inert environment within a corrosion-resistant capsule to prevent deterioration of the surface of the specimens during radiation exposure. Care should be exercised in the design of the capsule to ensure that the temperature history of

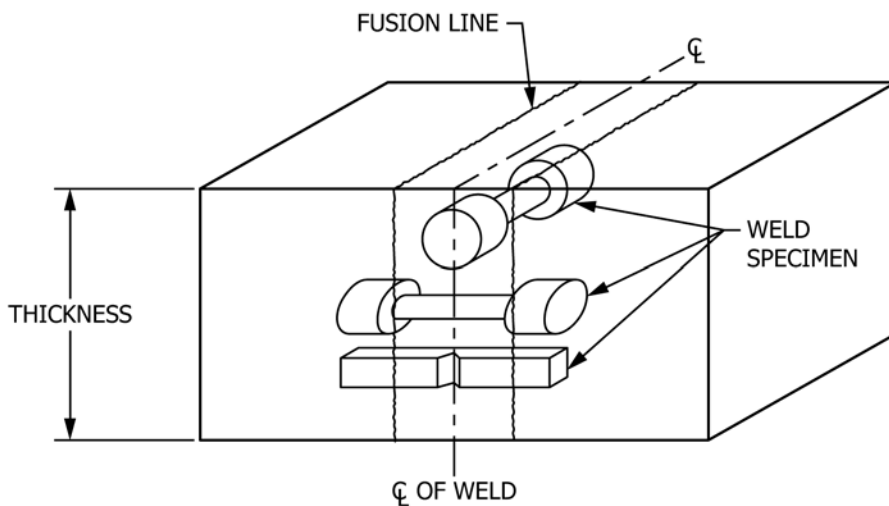

FIG. 1 Location of Test Specimens Within Weld Material

the specimens matches, as closely as possible, the temperature experienced by the reactor vessel. Surveillance capsules shall be designed to prevent mechanical damage to the specimens and monitors during irradiation. The design of the capsule and capsule attachments shall also permit insertion of replacement capsules into the reactor vessel if required at a later time in the lifetime of the vessel. The design of the capsule holder and the means of attachment shall (1) preclude structural material degradation at the attachment, (2) avoid interference with in-service inspection required by ASME Code Section XI, and (3) ensure the functionality of the capsule holder during the service life.

5.5.2 Location of Capsules:

5.5.2.1 *Vessel Capsules (Required)*—Surveillance capsules shall be located within the reactor vessel so that the specimen irradiation history duplicates as closely as possible, within the physical constraints of the system, the neutron spectrum, temperature history, and maximum neutron fluence experienced by the reactor vessel. The beltline material lead factor(s) should be greater than 1.5 and less than five. A lead factor near 1.5 will provide data that will closely duplicate the fluence of the vessel material and will enable monitoring through most of the operating lifetime. Capsules with higher lead factors will provide data earlier in plant life but will limit dosimetry monitoring capability for the later portion of the operating lifetime because it may be necessary to remove all the remaining capsules before the end of the design life due to the high fluence accumulation rate such that twice MDF is not exceeded. This range of lead factors has been selected to minimize the calculational uncertainties in extrapolating the surveillance measurements from the specimens to the reactor vessel wall and to optimize the ability of the program to monitor material property changes throughout the life of the reactor vessel, while keeping potential flux effects to a minimum. During the service life of the reactor vessel the lead factors for individual capsules may change as a result of changes in the reactor operating parameters or fuel management.

5.5.2.2 *Accelerated Irradiation Capsules (Optional)*—The design of some reactor vessel or core internals may not allow the positioning of all surveillance capsules with the recommended lead factors. Additional capsules may be positioned with higher lead factors than those described in 5.5.2.1 for accelerated irradiation. Plants with lead factors greater than five should provide a method of verifying the validity of the accelerated irradiation data. One method by which this verification may be accomplished is the inclusion of a reference material (see 5.6).

5.5.3 Neutron Dosimeters:

5.5.3.1 *Selection of Neutron Dosimeters*—Neutron dosimeters for the surveillance capsules shall be selected according to Guide E844. The group of dosimeters selected shall be capable of providing information about fast neutron fluence, fluence rate, and spectrum; and thermal neutron fluence and fluence rate information; and displacements per atom (dpa) and dpa rate in iron.

5.5.3.2 *Location of Neutron Dosimeters*—Dosimeters shall be located within each surveillance capsule (see 5.5.2.1) and each accelerated capsule (see 5.5.2.2) if used.

5.5.3.3 Dosimetry measurement(s) may be advisable before the withdrawal of the first or between subsequent specimen capsules or after withdrawal of all capsules. If the capsule withdrawal schedule leads to long periods of operation without any dosimetry measurements, separate dosimeter(s) should be used to monitor radiation conditions independent of the surveillance capsules. More information on monitoring the neutron exposure of the reactor pressure vessel may be found in Guide E2956.

NOTE 5—Generally, the preferred location for additional dosimetry is the air gap between the reactor pressure vessel reflective insulation and the biological shield surrounding the reactor. Dosimetry in this location can monitor the neutron exposure of the reactor vessel; both axially and azimuthally. In addition, dosimetry with various azimuthal locations can monitor changes in the core azimuthally, whereas the surveillance capsule dosimeters cannot detect core changes away from the surveillance capsule location. Operationally, dosimetry in this location is more easily removed and replaced than dosimetry located within the vessel.

5.6 Reference Materials:

5.6.1 *Use of Reference Materials*—The use of a reference material is optional. A reference material can provide an indication of possible deviations from the expected surveillance capsule irradiation conditions (for example, temperature and neutron fluence).

5.6.2 *Selection of Reference Materials*—If selected, the irradiation response of the reference material should be well characterized. The dependence of the specified mechanical property change (for example, transition temperature shift or change in yield strength) on irradiation temperature and neutron fluence should be documented to permit a useful evaluation of the irradiation conditions. In addition, reference material uniformity can affect the evaluation of reference material data; therefore, it is recommended that reference material uniformity be considered when a reference material is chosen. The selected reference material should have a measurable property change at surveillance capsule exposure conditions. The usage of reference materials has been documented.⁵ Note that historically there have been some limitations reported in the uniformity of the mechanical properties which have affected the results obtained.

5.7 Temperature Monitoring:

5.7.1 Differences between specimen irradiation temperature and design temperature, occurring as a result of capsule design features, variation in reactor coolant temperature, or both, can affect the extent of radiation induced property changes in the surveillance materials. As a minimum, the temperature of the reactor coolant shall be monitored and recorded. As an option, monitors may be included in the capsule. Since it is not practical to instrument the surveillance capsules, low melting point elements or eutectic alloys can be used as monitors to detect significant variations in exposure temperature. Monitors selected in accordance with Guide E1214 should be used in

⁵ See for example: ASTM DS54, July, 1974; NUREG/CR-4947 on HSST plates; and IAEA-TECDOC-1230, July, 2001, on the JRQ plate.

surveillance programs to provide evidence of the maximum exposure temperature of the specimens.

5.7.2 Instructions for use of temperature monitors are provided in Guide [E1214](#).

5.8 *Number of Surveillance Capsules and Withdrawal Schedule:*

5.8.1 *Number of Capsules*—A sufficient number of surveillance capsules shall be provided to monitor the effects of neutron irradiation on the reactor vessel throughout its design lifetime. At a minimum, the program shall include enough capsules to meet the testing requirements outlined in [5.8.2](#), plus one standby capsule (a total of five capsules). Additional capsules may be desired to monitor the effect of a major core change (which will change the fluence at the end of design life) or annealing of the vessel, or to provide supplemental toughness data for evaluating a flaw in the beltline or for monitoring vessel operation beyond design conditions. The archive material required in [5.2.5](#) is to be used for the additional capsules.

5.8.2 *Withdrawal Schedule*—The capsule withdrawal schedule permits periodic monitoring of long-time irradiation effects. The recommended withdrawal schedule is provided in [Table 1](#).

5.8.2.1 The first step in the implementation of [Table 1](#) is the estimation of the maximum design fluence at the ferritic steel reactor vessel inside surface (identified as MDF).

5.8.2.2 All plants that are required to have a surveillance program per [1.2](#) shall withdraw and test capsules at $\frac{1}{4}$ MDF, $\frac{1}{2}$ MDF, $\frac{3}{4}$ MDF and MDF.

5.8.2.3 Capsules not required by the surveillance withdrawal schedule may be used to provide supplemental data. Supplemental testing may be required to clarify unexpected surveillance results, for operation beyond original design conditions or reactor vessel annealing programs. Supplemental testing may also be based on reconstitution of previously tested specimens following Guide [E1253](#).

5.8.2.4 A minimum of three capsules shall be withdrawn during the first 40 years of reactor operation.

5.8.3 The schedule for capsule withdrawals is approximate and may be adjusted to coincide with a planned refueling outage.

5.8.4 The schedule for capsule withdrawals should be periodically reviewed to adjust for changing lead factors or changing reactor exposure rates resulting from changes in the reactor operating parameters or fuel management. Guidance for reevaluation of the withdrawal schedule is provided in Practice [E2215](#).

6. Capsule Evaluations

6.1 *Baseline Data*—It is recommended that the baseline or unirradiated materials data be obtained during the design of the surveillance program and reported with the program description. Alternatively, the specimens may be placed in secured storage for testing at the time the first surveillance capsule is withdrawn for evaluation.

6.2 *Capsule Evaluation*—Upon removal from the reactor, the surveillance capsule shall be evaluated in accordance with Practice [E2215](#). In addition, supplemental information can be obtained using Guide [E636](#).

7. Report

7.1 The following information shall be provided. Where applicable, both SI units and English units shall be reported.

7.2 *Surveillance Program Description*—Description of the reactor vessel including the following:

7.2.1 Location of the surveillance capsules with respect to the reactor vessel, reactor vessel internals, and the reactor core.

7.2.2 Location in the vessel of the beltline and adjacent plates or forgings and the welds.

7.2.3 Location(s) of the peak vessel fluence.

7.2.4 Lead factor for each capsule.

7.2.5 *Surveillance Material Selection:*

7.2.5.1 Description of all beltline and adjacent materials including chemical analysis, fabrication history, Charpy data, tensile data, drop-weight data and initial RT_{NDT} for the as-fabricated condition.

7.2.5.2 Description of all archive materials including chemical analysis, fabrication history, Charpy data, tensile data, drop-weight data, initial RT_{NDT} , identification markings, and storage location for the as-fabricated condition.

7.3 *Surveillance Material Characterization:*

7.3.1 Description of the surveillance material including fabrication history, material source (heat or lot), and any differences between the surveillance material history and that of the reactor vessel material.

7.3.2 Location and orientation of the test specimens.

7.3.3 *Test Specimen and Environmental Sensor Design:*

7.3.3.1 Description of the test specimens (tension, Charpy, fracture toughness, and any other types of specimens used), neutron dosimeters, and temperature monitors.

7.4 Results of baseline (unirradiated) tests.

APPENDIXES
(Nonmandatory Information)
X1. DESIGN OF INTEGRATED SURVEILLANCE PROGRAMS
X1.1 Background

X1.1.1 In an Integrated Surveillance Program (ISP), surveillance programs conducted for multiple reactor pressure vessels (RPVs) are purposefully coordinated.

X1.1.2 Integration is intended to enhance the measurement of the fleet's irradiation sensitivity by optimizing the usage of available materials over a broader range of exposures than would otherwise be achieved and to maximize the value of otherwise redundant capsules.

X1.1.3 Within an ISP, information acquired from a surveillance capsule extracted from one RPV is combined with information acquired from capsules extracted from other RPVs in the program to improve the condition assessment of all RPVs in the program (the "fleet" of RPVs). In addition, the distribution of a given material amongst capsules experiencing different radiation environments and the scheduling of capsule withdrawals from individual RPVs are coordinated to maximize the possibility of observing trends in mechanical property development versus material and environmental variables. There may be limitations when considering operator license requirements.

NOTE X1.1—When data from more than one RPV-specific surveillance program are combined, then multiple measurements are available at each of a small number of fluences (for example, if each RPV has a similar maximum design fluence, MDF, and each surveillance program follows Practice E185, then measurements will be taken in each RPV at the same four fluences, corresponding to $\frac{1}{4}$ MDF, $\frac{1}{2}$ MDF, $\frac{3}{4}$ MDF and MDF). The multiple measurements may aid in identifying the effects of variables other than fluence (for example, material chemistry) and the extent of measurement uncertainty, but the small number of fluences at which data are typically available limits the ability to extract fluence dependences (that is, embrittlement trend curves). Within an ISP it is not necessary that capsule withdrawals be made from each RPV at the same fluences / MDF fractions. If withdrawals of the same number of capsules are staggered so that information is acquired after a larger number of different fluences (increasing the number of MDF fractions at which data are acquired), then the fluence-dependences of the properties are more readily identified. An ISP also offers the opportunity to expose a given material at more than one lead factor.

X1.2 Scope

X1.2.1 This annex covers procedures for designing an ISP for light-water moderated nuclear power RPVs, including small reactor designs.

X1.2.2 Within an ISP, data are collected in a coordinated fashion from similar reactor designs: minor differences in design details from RPV to RPV are acceptable if they are explicitly characterized in terms of their influence on the neutron spectrum, flux and temperature at the surveillance specimen locations.

X1.2.3 In an ISP, some capsules include RPV materials other than host RPV material in addition to the host RPV material.

X1.2.4 An ISP may be set up for a fleet of two or more RPVs.

X1.2.5 An ISP may be set up from the start of a RPV's surveillance program or by the combination or reorganization, or both, of surveillance programs which have operated for some time. In the latter case, the material measurements made within the initial, RPV-specific surveillance programs contribute to meeting the requirements of the ISP.

X1.3 Terminology

X1.3.1 *Definitions*—Definitions of terms generally applicable to surveillance programs are provided in the Terminology of Practice E185.

X1.3.1.1 *fleet*—the RPVs included within the integrated program.

X1.3.1.2 *parent RPB*—the RPV with which a particular surveillance material is associated.

X1.3.1.3 *host RPV*—the RPV in which the surveillance sample is irradiated.

X1.4 ISP Design

X1.4.1 Within the ISP, the total number of specimens withdrawn representing each parent RPV, and tested, shall be the same as that required by Practice E185 for a plant-specific surveillance program. The capsule contents and requirements shall be as required by Practice E185 except for the specific material, specimen type and withdrawal schedule aspects discussed below.

X1.4.2 Material from a parent RPV should be placed in at least the same number of capsules as in a plant-specific surveillance program. One or more of these capsules may be placed in a different reactor as its host reactor. If so, it will not be necessary for every capsule in the parent reactor to contain all types of limiting materials from the parent reactor.

X1.4.3 Contingency plans shall be made to address potential extended non-operation of a host RPV.

X1.4.4 Sample types and numbers defined in Practice E185 shall be inserted in surveillance capsules for the ISP except that:

X1.4.4.1 While sufficient Charpy samples shall be retained within the overall program to permit continuity with past operating experience and, where necessary, to ensure compliance with the relevant regulatory regime, some Charpy samples may be replaced by additional fracture toughness specimens.

NOTE X1.2—Fracture toughness measurements are of more direct relevance to determinations of the RPV's structural integrity than Charpy measurements.

X1.4.5 Other methods to measure property changes may be additionally included, in some or all capsules, to increase the range of information acquired or to provide additional support