



Designation: E2933 – 21

Standard Specification for Stationary Point Chemical Vapor Detectors (SPCVD) for Homeland Security Applications¹

This standard is issued under the fixed designation E2933; the number immediately following the designation indicates the year of original adoption or, in the case of revision, the year of last revision. A number in parentheses indicates the year of last reapproval. A superscript epsilon (ϵ) indicates an editorial change since the last revision or reapproval.

1. Scope

1.1 General:

1.1.1 This specification presents baseline performance requirements and additional optional capabilities for stationary point chemical vapor detectors (SPCVD) designed for continuous, 24 h a day 7 days a week, monitoring of public, non-industrial facilities. This specification is one of several that describe chemical vapor detectors (for example, handheld and stationary) and chemical detection capabilities including: chemical vapor hazard detection, identification, classification, and quantification. An SPCVD is capable of detecting and alarming when exposed to chemical vapors that pose a risk as defined by the Acute Exposure Guideline Levels for Selected Airborne Chemicals (AEGL). For example, chemical vapors of interest for homeland security applications, see [Appendix X1](#). The SPCVD should not alarm to background chemical vapors and should provide low false positive alarm rates and no false negatives. Procurement agents and end users must identify the specific chemicals of interest and environmental requirements for the given facility.

1.1.1.1 An SPCVD samples air from immediate surroundings and is comprised of one or more detectors using one or more chemical detection technologies. An SPCVD also includes air sampling system(s), power system(s), computer(s), data storage, data network communication interface(s), and an enclosure, see [Fig. 1](#). An SPCVD may be combined with other SPCVDs, other chemical, biological, radiological, nuclear, and explosive (CBRNE) detectors, and other monitoring devices such as video. A remote command center may monitor and control these devices and communicate information to the responsible authorities and responders, as depicted in [Fig. 2](#).

1.1.2 This specification provides the SPCVD baseline requirements, including performance, system, environmental, and documentation requirements. This specification provides SPCVD designers, manufacturers, integrators, procurement

personnel, end users/practitioners, and responsible authorities a common set of parameters to match capabilities and user needs.

1.1.3 This specification is not meant to provide for all uses. Manufacturers, purchasers, and end users will need to determine specific requirements based on the installation location and environment.

1.2 *SPCVD Chemical Detection Capabilities*—Manufacturers document and verify, through testing, the chemical detection capabilities of the SPCVD. Test methods for assessing chemical detection capabilities are available from the Department of Homeland Security and the Department of Defense and are listed in [Appendix X2](#).

1.3 *SPCVD System and Environmental Properties*—Manufacturers document and verify, through testing, the system and environmental properties of the SPCVD. Example test methods for assessing the system and environmental properties are listed in [Appendix X3](#).

1.4 *Units*—The values stated in SI units are to be regarded as standard. Vapor concentrations of the hazardous materials are presented in parts per million (ppm) as used in Acute Exposure Guideline Levels for Selected Airborne Chemicals, Vols 1-9 (see [2.2](#)) and in mg/m^3 .

1.5 *This standard does not purport to address all of the safety concerns, if any, associated with its use. It is the responsibility of the user of this standard to establish appropriate safety, health, and environmental practices and determine the applicability of regulatory limitations prior to use.*

1.6 *This international standard was developed in accordance with internationally recognized principles on standardization established in the Decision on Principles for the Development of International Standards, Guides and Recommendations issued by the World Trade Organization Technical Barriers to Trade (TBT) Committee.*

¹ This specification is under the jurisdiction of ASTM Committee E54 on Homeland Security Applications and is the direct responsibility of Subcommittee E54.01 on CBRNE Detection and Decontamination.

Current edition approved Sept. 1, 2021. Published September 2021. Originally approved in 2013. Last previous edition approved in 2013 as E2933 – 13. DOI: 10.1520/E2933-21.

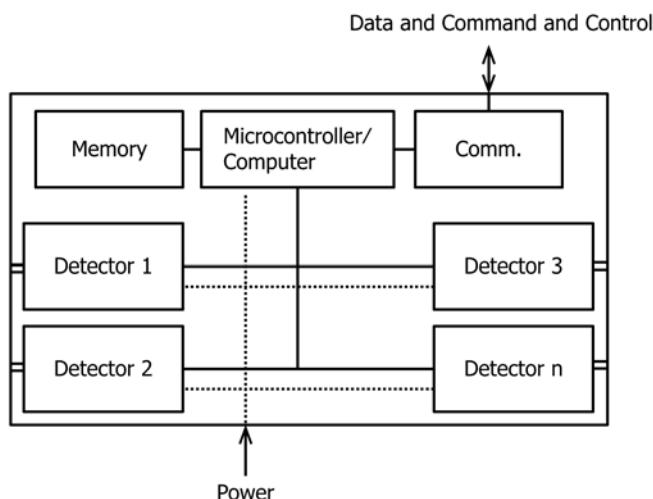

The SPCVD is a unit which samples air from immediate surroundings and is comprised of one or more detectors using one or more chemical detection technologies. An SPCVD also includes air sampling system(s), power system(s), computer(s), data storage, data network communication interface(s), and an enclosure.

FIG. 1 An Example Schematic of a Stationary Point Chemical Vapor Detector (SPCVD)

2. Referenced Documents

2.1 ASTM Standards:²

E2885 Specification for Handheld Point Chemical Vapor Detectors (HPCVD) for Homeland Security Applications

2.2 U.S. Environmental Protection Agency:³ Acute Exposure Guideline Levels for Selected Airborne Chemicals, Vols 1–9.

2.3 U.S. Department of Homeland Security:⁴ Chemical Detection Performance Specifications for Mass Transit and Passenger Rail Systems

National Information Exchange Model (NIEM), <http://www.niem.gov/>.

2.4 National Institute of Standards and Technology (NIST):⁵ Publication 140–2 Security Requirements for Cryptographic Modules

2.5 Code of Federal Regulations:⁶

CFR, Title 40 Protection of the Environment, Part 72.2 Permits Regulation, Definitions.

CFR, Title 10 NRC Regulations, Part 30.20, Gas and Aerosol Detectors Containing Byproduct Material

² For referenced ASTM standards, visit the ASTM website, www.astm.org, or contact ASTM Customer Service at service@astm.org. For *Annual Book of ASTM Standards* volume information, refer to the standard's Document Summary page on the ASTM website.

³ Committee on Acute Exposure Guideline Levels, Committee on Toxicology, Board on Environmental Studies and Toxicology, Division on Earth and Life Studies, National Research Council of the National Academies; 2000-2010, <http://www.epa.gov/oppt/aegl/index.htm>, updated August 2010.

⁴ Available from the Office of Health Affairs, Chemical Defense Program, and the Transportation Security Administration, 245 Murray Lane, NW, Mail Stop 0315, Washington, D.C. 20528, March 2011.

⁵ Available from National Institute of Standards and Technology (NIST), 100 Bureau Dr., Stop 1070, Gaithersburg, MD 20899-1070, <http://www.nist.gov>. May 2001.

⁶ Available from U.S. Government Printing Office Superintendent of Documents, 732 N. Capitol St., NW, Mail Stop: SDE, Washington, DC 20401, <http://www.access.gpo.gov>.

CFR Title 47 Telecommunication, Part 15 Radio Frequency Devices, and Part 18 Industrial, Scientific, and Medical Equipment.

3. Terminology

3.1 Definitions:

3.1.1 30-minute Acute Exposure Guideline Levels for Selected Airborne Chemicals (30-min AEGL value), *n*—represent threshold exposure limits for the general public and are applicable to emergency exposure periods for 30 minutes.

3.1.2 AEGL-1, *n*—airborne concentration (expressed as parts per million (ppm) or mg/m³) of a substance above which it is predicted that the general population, including susceptible individuals, could experience notable discomfort, irritation, or certain asymptomatic nonsensory effects; however, the effects are not disabling and are transient and reversible upon cessation of exposure.

3.1.3 AEGL-2, *n*—airborne concentration (expressed as ppm or mg/m³) of a substance above which it is predicted that the general population, including susceptible individuals, could experience irreversible or other serious, long-lasting adverse health effects or an impaired ability to escape.

3.1.4 AEGL-3, *n*—airborne concentration (expressed as ppm or mg/m³) of a substance above which it is predicted that the general population, including susceptible individuals, could experience life-threatening health effects or death.

3.1.5 alarm, *n*—sound, light, vibration, or data communication signal to the operator(s), or combinations thereof, indicating that the stationary point chemical vapor detector (SPCVD) has detected the presence of a chemical vapor(s) of interest at or above the alarm threshold value.

3.1.6 alarm threshold value, *n*—vapor concentration corresponding to an AEGL value (AEGL-1, AEGL-2, or AEGL-3) that activates an SPCVD alarm.

3.1.7 background chemical vapors, *n*—incidental chemical vapors present in the environment at vapor concentrations lower than the 30-minute AEGL-1 values.

3.1.8 consumables, *n*—SPCVD components that require periodic replacement.

3.1.9 enclosure, *n*—an integral part of the SPCVD that protects the internal SPCVD components from harm including effects from temperature, moisture, dust, mechanical stress, and tampering.

3.1.10 facility, *n*—area, structure, or surroundings, or combinations thereof, to be monitored by the SPCVD (for example, a building, parking lot, transportation station, and airport).

3.1.11 false negative, *n*—the SPCVD fails to alarm in the presence of a chemical of interest when the vapor concentration is at or above the indicated alarm threshold value.

3.1.12 false positive alarm, *n*—the SPCVD indicates the presence of a chemical of interest when none is present or if the chemical is present at vapor concentrations less than 50 % of the indicated alarm threshold value.

3.1.13 identify, *v*—indicate actual chemical detected by the SPCVD.

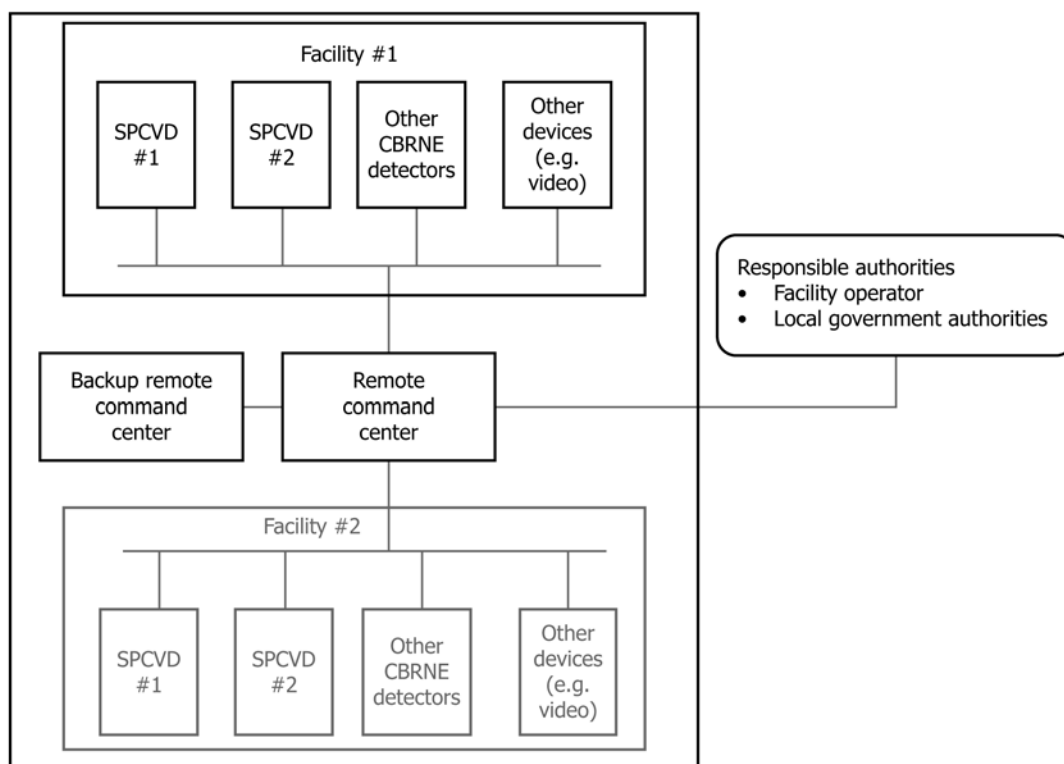

FIG. 2 A Conceptual Representation of a Facility Security System with Stationary Point Chemical Vapor Detectors (SPCVDs) integrated with other Chemical, Biological, Radiological, Nuclear, and Explosive (CBRNE) Detectors, and Other Monitoring Devices such as Video

3.1.14 *indicator, n*—information other than an alarm provided to the operator(s) by the SPCVD.

3.1.15 *laboratory challenge stream, n*—a synthesized chemical vapor mixture used in the laboratory to verify the chemical detection capabilities of an SPCVD.

3.1.16 *local operations, n*—control and monitoring of the SPCVD at or near the physical location of the SPCVD.

3.1.17 *mean time between failures, n*—estimate of the elapsed time between inherent failures of a system during operation, one measure of system reliability.

3.1.18 *probability of detection, n*—under specific conditions, the probability that the SPCVD will activate an alarm when a chemical of interest is present at or above the alarm threshold values.

3.1.19 *remote command center, n*—a location where an operator remotely controls and monitors SPCVD(s), other CBRNE detectors, and other monitoring devices; the remote command center communicates information to the responsible authorities, see Fig. 2.

3.1.20 *remote operations, n*—control and monitoring of the SPCVD from a remote command center.

3.1.21 *response time, n*—time required for the SPCVD to detect and activate an alarm when exposed to a chemical of interest at vapor concentrations at or above the alarm threshold value.

3.1.22 *saturation, n*—a condition in which the detector response no longer increases with increased vapor concentration.

3.1.23 *selectivity, n*—ability of an SPCVD to distinguish one or more chemicals of interest in the presence of background chemical vapors.

3.1.24 *sensitivity, n*—ability to detect one or more chemicals of interest at the alarm threshold values within the specified response time.

3.1.25 *stationary point chemical vapor detector (SPCVD), n*—a unit which samples air from immediate surroundings and is comprised of one or more detectors using one or more chemical detection technologies; an SPCVD also includes air sampling system(s), power system(s), computer(s), data storage, data network communication interface(s), and an enclosure, see Fig. 1; an SPCVD may be integrated into a larger monitoring system, as depicted in Fig. 2.

3.1.26 *vapor, n*—in the context of this specification, vapor refers to either gases or gas phase chemicals where the same substance may also exist in either a liquid or solid state.

4. Chemical Detection Performance Requirements

4.1 The manufacturer shall document the baseline and additional optional capabilities of the SPCVD to detect, identify, and quantify the chemical vapor hazards.

4.2 Detection and Hazard Identification:

4.2.1 The baseline capability of the SPCVD is to detect and alarm to one or more hazardous chemical vapors listed in the Acute Exposure Guideline Levels for Selected Airborne Chemicals. Tables X1.1 and X1.2 in Appendix X1 provide a representative list of chemical vapor hazards.

4.2.2 The SPCVD shall detect the manufacturer-documented chemical vapors without user intervention.

4.2.3 The SPCVD:

4.2.3.1 Shall alarm in the presence of manufacturer-documented chemical vapors at the vapor concentrations given in 4.3 with response times given in 4.4;

4.2.3.2 Shall indicate each 30-min AEGL value that the detected chemical vapor(s) is at or above; and

4.2.3.3 Shall indicate the specific chemical(s) that is detected.

4.3 *Sensitivity*:

4.3.1 For each manufacturer-documented chemical vapor, the manufacturer:

4.3.1.1 Shall declare and document the SPCVD capability to alarm at the 30-min AEGL-2 value;

4.3.1.2 May declare and document the SPCVD capability to alarm at the 30-min AEGL-1 value; and

4.3.1.3 May declare and document the SPCVD capability to alarm at the 30-min AEGL-3 value.

4.3.2 The SPCVD shall:

4.3.2.1 Automatically cease the alarm signal within 2 min after the concentration drops below half of the alarm threshold values; and

4.3.2.2 Include an indicator that is activated in the event of an alarm and remains activated until an operator resets the indicator.

4.3.3 At vapor concentrations greater than the 30-min AEGL-3 values:

4.3.3.1 The SPCVD shall continue to alarm;

4.3.3.2 If a detector is saturated, the SPCVD shall indicate it is saturated; and

4.3.3.3 The SPCVD should be designed to avoid detector saturation at vapor concentrations below twice the AEGL-3 vapor concentration values.

4.3.4 The SPCVD should indicate the vapor concentration of the chemical(s) present in absolute quantities (for example, ppm or mg/m³).

4.4 *Response Time*—The SPCVD shall detect and alarm within times indicated in Table 1 for 30-min AEGL-2 values and may optionally detect and alarm within the times for 30-min AEGL-1 values and 30-min AEGL-3 values.

4.5 *Chemical Detection Climate*—For each of the manufacturer-documented chemical detection capabilities:

4.5.1 The SPCVD shall perform within the temperate climate range or the indoor climate range listed in Table 2;

4.5.2 The SPCVD may perform within the low- or high-temperature climate ranges, or both, listed in Table 2;

4.5.3 The chemical detection capabilities within each climate range shall be demonstrated by tests at the temperatures and relative humidities listed in Table 3;

TABLE 2 SPCVD Chemical Detection Climate Ranges

Climate Ranges	Temperature (°C)	% Relative Humidity	Water Vapor Content (g/m ³)
Low Temperature	-10 to 5	5 to 100	0.1 to 6.8
Temperate	5 to 35	5 to 100	0.3 to 32
High Temperature	35 to 50	5 to 77	2.0 to 32
Indoor	15 to 27	25 to 75	3.2 to 17

TABLE 3 SPCVD Testing Conditions

Climate Ranges	Temperature, °C	% Relative Humidity	Water Vapor Content, g/m ³
	7 ± 2	77 ± 25	6 ± 2
Temperate	33 ± 2	17 ± 6	6 ± 2
	33 ± 2	78 ± 6	29 ± 2
Low Temperature	-5 ± 2	0 + 68	0 + 2
		High Temperature	45 ± 2
Indoor	17 ± 2	21 ± 17	3 ± 2
	25 ± 2	72 ± 18	17 ± 2

4.5.4 The SPCVD shall perform within the range of the manufacturer-documented atmospheric pressures;

4.5.5 The SPCVD should perform in the presence of transient pressure pulses; and

4.5.6 The manufacturer may extend the range of operation.

4.6 *Probability of Detection*—For each of the manufacturer-documented chemical vapors, the SPCVD shall achieve a probability of detection of at least 90 % under any condition within each of the manufacturer-documented climate range(s) as specified by 90 % lower confidence bound (see Table 4). For a detailed explanation, see Specification E2885. The probability of detection shall be verified by:

4.6.1 Testing a single SPCVD, representative of all the SPCVDs with the same model designation, which shall detect and alarm:

4.6.1.1 For 21 of 21 replicate tests; or

4.6.1.2 For 36 of 37 replicate tests.

4.6.2 The replicate tests shall be performed:

4.6.2.1 Using laboratory challenge streams that shall consist of the chemical of interest diluted in zero air (see CFR Title 40, Part 72.2).

4.6.2.2 With the laboratory challenge streams at the temperatures and humidities listed in Table 3.

4.6.3 The vapor concentration of the chemical of interest shall:

4.6.3.1 Be measured by an independent method, and

4.6.3.2 Have a measured value at the documented AEGL value plus the expanded uncertainty of the measured vapor concentration at the 95 % confidence level. Therefore, the vapor concentration of the laboratory challenge stream shall be set above the AEGL value by an amount equal to the expanded measurement uncertainty.

4.7 *False Positive Alarm Characterization*:

4.7.1 The SPCVD shall not alarm when exposed to laboratory challenge streams representing each potential background chemical vapor.

TABLE 1 SPCVD Response Time

30-min AEGL Values	Maximum Response	Requirement
	Time	
AEGL-2	120 s	Required
AEGL-1	15 min	Optional
AEGL-3	30 s	Optional

TABLE 4 Minimum Numbers of Test Required to Obtain a Lower Bound for the Specified Probability of Detection and Alarm with the Specified Confidence Risk

NOTE 1—The first number in each interior cell of the table assumes all tests result in an alarm. The second number in each cell assumes all tests but one result in an alarm. For detailed explanations, see Specification E2885.

		Confidence Level							
		0.60	0.65	0.70	0.75	0.80	0.85	0.90	0.95
Probability of Detection and Alarm	0.60	1/4	2/4	2/5	2/5	3/6	3/7	4/8	5/9
	0.65	2/5	2/5	2/6	3/6	3/7	4/8	5/9	6/11
	0.70	2/6	2/6	3/7	3/8	4/8	5/9	6/11	8/13
	0.75	3/7	3/8	4/9	4/9	5/10	6/12	8/14	10/17
	0.80	4/9	4/10	5/11	6/12	7/13	8/15	10/17	13/21
	0.85	5/12	6/14	7/15	8/17	9/18	11/21	14/24	18/29
	0.90	8/19	9/21	11/23	13/26	15/28	18/32	21/37	28/45
	0.95	17/39	20/43	23/48	27/52	31/58	36/66	44/76	58/92

(<https://standards.iteh.ai>)

Document Preview

4.7.1.1 The specific background chemical vapors of interest are:

- (1) Glycol ethers,
- (2) Exhaust from low-sulfur diesel fuel,
- (3) Commercial glass cleaner, without glycol,
- (4) Solvent mixture of toluene, xylene, methanol, and ethanol, and
- (5) D-Limonene.

4.7.1.2 Each laboratory challenge stream shall:

- (1) Consist of one of the specific background chemical vapors of interest at 1 % of the saturation vapor pressure at 23 °C diluted in zero air;
- (2) Be at a temperature between 20 °C and 25 °C and a relative humidity between 45 % and 55 %; and
- (3) Not contain any chemical on the AEGL list at concentrations greater than the 30-min AEGL-1 vapor concentration value.

4.7.2 To characterize the false positive alarm rate, the manufacturer should test the SPCVD in the field under environmental conditions similar to sites at which the SPCVD might be installed. This test should have a minimum duration of 600 h. The manufacturer shall document:

4.7.2.1 The test conditions including a description of the test location (for example, indoor, outdoor, transportation system) and potential background chemical vapors or sources of background chemical vapors, or both, that could cause a false positive alarm;

4.7.2.2 The number of hours operated in the environment;

4.7.2.3 The range of temperatures, pressures, and relative humidity values; and

4.7.2.4 The indicated chemical, indicated alarm level, number of events, time, and duration of each alarm, if any.

4.7.3 The manufacturer may document any additional capability of the SPCVD to reject common background chemical vapors by documenting the chemical vapors and concentrations used in testing for false positive alarms.

4.8 Sensitivity in the Presence of Background Chemicals:

4.8.1 For each of the manufacturer-documented chemical vapors, the SPCVD shall alarm when exposed to laboratory challenge streams which are mixtures of the chemical vapors of interest with potential background chemical vapors.

4.8.1.1 The specific background chemical vapors of interest are:

- (1) Glycol ethers,
- (2) Exhaust from low-sulfur diesel fuel,
- (3) Commercial glass cleaner, without glycol,
- (4) Solvent mixture of toluene, xylene, methanol, and ethanol, and
- (5) D-Limonene.

4.8.1.2 Each laboratory challenge stream shall:

(1) Consist of the chemical vapor of interest with a measured chemical vapor concentration at the 30-min AEGL-2 value plus the expanded uncertainty of the measured vapor concentration at the 95 % confidence level. Therefore, the vapor concentration of the laboratory challenge stream shall be

set above the AEGL value by an amount equal to the expanded measurement uncertainty.

(2) Consist of one of the specific background chemical vapors of interest at 1 % of the saturation vapor pressure at 23 °C mixed with zero air to provide a challenge stream at ambient pressure; and

(3) Be at a temperature between 20 °C and 25 °C and a relative humidity between 45 % and 55 %.

4.9 Limitations of Testing—The complex nature of chemistry, the environment, and the interaction of chemicals with the environment may impact a manufacturer’s ability to demonstrate, through testing, that an SPCVD meets all of the requirements for all hazardous chemical vapors under all environmental conditions. Testing under extreme cases is not required. For example:

4.9.1 The SPCVD is not required to meet requirement 4.3.2 with persistent chemical vapors (for example, VX). The manufacturer shall note the chemicals for which the SPCVD does not meet the requirement.

4.9.2 Generation of laboratory challenge streams may be difficult at elevated relative humidities (greater than 90 %); therefore, tests at relative humidities greater than 90 % are not required.

4.9.3 Laboratory tests with a large number of mixtures of background chemical vapors and chemicals of interest are informative. This specification requires a minimum number of test mixtures; therefore, it provides only a limited amount of information on how an SPCVD will perform in the field.

4.10 Detection Capabilities for Chemicals Not on the AEGL List—The manufacturer may document chemical detection capabilities for chemicals not on the AEGL list.

4.10.1 The manufacturer shall document the vapor concentrations at which the alarms are triggered.

4.10.2 The manufacturer shall correlate the alarms with published studies on health effects.

4.10.3 The SPCVD shall indicate the specific chemical that is detected; and

4.10.4 The SPCVD should indicate the vapor concentration of the chemical present in absolute quantities (for example, ppm or mg/m³).

5. System Requirements

5.1 System Properties—The SPCVD:

5.1.1 Shall be designed for continuous operation;

5.1.2 Shall meet applicable building codes and electrical codes;

5.1.3 Shall include tamper-proof and vandal-proof features to ensure the physical security of the SPCVD; and

5.1.4 Shall be designed to withstand the environment at the installed location.

5.2 Sample Port(s):

5.2.1 Each sample port shall be equipped with an appropriate air filter.

5.2.2 The SPCVD shall monitor each air filter’s condition and indicate when the filter needs replacement.

5.3 Controls, Alarms, and Indicators—The SPCVD:

5.3.1 Shall display alarms and indicators in English and may display in additional languages;

5.3.2 Shall provide indicators relaying information including power system status, malfunction, and maintenance requirement;

5.3.3 Shall provide an operational status message on a regular basis to the remote command center or the local display;

5.3.4 Shall include an indicator that is activated in the event of an alarm and remains activated until an operator resets the indicator;

5.3.5 May be capable of communicating all controls, alarms, and indicators over a data network with a remote command center; and

5.3.6 May provide local display of or local access to, or both, controls, alarms, and indicators. These features shall only be accessible, audible, and visible to a local operator and not to the public.

5.4 Power:

5.4.1 If there is an interruption in the power, the SPCVD shall perform a controlled, safe shutdown; and

5.4.2 Upon restoration of power, the SPCVD shall return to normal operation with no loss of data.

5.5 Reliability—The SPCVD:

5.5.1 Shall provide a means to verify that the SPCVD is functional;

5.5.2 Shall have a mean time between failures of at least 9000 operating hours;

5.5.3 Should have at least a ten-year operational life; and

5.5.4 Should have at least a three-year operational life for the chemical vapor detector component(s).

5.6 Maintainability—The SPCVD:

5.6.1 Shall be designed for onsite maintenance by an authorized person;

5.6.2 Should require routine maintenance no more often than once per month; and

5.6.3 Should require preventative maintenance no more often than every six months.

5.7 Software—The SPCVD:

5.7.1 Shall be delivered with software installed;

5.7.2 Shall provide for software version control; and

5.7.3 Shall provide configurable access accommodating multiple user levels (for example, maintenance, operator, and administrator).

5.8 Data—The SPCVD:

5.8.1 Shall include a non-volatile internal memory;

5.8.2 Shall store at least the last 168 continuous hours (one week) of data;

5.8.3 Shall periodically send specific data output to the remote command center or local display and include:

5.8.3.1 SPCVD identification;

5.8.3.2 SPCVD status (functioning, non-functioning);

5.8.3.3 Power status;

5.8.3.4 Memory status;

5.8.3.5 Date and time; and

5.8.3.6 Self-test results and diagnostic status.

5.8.4 Shall, in the event of an alarm, send specific data output to the remote command center or local display and include:

- 5.8.4.1 SPCVD identification (including serial number, code, or name);
- 5.8.4.2 Hazardous chemical(s) detected;
- 5.8.4.3 Alarm level(s) (AEGL-1, AEGL-2, or AEGL-3); and
- 5.8.4.4 Vapor concentration; if applicable.

5.9 *Data Communications with the Remote Command Center, if applicable*—The SPCVD:

- 5.9.1 Shall be designed to interface with the system into which it is integrated;
- 5.9.2 Shall be configurable and controllable, with appropriate access authorization, from the remote command center;
- 5.9.3 Shall provide for secure communications that meet system security policies using Federal Information Processing Standards (FIPS) 140 compliant cryptographic modules for encryption of all communications with the external network; and
- 5.9.4 Should utilize widely accepted communication protocols, such as the National Information Exchange Model (NIEM) N25 for CBRNE.

5.10 *Radioactive Material, if applicable:*

- 5.10.1 An SPCVD that contains radioactive materials shall contain radioactive materials only in quantities that qualify for an exempt materials license per the Nuclear Regulatory Commission Title 10 of the Code of Federal Regulations, Part 30.20.

6. Environmental Requirements

6.1 The SPCVD should be designed for specific climates and environments such as indoor, temperate, low temperature, high temperature, high humidity, high altitude, marine. Manufacturers shall document the climates and environments for which the SPCVD has been designed.

6.2 For the manufacturer-documented capabilities, the SPCVD shall be tested for resistance to degradation or malfunction caused by environmental factors such as: solar radiation, shock, vibration, ingress of moisture and dust, salt environments, altitude, and electromagnetic interference. The test conditions and test results shall be documented.

6.3 These tests shall be conducted using consensus standards, government standards, and other international standards; for examples, see [Appendix X3](#).

6.4 *Electromagnetic Compatibility:*

6.4.1 *Radio Frequency (RF) Immunity*—The SPCVD should be immune to:

- 6.4.1.1 RF fields over the frequency range of 80 MHz to 2500 MHz at an intensity of 10 V/m; and
- 6.4.1.2 RF interference from devices known to be installed nearby or operated in the same facility.

6.4.2 *Radiated Emissions*—The SPCVD should:

- 6.4.2.1 Be compliant with Code of Federal Regulation (CFR) Title 47 Part 15 and Part 18; and
 - 6.4.2.2 Not interfere with other devices installed nearby or operated in the same facility.
- 6.4.3 Electrostatic Discharge (ESD):

6.4.3.1 The SPCVD shall be unaffected by exposure to electrostatic discharge at intensities of up to 6 kV using the contact discharge technique.

6.4.4 Conducted Immunity:

6.4.4.1 The SPCVD shall be immune to conducted RF interference at the installed location.

6.5 *Vibration and Shock*—The SPCVD:

- 6.5.1 Shall function normally when exposed to the mechanical shock environment of the installed location;
- 6.5.2 Shall function normally when exposed to the vibration environment of the installed location; and
- 6.5.3 Should function normally when exposed to low intensity sharp shocks.

6.6 *Moisture and Dust Protection:*

- 6.6.1 The SPCVD shall meet the requirements stated for the ingress protection (IP) code 54 per International Electrotechnical Commission (IEC) 60529; and
- 6.6.2 The SPCVD shall withstand the effects of rain, if applicable.

6.7 *Solar Radiation (if applicable):*

- 6.7.1 The SPCVD shall operate while exposed to the heating effects of direct solar radiation that may occur during any 24 h period; and
- 6.7.2 The enclosure and any exposed components should withstand and not degrade due to the effects of extended exposure to direct solar radiation.

7. Manuals and Documentation

7.1 The accompanying manuals may be provided in print or electronic media, or both, in any appropriate format.

7.2 The SPCVD manuals shall include:

- 7.2.1 Installation manual;
- 7.2.2 User manuals shall describe:
 - 7.2.2.1 Manufacturer-documented baseline chemical detection and additional optional capabilities (Section 4);
 - 7.2.2.2 Climate range(s) (see [Table 2](#));
 - 7.2.2.3 Power requirements;
 - 7.2.2.4 Hardware;
 - 7.2.2.5 Software;
 - 7.2.2.6 Accessories;
 - 7.2.2.7 Instructions for normal operations, special operations, and restrictions;
 - 7.2.2.8 Consumables and the replacement frequency per number of operating hours, replacement frequency per number of non-operating hours, and packaged shelf life of the consumable;
 - 7.2.2.9 Calibration frequency and associated consumables required for calibration;
 - 7.2.2.10 Description of all alarms and indicators;
 - 7.2.2.11 Recommended decontamination procedures;
 - 7.2.2.12 Recommended hazardous waste disposal procedures for the consumables;
 - 7.2.2.13 Explanation of the controls and connectors;
 - 7.2.2.14 Description of software, data communications and data; and
 - 7.2.2.15 Warning statements.