



Designation: A1045 – 10 (Reapproved 2021)

Standard Specification for Flexible Poly (Vinyl Chloride) (PVC) Gaskets Used in Connection of Vitreous China Plumbing Fixtures to Sanitary Drainage Systems¹

This standard is issued under the fixed designation A1045; the number immediately following the designation indicates the year of original adoption or, in the case of revision, the year of last revision. A number in parentheses indicates the year of last reapproval. A superscript epsilon (ϵ) indicates an editorial change since the last revision or reapproval.

1. Scope

1.1 This specification covers material and performance requirements for plasticized PVC compression gaskets used in the connection of residential and commercial vitreous china plumbing fixtures to 2-, 3-, and 4-in. sanitary drain lines. These type gaskets are inserted into and compress against the inside diameter of the sewer pipe, closet or urinal flange while attaching to the vitreous china plumbing fixture with a flexible adhesive. The result is a gas- and watertight seal.

1.2 The values stated in inch-pound units are to be regarded as standard. The values given in parentheses are mathematical conversions to SI units that are provided for information only and are not considered standard.

1.3 *This standard does not purport to address all of the safety concerns, if any, associated with its use. It is the responsibility of the user of this standard to establish appropriate safety, health, and environmental practices and determine the applicability of regulatory limitations prior to use.*

1.4 *This international standard was developed in accordance with internationally recognized principles on standardization established in the Decision on Principles for the Development of International Standards, Guides and Recommendations issued by the World Trade Organization Technical Barriers to Trade (TBT) Committee.*

2. Referenced Documents

2.1 *ASTM Standards:*²

A644 Terminology Relating to Iron Castings

D5926 Specification for Poly (Vinyl Chloride) (PVC) Gaskets for Drain, Waste, and Vent (DWV), Sewer, Sanitary, and Storm Plumbing Systems

2.2 *ASME Standards:*³

ASME A112.19.2M Vitreous China Plumbing Fixtures

3. Terminology

3.1 *Definitions*—For definitions of terms in this specification, refer to Terminology **A644**.

3.2 *Definitions of Terms Specific to This Standard:*

3.2.1 *closet flange, n*—a pipe fitting that secures the water closet to the floor and the sanitary drain line.

3.2.2 *urinal, n*—a plumbing fixture that receives only liquid body waste and, on demand, conveys the waste through a trap seal into a gravity drainage system.

3.2.3 *urinal flange, n*—a pipe fitting that secures a rear outlet wall-mounted urinal to the sanitary drain line.

3.2.4 *vitreous china plumbing fixture, n*—urinal, water closet, or both.

3.2.5 *water closet, n*—a plumbing fixture having a water-containing receptor which receives liquid and solid body waste and upon actuation conveys the waste through an exposed integral trap seal into a gravity drainage system.

4. Materials and Manufacture

4.1 These type gaskets are manufactured principally from virgin injection-grade plasticized PVC compounds. Recycled materials may be used in this product in accordance with Section 5.

4.2 Adhesives used in the attachment of vitreous china plumbing fixture gaskets shall be compatible with the component gasket material and the sanitary drain system. Butyl rubber-based adhesives are known to have such characteristics.

5. Gasket Requirements

5.1 Physical and mechanical properties of plasticized PVC gaskets for the connection of vitreous china plumbing fixtures to the sanitary drainage system shall comply with Specification **D5926**.

¹ This specification is under the jurisdiction of ASTM Committee **A04** on Iron Castings and is the direct responsibility of Subcommittee **A04.75** on Gaskets and Coupling for Plumbing and Sewer Piping.

Current edition approved Oct. 1, 2021. Published October 2021. Originally approved in 2005. Last previous edition approved in 2017 as A1045 – 10 (2017). DOI: 10.1520/A1045-10R21.

² For referenced ASTM standards, visit the ASTM website, www.astm.org, or contact ASTM Customer Service at service@astm.org. For *Annual Book of ASTM Standards* volume information, refer to the standard's Document Summary page on the ASTM website.

³ Available from American Society of Mechanical Engineers (ASME), ASME International Headquarters, Two Park Ave., New York, NY 10016-5990, <http://www.asme.org>.

5.2 Gaskets shall be tested in accordance with Section 9 on pipe samples complying with applicable industry standards of maximum and minimum dimensions. It shall be permissible to machine pipe samples to attain maximum or minimum dimensions, or both.

5.3 The gasket assembly when tested in accordance with Section 9 shall not leak.

5.4 The gasket shall accommodate vitreous china plumbing fixtures and flanges conforming to applicable industry standards.

6. Dimensions, Mass, and Permissible Variations

6.1 Gaskets shall conform to the dimensions and dimensional tolerances as agreed upon between the supplier and purchaser. All dimensions shall be compatible with the dimensions and tolerances of the specific pipe materials and sizes and vitreous china plumbing fixture to which it is designed to join.

7. Workmanship, Finish, and Appearance

7.1 The surface of preformed gaskets shall be smooth and free from pitting, cracks, blisters, air marks, or any other imperfections that may affect product performance in service.

7.2 Neither the flash thickness nor the flash extension shall exceed $\frac{1}{32}$ in. (1 mm).

7.3 Mold release, oil, or grease used in the manufacturing process will have a detrimental effect on the ability of the adhesive to adhere to the flanged surface of the fixture gasket. Care should be taken not to contaminate the flanged surface of the gasket.

8. Sampling, Tests, and Retests

8.1 Test specimens representative of the gaskets to be used shall be randomly selected from the manufactured lot for testing. The manufactured lot shall be a minimum of eight hours old. Tests shall be performed at room temperature.

8.2 Where there is a failure in the original test, the entire test shall be rerun with twice the number of samples and any failure shall be cause for rejection.

9. Test Method for Assembled Gaskets

9.1 *Test Apparatus*—The apparatus used to conduct this test shall be designed according to the applicable outlet dimensions of the vitreous china plumbing fixture. See Fig. 1 for example.

The test apparatus shall be constructed of clear acrylic with a polished finish.

9.2 *Significance and Use*—This test method is useful in determining the ability of the gasket assembly to provide a permanent seal against water, sewer, sewer gas, and the like in vitreous china plumbing fixture to sanitary drain line connections.

9.3 *Hazards*—This is a pressurized hydrostatic test and under no circumstances shall water be substituted with air. Care should be taken in expelling all air prior to pressurizing the test assembly. Wear eye protection during pressure tests and strictly adhere to safety precautions at all times.

9.4 *Procedure – Hydrostatic Joint Tightness Test*—Wipe the surface of the test apparatus with denatured alcohol. Apply the gasket assembly to the test apparatus. Insert the test apparatus assembly into the test pipe, providing an adequate space between the test apparatus and the flange to prohibit compression of the gasket between the test apparatus and flange. Securely tighten the test apparatus to the flange, fill the assembly with water expelling all air, pressurize to 4.3 psi for a period of 15 min. Any leakage shall result in failure. Refer to Fig. 2.

10. Certification

10.1 The gasket manufacturer shall keep appropriate production and testing records showing compliance to this specification, including certified documentation from the PVC compound producer showing compliance with Specification D5926. The manufacturer shall be required to provide said information at the request of the purchaser.

11. Product Marking

11.1 Each gasket shall be marked with the manufacturer's name or trademark, or both.

11.2 The type and size of pipe for which the gasket is or the manufacturer's product identification shall be marked on or attached to each gasket.

11.3 All gaskets shall be marked with the designation ASTM A1045 showing compliance to this specification.

12. Keywords

12.1 closet flange; flexible gaskets; plasticized; plumbing fixtures; poly(vinyl chloride) (PVC); sanitary drainage; toilet seal; urinal; urinal flange; urinal seal; vitreous china; vitreous china plumbing fixtures; water closet gaskets

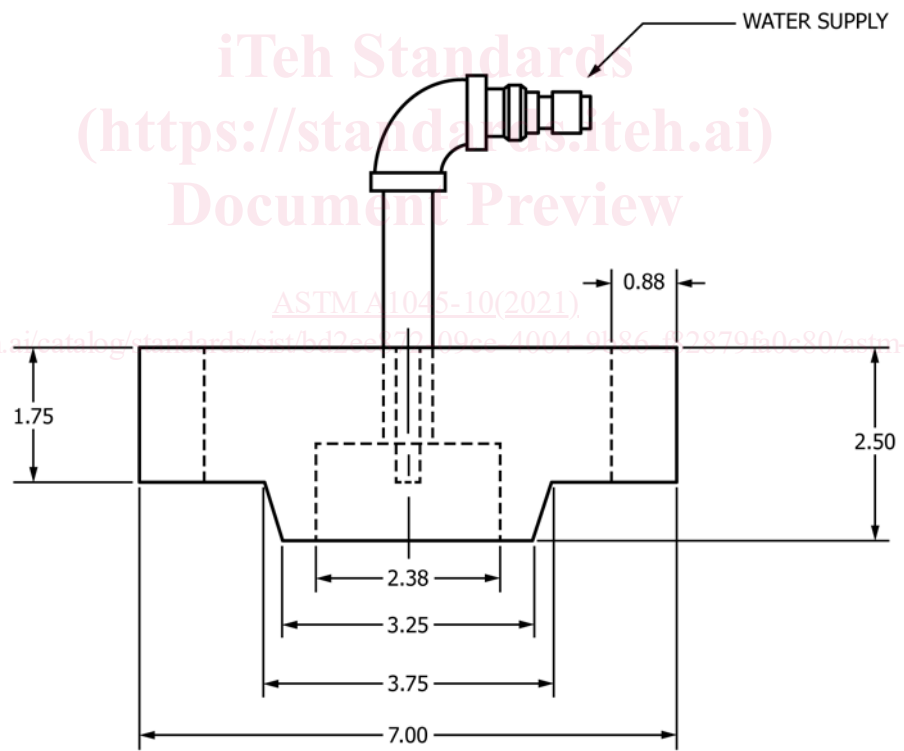
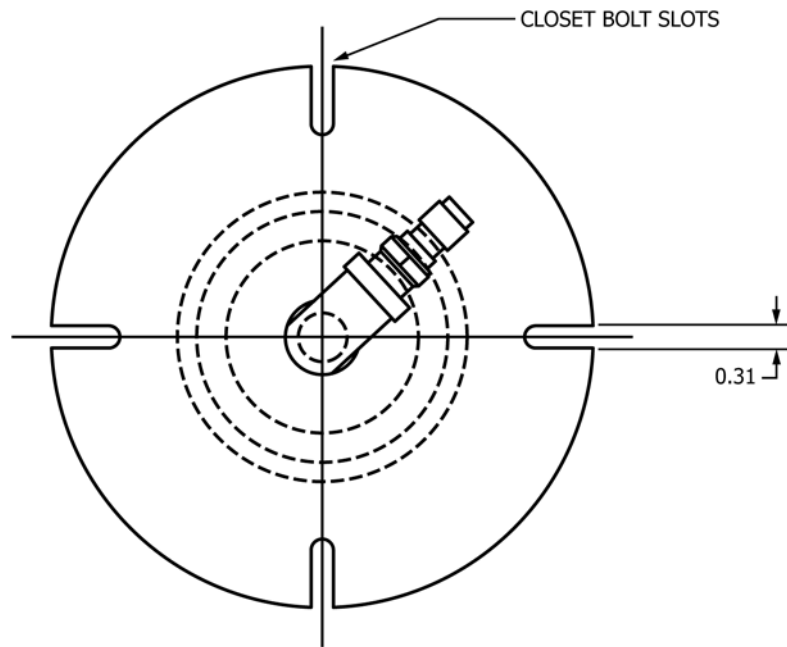

FIG. 1 Test Apparatus (Typical Water Closet Configuration)