



Continuous mechanical handling equipment — Chain conveyors with bearing devices or load carriers — Examples of protection against injuries by load carriers

Engins de manutention continue — Convoyeurs à chaînes avec dispositifs porteurs ou systèmes d'entraînement — Exemples des mesures de protection contre les accidents corporels provoqués par les pousseurs ou systèmes d'entraînement

Technical Report 5047 was drawn up by sub-committee 2 *safety* of ISO/TC 101 *Continuous mechanical handling equipment*, and approved by the majority of its members.

The aim of this technical report is to give examples for safety at load carriers of chain conveyors.

It incorporates sketches which show in principle how sufficient safety can be achieved without excluding other methods which give the same safety factor. As this a subject, that cannot be considered as suitable for an International Standard, it was decided to publish the document as a Technical Report.

<https://standards.iteh.ai/catalog/standards/sist/9b4dad2f-9214-413c-b036-b4805f491f09/iso-tr-5047-1982>

1 Scope and field of application

This Technical Report gives examples of the various kinds of hazards connected with chain conveyors with supporting rods or rollers, push rods, single load carriers etc, suitable clearances as well as other safety measures and devices.

This Technical Report explains the various safety standards for loose materials and unit loads. It incorporates principal sketches which show how sufficient safety can be reached without excluding other methods, which give the same safety factor. The remarks apply also to jointed apron conveyors especially in respect of external pressure edges, where crushing can take place.

2 References

ISO 1819, *Continuous mechanical handling equipment — Safety code — General rules*.

ISO 2148, *Continuous mechanical handling equipment — Nomenclature*.

UDC 621.867.1 : 614.8

Ref. No. : ISO/TR 5047-1982 (E)

Descriptors : handling equipment, continuous handling, conveyors, chain conveyors, safety requirements.

© International Organization for Standardization, 1982 •

3 Danger points

3.1 Dangers at load carriers

Dangers of crushing and shearing on chain conveyors with push rods, load carriers, supporting arms etc arise when the load carriers are fitted at too small a distance from the sliding surface or when there are shear traps, so that parts of the body can get into danger points creating a hazard of shearing off, crushing or bones fractures.

3.1.1 Trapping on sliding surfaces

If the distance (a_x) between the load carriers and the sliding surface is too small, there arises the danger of trapping (hands, feet or head), see 4.1.

In the case of square or rectangular rods and continuous sliding surfaces there is no danger when a is less than 5 mm.

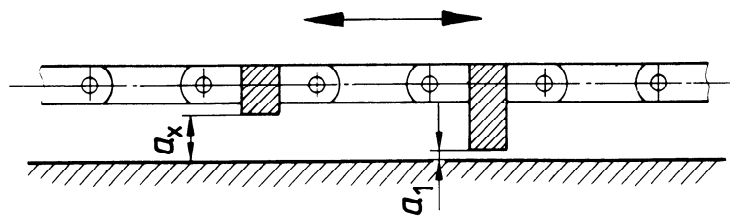

iTeh STANDARD PREVIEW

3.1.2 Shearing trap at end of sliding surface

(standards.iteh.ai)

If there are breaks in the sliding surface there are shearing traps when the load carriers run on to the sliding surface (A).

The same applies when the sliding surface has openings in it (for example intermediate discharge point).

ISO/TR 5047:1982

https://standards.iteh.ai/catalog/standards/sis/9b4dad2f-9214-4159-b050-

b4805f491f09/iso-tr-5047-1982

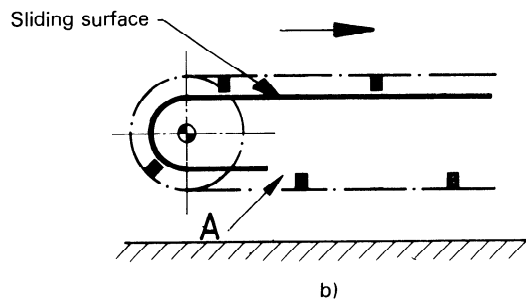
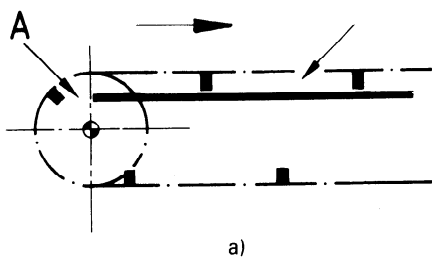

3.1.3 Dangers at inside fixtures

If supporting rods and rollers are fitted too near to the diagonal trussing (A) or support rollers (B) or distance plates (C), there is the danger of crushing or shearing. The hands are mainly endangered.

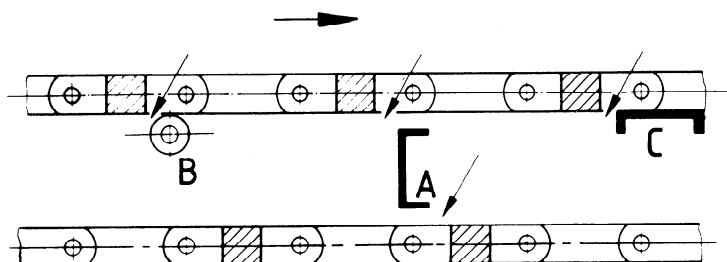

3.1.4 Dangers at outside fixtures

Outside edges are created by outside lateral strutting (A) by the trough of the conveyor itself (B), by parts of machinery or building in which the conveyors are installed (C) and also by turned in edges of protective covers (D). These traps are within easy reach, and according to position and installation can constitute a hazard to all parts of the body. Special attention should be paid to the tensioning points.

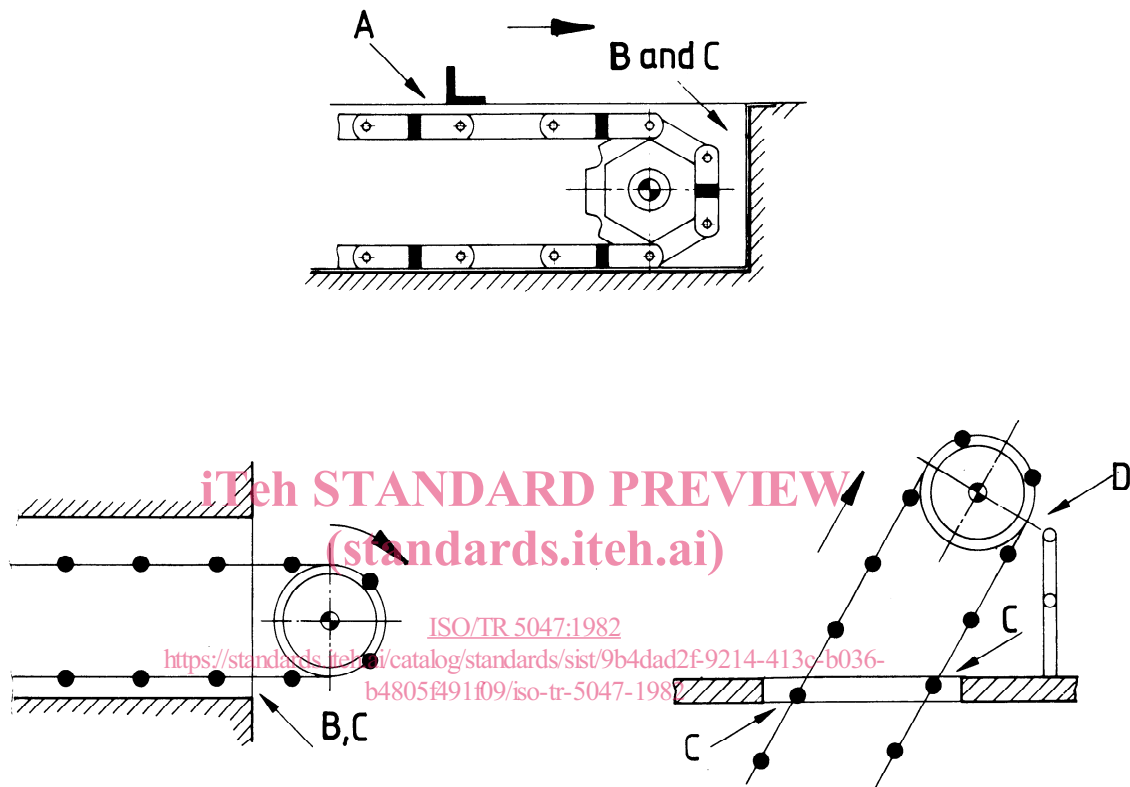

iteh STANDARD PREVIEW
(standards.iteh.ai)

ISO/TR 5047:1982

<https://standards.iteh.ai/catalog/standards/sist/9b4dad2f-9214-413c-b036-b4805f491f09/iso-tr-5047-1982>

3.1.5 Dangers between carrying and return strands

If the carrying and returning strands run near each other, there is the danger of hands being trapped if a safe clearance is not maintained (A), see 4.1.

In addition, in certain circumstances there is a possibility of bone fracture if the hands are bent backwards (B). The relation between the free space, f , and distance, g , is important. The most dangerous condition arises when the ball of the hand is trapped between the rollers. The following relation between the values f and g should be observed.

f mm	0 to 15	15 to 70	> 70
g mm		120	80

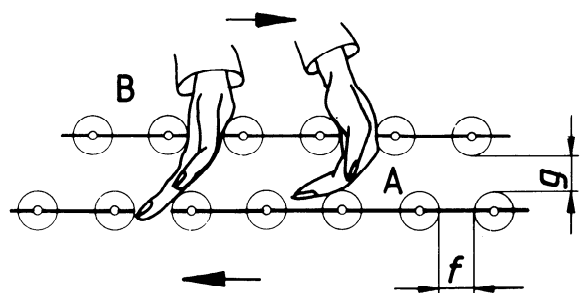

3.1.6 Shearing dangers

With conveyors which appear easy to step over, there arises an additional shearing danger (A) because a foot creates an additional fixed point due to frictional resistance on the ground (B).

There arises in addition to the existing possibility of crushing (see 3.1.3) a fall into the installation with ensuing injuries too difficult to estimate. There can be a hazard to both limbs.

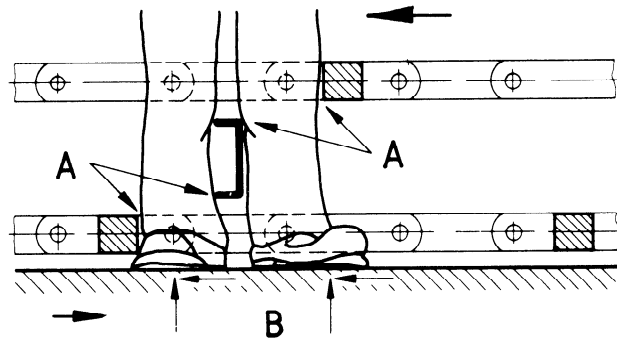

3.1.7 Dangers when the load carriers pass through the sliding surface

At the end of the conveyor the load carriers must pass through the plane of the moving goods A.

When that takes place from below to above, the danger points are usually covered. At the discharge however, the danger point is almost always accessible.

ISO/TR 5047:1982

According to its location, all parts of the body are exposed to danger.

Jump out rollers at the discharge end offer no solution in the case of crushing, as the pressure works from top to bottom (B).

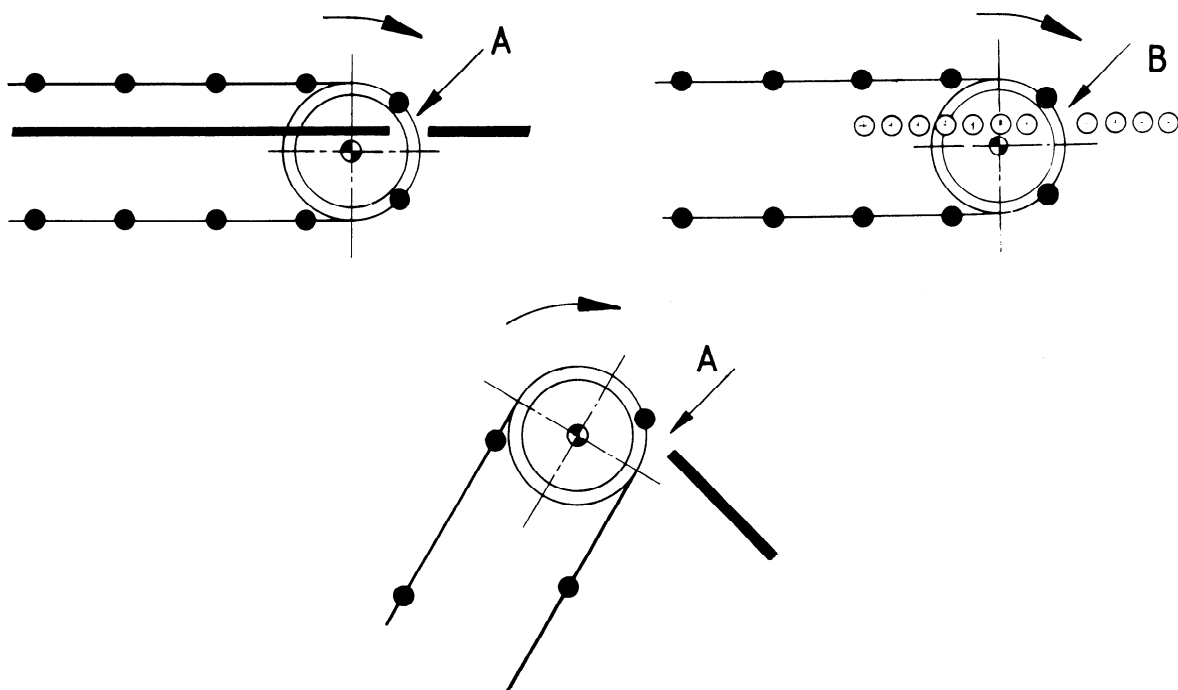

3.2 Parts of the body exposed to danger

If the clearances are smaller than the safety clearances prescribed the possibility of dangerous trapping arises.

The dimensions of the clearances depend on which part of the body is in danger.

The possibility of trapping depends on:

- the position of the conveyor in relation to the work stations;
- the dimensions of the conveyor;
- the type of construction, for example of the conveyor's strand;
- the shape of the load carriers.

3.2.1 Dangers related to the position of the conveyor

The location of the dangerous points in relation to passageways and operating positions will determine the extent of the danger.

In addition to the foregoing, further conditions must be examined (see 3.2). Depending on the height h between the underside of the loading end and the surface of movement or places of standing there arises, in relation to the upper or under side of conveyor a danger of crushing for the following parts of the body at the existing trapping points.

3.2.1.1 Horizontal conveyor

- Crushing traps on the upper edges

These points are accessible from the floor level if it is not possible to step on the conveyor.

h_1 from floor level to 2,2 m for the hands

h_1 up to 1 m for the feet

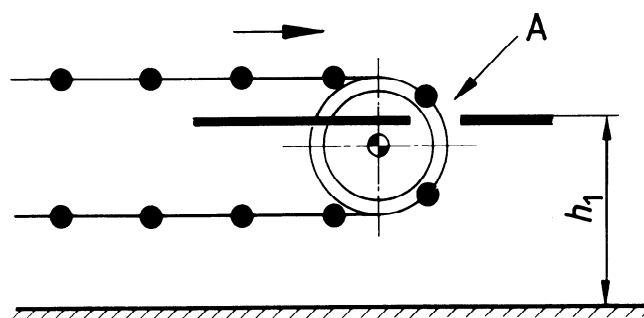

- Crushing traps on the underside

These points can only be reached if they are accessible from the front or from the sides. h_3 is the clearance between the underside of the sliding surface and the floor and the dangerous part A is not accessible providing it is not possible to reach under the side guards or covered construction.

The possibility of access to the dangerous parts should be considered separately for the sides, h_2 , and the front, h_3 , because the widths for access are different.

h_2 or $h_3 > 80$ mm if no hazard;

$80 \text{ mm} \leq h_2$ or $h_3 \leq 300$ mm if hazard for arms;

h_2 or $h_3 > 300$ mm if hazard for the head (as well as the arm or hands).

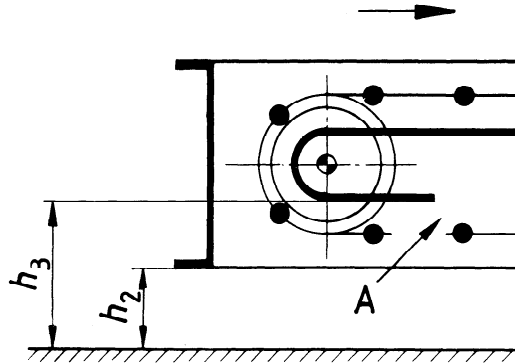

3.2.1.2 Vertical or sloping conveyor

iTeh STANDARD PREVIEW
(standards.iteh.ai)

a) On upward strand

The dangerous parts can be reached when:

- h is less than 2,2 m for the hands.
- h_4 is less than 1 m for the feet.

ISO/TR 5047:1982

<https://standards.iteh.ai/catalog/standards/sist/9b4dad2f-9214-413c-b036-b4805f491f09/iso-tr-5047-1982>

b) On downwards strand

The dangerous parts can be reached when:

- h_5 over 2,2 m hazard for hands.
- h_5 from 1,8 m to 2,2 m hazard for arms.
- h_5 up to 1,8 m hazard for the head, hands and arms.

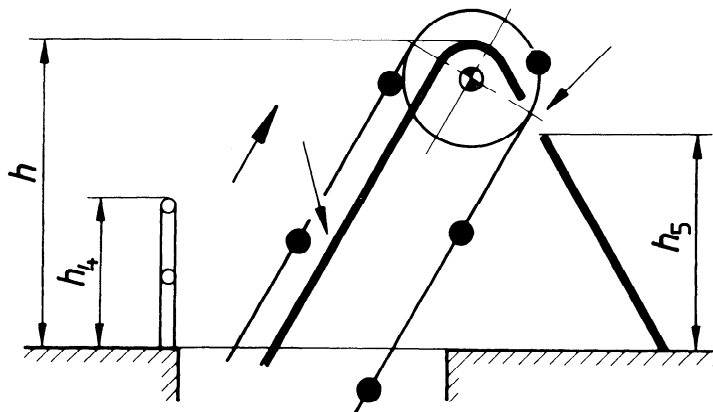

3.2.2 Reducing the danger by dimensions or lay out

Independently of the position of the conveyor it must be stable as depending on the dimensions persons can stand on it.

It should be forbidden to step on conveyors at 160 mm width or less.

It is further considered if by surrounding the conveyors by machinery (for example packing machinery, etc.) or by parts of building for example, covered duct, then the lay out can prevent walking on the conveyor.

3.2.3 Hazards caused by the shape of load carriers

3.2.3.1 Load carriers shaped liked prongs with sharp points, as used for example on conveyors for moving bales of hay, represent a hazard and should be used when no other solution is practicable.

They also introduce traps between themselves and fixed parts of the machine or adjacent structure, as shown at D. Furthermore, there is a trap between the prongs and the entrance to the guard at E, if the height h_6 to this trap is less than 2,50 m above operating level.

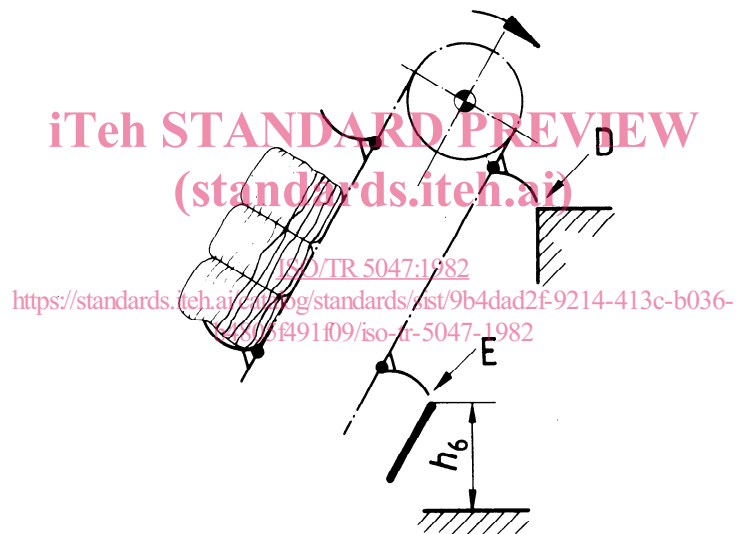

3.2.3.2 For solid load carriers with rectangular cross-section, see 3.2.1

3.2.3.3 For solid load carriers with a circular cross section and for roller load carriers, there is a risk of hands being trapped when the clearance between the sliding surface and rollers is smaller than 5 mm. In these circumstances, the minimum specified clearance for the endangered part of the body should be provided.

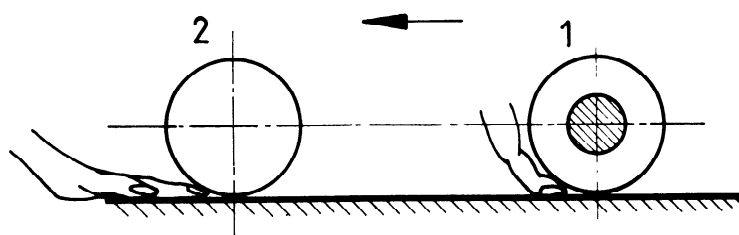

3.2.3.4 Small load carriers which have no cross connection to any other chain constitute a hazard to fingers only, if the carriers (A) are not larger than 20 mm.

In addition, hand injuries are possible if the fingers can bridge the gap, *b*.

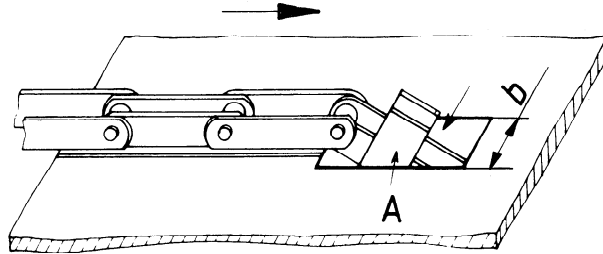

4 Safety measures

Adequate safety at the following danger points illustrated in the following sub-clauses can be achieved in accordance with the previously mentioned standards and, depending on which parts of the body are exposed to danger by means of :

- a) maintaining the required safety clearances;
- b) re-designing of the danger points;
- c) fencing;
- d) special safety devices.

ITeH STANDARD PREVIEW
(standards.iteh.ai)
<https://standards.iteh.ai/catalog/standards/sist/9b4dad2f-9214-413c-b036-b4805f491f09/iso-tr-5047-1982>

4.1 Safety clearances

The following safety clearances prevent danger to the part of the body stated.

- a_1 smaller than 5 mm for going sliding surfaces;
- a_2 greater than 20 mm for fingers;
- a_3 greater than 50 mm for hands;
- a_4 greater than 80 mm for forearms;
- a_5 greater than 120 mm for legs and feet;
- a_6 greater than 500 mm for head and trunk.

4.2 Re-designing of the danger points

If the safety clearances interfere with the operation of the installation :

- it can be raised to make the dangerous parts inaccessible;
- the dangerous points can be fenced;
- railings can be fitted,

so there is sufficient clearance for the part of the body that has access.

When railings are fitted, access through the bars must be taken into consideration.

4.3 Fencing

If it is not possible to provide adequate safe clearances according to 4.1 and 4.2, suitable fencing must be fitted.

4.3.1 Fencing must be so fitted and erected that it is not possible to reach round or through it. The distance, e , should be 850 mm minimum. Access to the dangerous parts can be prevented by ensuring sufficient height of the guard relative to the ground or other operating levels.

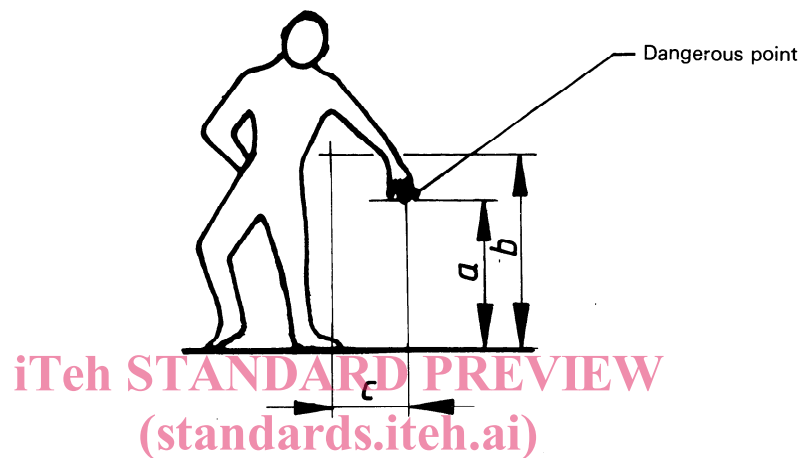

ISO/TR 5047:1982

<https://standards.iteh.ai/catalog/standards/sist/9b4dad2f-9214-413c-b036-b4805f491f09/iso-tr-5047-1982>

Dimensions in millimetres

Height of dangerous point relative to the ground or other operating levels, a	Height bar of guard, b							
	2 400	2 200	2 000	1 800	1 600	1 400	1 200	1 000
Horizontal distance of guard from dangerous point, c								
2 400	—	100	100	100	100	100	100	100
2 200	—	250	350	400	500	500	600	600
2 000	—	—	350	500	600	700	900	1 100
1 800	—	—	—	600	900	900	1 000	1 200
1 600	—	—	—	500	900	900	1 000	1 300
1 400	—	—	—	100	800	900	1 000	1 300
1 200	—	—	—	—	500	900	1 000	1 400
1 000	—	—	—	—	300	900	1 000	1 400
800	—	—	—	—	—	600	900	1 300
600	—	—	—	—	—	—	500	1 200
400	—	—	—	—	—	—	300	1 200

1) No dimensions for b less than 1 000 mm are counted as they would be a danger of tilting into the dangerous area.

4.3.2 A three sided enclosure gives adequate protection provided the clearance, e , is maintained.

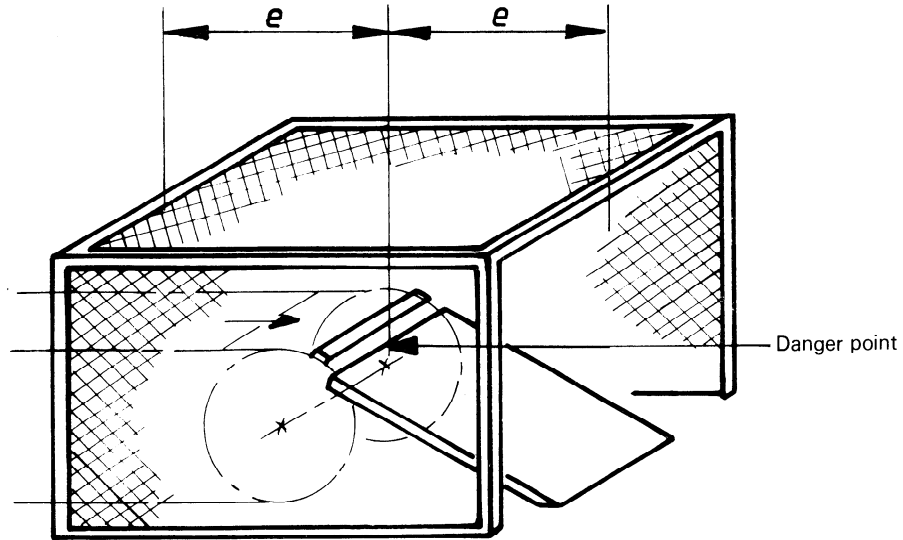

iTeh STANDARD PREVIEW

4.3.3 Guards for the pointed prongs described in 3.2.3.1 should be mounted on the side of the conveyor, not more than 60 mm from the edge of the prongs, and should extend beyond the prongs by at least 30 mm.

Such guards also protect against the dangers arising at points D and E (see sketch in 3.2.3.1).

ISO/TR 5047:1982
<https://standards.iteh.ai/catalog/standards/sist/9b4dad2f-9214-413c-b036-b4805f491f09/iso-tr-5047-1982>

Dimensions in millimetres

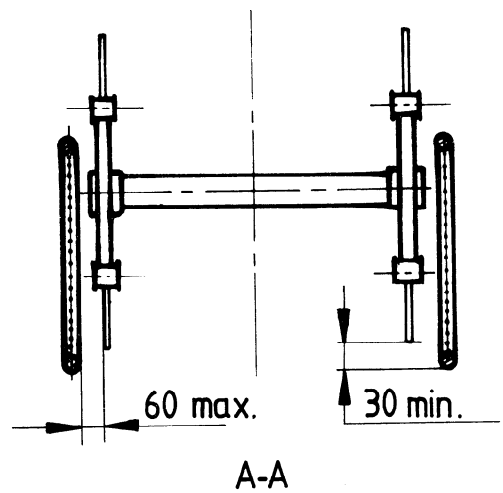
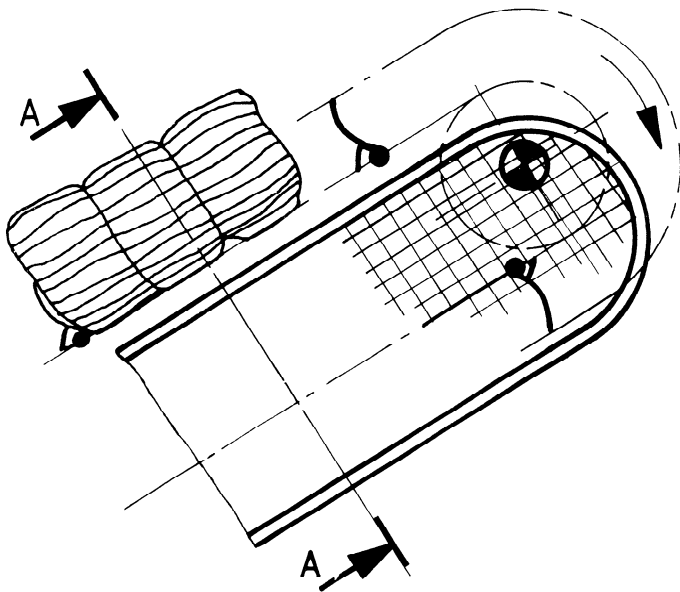

4.4 Examples of special safety devices

4.4.1 Filler plank protection

A guard such as a filler plank (F) with a sloping deflection edge (G) can be fitted between the prongs or load carriers (Z), adjacent to the chains.

The guard should extend at least 10 mm beyond the prongs or load carriers. The distance, g , between the ends of the prongs or load carriers and the anchorage (H) for the guard should be at least 30 mm. When single prongs or load carriers are used, the guards should be along side the run of them.

