



SLOVENSKI STANDARD

SIST ISO 5049-1:1997

01-marec-1997

Mobilne naprave za kontinuirni transport sipkih materialov - Pravila za konstruiranje jeklenih konstrukcij

Mobile equipment for continuous handling of bulk materials -- Part 1: Rules for the design of steel structures

iTeh STANDARD PREVIEW

Appareils mobiles de manutention continue pour produits en vrac -- Partie 1: Règles pour le calcul des charpentes en acier

[SIST ISO 5049-1:1997](https://standards.iteh.ai/catalog/standards/sist/5659e9b3-28fd-4cfd-a4ad-31c39215bf61/sist-iso-5049-1-1997)

Ta slovenski standard je istoveten z: **ISO 5049-1:1994**

ICS:

53.040.01	Oprema za neprekinjen transport na splošno	Continuous handling equipment in general
-----------	--------------------------------------------	------------------------------------------

SIST ISO 5049-1:1997

en

iTeh STANDARD PREVIEW
(standards.iteh.ai)

SIST ISO 5049-1:1997

<https://standards.iteh.ai/catalog/standards/sist/5659e9b3-28fd-4cfd-a4ad-51e59215bfc1/sist-iso-5049-1-1997>

INTERNATIONAL
STANDARD

ISO
5049-1

Second edition
1994-07-01

**Mobile equipment for continuous handling
of bulk materials —**

Part 1:

Rules for the design of steel structures

(standards.iteh.ai)

Appareils mobiles de manutention continue pour produits en vrac —

Partie 1: Règles pour le calcul des charpentes en acier



Reference number
ISO 5049-1:1994(E)

ISO 5049-1:1994(E)

Contents

	Page
1 Scope	1
2 Normative references	1
3 Loads	1
3.1 Main loads	2
3.2 Additional loads	4
3.3 Special loads	8
4 Load cases	9
5 Design of structural parts for general stress analysis	10
5.1 General	10
5.2 Characteristic values of materials	10
5.3 Calculation of allowable stresses with respect to the yield point	11
5.4 Checking of framework elements submitted to compression loads	11
6 Design of joints for general stress checking	13
6.1 Welded joints	13
6.2 Bolted and riveted joints	15
6.3 Joints using high-strength friction-grip (HSFG) bolts with controlled tightening	17
6.4 Cables	20
7 Calculation of allowable fatigue strength for structural members and for joints	20
7.1 General	20
7.2 Allowable stress, σ_D	20
7.3 Characteristic curves for allowable fatigue strength	21
8 Exceeding allowable stresses	46
9 Safety against overturning	46

© ISO 1994

All rights reserved. Unless otherwise specified, no part of this publication may be reproduced or utilized in any form or by any means, electronic or mechanical, including photocopying and microfilm, without permission in writing from the publisher.

International Organization for Standardization
Case Postale 56 • CH-1211 Genève 20 • Switzerland

Printed in Switzerland

9.1	Checking for safety against overturning	46
9.2	Additional precautions	46
10	Safety against drifting	46
Annex		
A	Bibliography	48

iTeh STANDARD PREVIEW (standards.iteh.ai)

[SIST ISO 5049-1:1997](https://standards.iteh.ai/catalog/standards/sist/5659e9b3-28fd-4cfd-a4ad-51e59215bfc1/sist-iso-5049-1-1997)

<https://standards.iteh.ai/catalog/standards/sist/5659e9b3-28fd-4cfd-a4ad-51e59215bfc1/sist-iso-5049-1-1997>

Foreword

ISO (the International Organization for Standardization) is a worldwide federation of national standards bodies (ISO member bodies). The work of preparing International Standards is normally carried out through ISO technical committees. Each member body interested in a subject for which a technical committee has been established has the right to be represented on that committee. International organizations, governmental and non-governmental, in liaison with ISO, also take part in the work. ISO collaborates closely with the International Electrotechnical Commission (IEC) on all matters of electrotechnical standardization.

Draft International Standards adopted by the technical committees are circulated to the member bodies for voting. Publication as an International Standard requires approval by at least 75 % of the member bodies casting a vote.

International Standard ISO 5049-1 was prepared by Technical Committee ISO/TC 101, *Continuous mechanical handling equipment*.

This second edition cancels and replaces the first edition (ISO 5049-1:1980), of which it constitutes a technical revision.

ISO 5049 consists of the following parts, under the general title *Mobile equipment for continuous handling of bulk materials*:

- Part 1: *Rules for the design of steel structures*
- Part 2: *Rules for the design of machinery*

Annex A of this part of ISO 5049 is for information only.

Mobile equipment for continuous handling of bulk materials —

Part 1:

Rules for the design of steel structures

1 Scope

This part of ISO 5049 establishes rules for determining the loads, types and combinations of loads (main, additional and special loads) which must be taken into account when designing steel structures for mobile continuous bulk handling equipment.

This part of ISO 5049 is applicable to rail-mounted mobile equipment for continuous handling of bulk materials, especially to

- stackers,
 - shiploaders,
 - reclaimers,
 - combined stackers and reclaimers,
 - continuous ship unloaders.
- } equipment fitted with bucket wheels or bucket chains

For other equipment, such as

- excavators,
- scrapers,
- reclaimers with scraper chain,
- mixed tyre or caterpillar-mounted stackers and reclaimers,

the clauses in this International Standard as adapted to each type of apparatus are applicable.

2 Normative references

The following standards contain provisions which, through reference in this text, constitute provisions of this part of ISO 5049. At the time of publication, the editions indicated were valid. All standards are subject to revision, and parties to agreements based on this part of ISO 5049 are encouraged to investigate the possibility of applying the most recent editions of the standards indicated below. Members of IEC and ISO maintain registers of currently valid International Standards.

ISO 286-2:1988, *ISO system of limits and fits — Part 2: Tables of standard tolerance grades and limit deviations for holes and shafts.*

ISO 630:1980, *Structural steels.*

ISO 2148:1974, *Continuous handling equipment — Nomenclature.*

ISO 5048:1989, *Continuous mechanical handling equipment — Belt conveyors with carrying idlers — Calculation of operating power and tensile forces.*

3 Loads

Depending on their frequency, the loads are divided into three different load groups: main loads, additional loads and special loads.

- a) The main loads comprise all the permanent loads which occur when the equipment is used under normal operating conditions.

They include, among others:

- dead loads;
- material loads;
- incrustation;
- normal digging and lateral resistances;
- forces at the conveying elements for the material load;
- permanent dynamic effects;
- inclination of the machine;
- loads on the gangways, stairs and platforms.

- b) The additional loads are loads that can occur intermittently during operation of the equipment or when the equipment is not working; these loads can either replace certain main loads or be added to the main loads.

They include, among others:

- wind load for machines in operation;
- snow load;
- temperature load;
- abnormal digging and lateral resistance;
- resistances due to friction and travel;
- horizontal lateral forces during travelling;
- non-permanent dynamic effects.

- c) The special loads comprise the loads which should not occur during and outside the operation of the equipment but the occurrence of which is not to be excluded.

They include, among others:

- blocking of chutes;
- resting of the bucket wheel or the bucket ladder on the ground or face;
- blocking of travelling devices;
- lateral collision of the bucket wheel with the slope;
- wind load for machines not in operation;

- buffer effects;
- loads due to earthquakes.

In addition, it may be necessary to take into account the loads occurring on certain parts of the structure during assembly.

3.1 Main loads

3.1.1 Dead loads

Dead loads are load forces of all fixed and movable construction parts, always present in operation, of mechanical and electrical plants as well as of the support structure.

3.1.2 Material loads

The material load carried on conveyors and reclaimers is considered.

3.1.2.1 Material load carried on the conveyors

These loads are determined from the design capacity (in cubic metres per hour).

3.1.2.1.1 Units with no built-in reclaiming device

a) Where the belt load is limited by automatic devices, the load on the conveyor will be assumed to be that which results from the capacity thus limited.

b) Where there is no capacity limiter, the design capacity is that resulting from the maximum cross-sectional area of the conveyor multiplied by the conveying speed.

Unless otherwise specified in the contract, the cross-sectional area shall be determined assuming a surcharge angle $\theta = 20^\circ$.

The maximum sections of materials conveyed are calculated in accordance with ISO 5048.

c) Where the design capacity resulting from a) or b) on the upstream units is lower than that of the downstream units, the downstream units may be deemed to have the same capacity as the upstream units.

3.1.2.1.2 Units fitted with a reclaiming device (bucket wheel or bucket chain)

a) Where there is no capacity limiter, the design capacity is 1,5 times the nominal filling capacity of

the buckets multiplied by the maximum number of discharges. In the case of bucket wheels, the factor 1,5, which takes into account the volumes which can be filled in addition to the buckets, can be replaced by taking into account the actual value of nominal and additional filling.

- b) Where there are automatic capacity limiters, the design capacity shall be the capacity thus limited.

Where the unit is intended to convey materials of different densities (for example, coal and ore), safety devices shall be provided to ensure that the calculated load will not be exceeded with the heavier material.

Dynamic load factor:

In order to take into account the dynamic loads which could be applied to the conveyor during transport, the load shall be multiplied by a factor of 1,1.

3.1.2.2 Load in the reclaiming devices

To take into account the weight of the material to be conveyed in the reclaiming devices, it is assumed that

- a) for bucket wheels
- one-quarter of all available buckets are 100 % full;
- b) for bucket chains
- one-third of all the buckets in contact with the face are one-third full;
 - one-third of all the buckets in contact with the face are two-thirds full;
 - all other buckets up to the sprocket are 100 % full.

3.1.2.3 Material in the hoppers

The weight of the material in the hoppers is obtained by multiplying the bulk density of the material by the volume (filled to the brim).

If the weight of the material is limited by reliable automatic controls, deviation from the value given in 3.1.2.2 is permissible.

3.1.3 Incrustation

The degree of incrustation (dirt accumulation) depends on the specific material and the operating conditions prevailing in each given case. The data which

follow shall be taken as guidance. The actual values can deviate towards either higher or lower values.

For storage yard appliances, the values are generally lower, while for other equipment (for example in mines) they shall be taken as minimum values.

Loads due to dirt accumulation shall be taken into account:

- a) on the conveying devices, 10 % of the material load calculated according to 3.1.2;
- b) for bucket wheels, the weight of a 5 cm thick layer of material on the centre of the bucket wheel, considered as a solid disc up to the cutting circle;
- c) for bucket chains, 10 % of the design material load calculated according to 3.1.2, uniformly distributed over the total length of the ladder.

3.1.4 Normal digging and lateral resistances

These forces shall be calculated as concentrated loads, i.e. on bucket wheels as acting at the most unfavourable point of the cutting circle, and on bucket chains as acting at a point one-third of the way along the part of the ladder in contact with the face.

3.1.4.1 Normal digging resistance

The normal digging resistance acting tangentially to the wheel cutting circle or in the direction of the bucket chain (on digging units and, in general, on units for which the digging load is largely uncertain) is obtained from the rating of the drive motor, the efficiency of the transmission gear, the circumferential speed of the cutting edge and the power necessary to lift the material and (in the case of bucket chains) from the power necessary to move the bucket chain.

To calculate the lifting power, the figures indicated in 3.1.2.2 may be used.

For storage yard applications, the above method of calculation may be ignored if the digging resistance of the material is accurately known as a result of tests and if it is known for sure that this digging resistance will not be exceeded during normal operation.

3.1.4.2 Normal lateral resistance

Unless otherwise specified, the normal lateral resistance can be assumed to be 0,3 times the value of the normal digging resistance.

3.1.5 Forces on the conveyor

Belt tensions, chain tensions, etc. shall be taken into consideration for the calculation as far as they have an effect on the structures.

3.1.6 Permanent dynamic effects

3.1.6.1 In general, the dynamic effect of the digging resistances, the falling masses at the transfer points, the rotating parts of machinery, the vibrating feeders, etc. need only be considered as acting locally.

3.1.6.2 The inertia forces due to acceleration and braking of moving structural parts shall be taken into account. These can be neglected for appliances working outdoors if the acceleration or deceleration is less than $0,2 \text{ m/s}^2$.

If possible, the drive motors and brakes shall be designed in such a way that the acceleration value of $0,2 \text{ m/s}^2$ is not exceeded.

If the number of load cycles caused by inertia forces due to acceleration and braking is lower than 2×10^4 during the life-time of the machine, the effects shall be considered as additional loads (see also 3.2.7).

3.1.7 Loads due to inclination of the machine

In the case of inclination of the working level forces will be formed by breaking down the weight loads acting vertically and parallel to the plane of the working level. The slope loads shall be based on the maximum inclinations specified in the delivery contract and shall be increased by 20 % for the calculation.

3.1.8 Loads on the gangways, stairs and platforms

Stairs, platforms and gangways shall be constructed to bear 3 kN of concentrated load under the worst conditions, and the railings and guards to stand 0,3 kN of horizontal load.

When higher loads are to be supported temporarily by platforms, the latter shall be designed and sized accordingly.

3.2 Additional loads

3.2.1 Wind load for machines in operation

During handling, a wind speed of $v_w = 20 \text{ m/s}$ (72 km/h) shall be assumed, unless otherwise speci-

fied because of local conditions. The aerodynamic pressure, q , in kilopascals¹⁾, shall be calculated using the following generally applied formula:

$$q = \frac{v_w^2}{1\ 600}$$

where

v_w is the wind speed in metres per second.

The aerodynamic pressure during the handling operation is then

$$q = 0,25 \text{ kN/m}^2$$

Calculating wind action:

It shall be assumed that the wind can blow horizontally in all directions.

The effect of wind action on a structural element is a resultant force, P , in kilonewtons, the component of which resolved along the direction of the wind is given by the equation

$$P = A \times q \times c$$

where

A is the area, in square metres, presented to the wind by the structural element, i.e. the projected area of the structural element on a plane perpendicular to the direction of the wind;

q is the aerodynamic pressure, in kilonewtons per square metre;

c is an aerodynamic coefficient taking into account the overpressures and underpressures on the various surfaces. It depends on the configuration of the structural elements; its values are given in table 1.

When a girder or part of a girder is protected from the wind by another girder, the wind force on this girder is determined by applying a reducing coefficient η . It is assumed that the protected part of the second girder is determined by the projection of the contour of the first girder on the second in the direction of the wind. The wind force on the unprotected parts of the second girder is calculated without the coefficient η .

1) $1 \text{ kPa} = 1 \text{ kN/m}^2$

The value of this coefficient η will depend on h and b (see figure 1 and table 2) and on the ratio

$$\varphi = \frac{A}{A_e}$$

where

A is the visible area (solid portion area);

A_e is the enveloped area (solid portions + voids);

h is the height of the girder;

b is the distance between the surfaces facing each other.

When, for lattice girders, the ratio $\varphi = A/A_e$ is higher than 0,6, the reducing coefficient is the same as for a solid girder.

Table 1 — Values of the aerodynamic coefficient, c

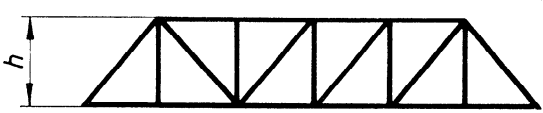
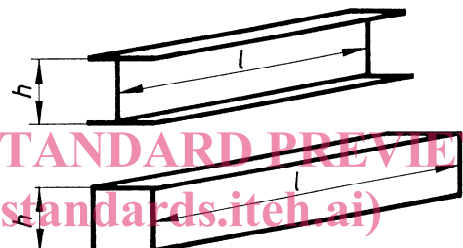
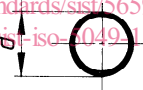
Type of girder		c												
Lattice of rolled sections		1,6												
Solid-web or box girders		for l/h <table style="display: inline-table; vertical-align: middle;"> <tr><td>{</td><td>20</td><td>1,6</td></tr> <tr><td></td><td>10</td><td>1,4</td></tr> <tr><td></td><td>5</td><td>1,3</td></tr> <tr><td></td><td>2</td><td>1,2</td></tr> </table>	{	20	1,6		10	1,4		5	1,3		2	1,2
{	20	1,6												
	10	1,4												
	5	1,3												
	2	1,2												
Members of circular section Tubular lattice	 q (in kilonewtons per square metre)	$d\sqrt{100q} < 1$ 1,2 $d\sqrt{100q} > 1$ 0,7												

NOTE — Certain values of c can be lowered if wind tunnel tests show that the values contained in the table are too high.

Table 2 — Values of reducing coefficient η as a function of $\varphi = A/A_e$ and the ratio b/h

$\varphi = \frac{A}{A_e}$	0,1	0,2	0,3	0,4	0,5	0,6	0,8	1
$b/h = 0,5$	0,75	0,4	0,32	0,21	0,15	0,05	0,05	0,05
$b/h = 1$	0,92	0,75	0,59	0,43	0,25	0,1	0,1	0,1
$b/h = 2$	0,95	0,8	0,63	0,5	0,33	0,2	0,2	0,2
$b/h = 4$	1	0,88	0,76	0,66	0,55	0,45	0,45	0,45
$b/h = 5$	1	0,95	0,88	0,81	0,75	0,68	0,68	0,68

NOTE — These values are also represented by the curves in figure 2.

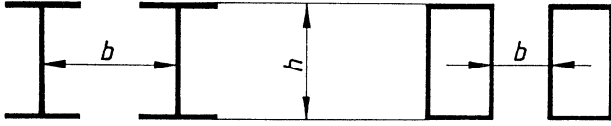

Figure 1 — Height h and width b

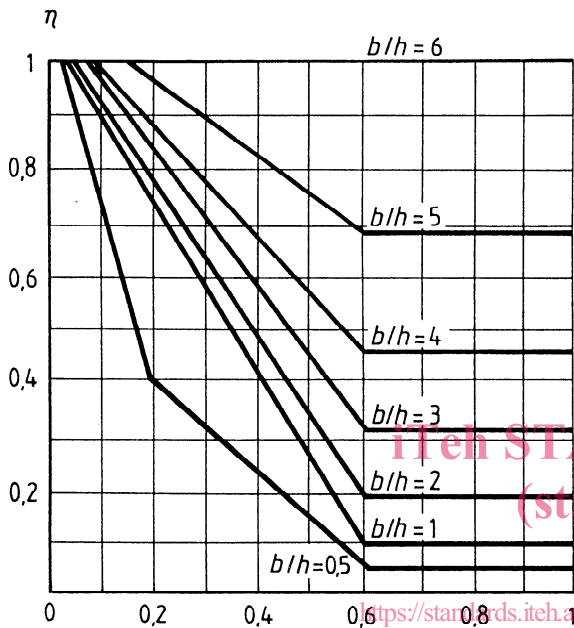

Figure 2 — Curves giving values of η

3.2.2 Snow and ice load

The loads due to snow and ice have been considered by the load case 3.1.3 (incrustation). If the customer does not prescribe load values due to particular climatic conditions, snow and ice need not be included.

3.2.3 Temperature

Temperature effects need only be considered in special cases, for example when using materials with very different expansion coefficients within the same component.

3.2.4 Abnormal digging resistance and abnormal lateral resistance

The abnormal digging resistance acting tangentially to

the bucket wheel or in the direction of the bucket chain is calculated from the starting torque of the drive motor or from the cut-off torque of the built-in safety coupling, taking into account the more unfavourable of the two cases listed below:

a) if the wheel or chain is not loaded:

in this case, account is not taken of the power necessary to lift the material to be transported, and the load due to the starting torque of the motor is considered as a digging load;

b) if the wheel and chain are loaded according to 3.1.2.2:

in this case, the digging power results from the starting torque of the motor, reduced by the lifting power.

The abnormal lateral resistance is calculated as in 3.1.4.2, thereby considering a load of 0,3 times the abnormal digging resistance.

If appropriate, this load can be calculated from the working torque of an existing cut-out device at least equal to 1,1 times the sum of the torques due to the inclination of the machine (see 3.1.7) and to wind load for machines in operation (see 3.2.1).

SIST ISO 5049-1:1997

3.2.5 Resistances due to friction and travel

a) Frictional resistances need only be calculated as long as they influence the sizes.

The friction coefficients shall be calculated as follows:

— for pivots and ball bearings: $\mu = 0,10$

— for structural parts with sliding friction: $\mu = 0,25$

b) For calculating the resistances to travel, the friction coefficients are as follows:

— on wheels of rail-mounted machines: $\mu = 0,03$

— on wheels of crawler-mounted machines: $\mu = 0,1$

— between crawler and ground: $\mu = 0,60$

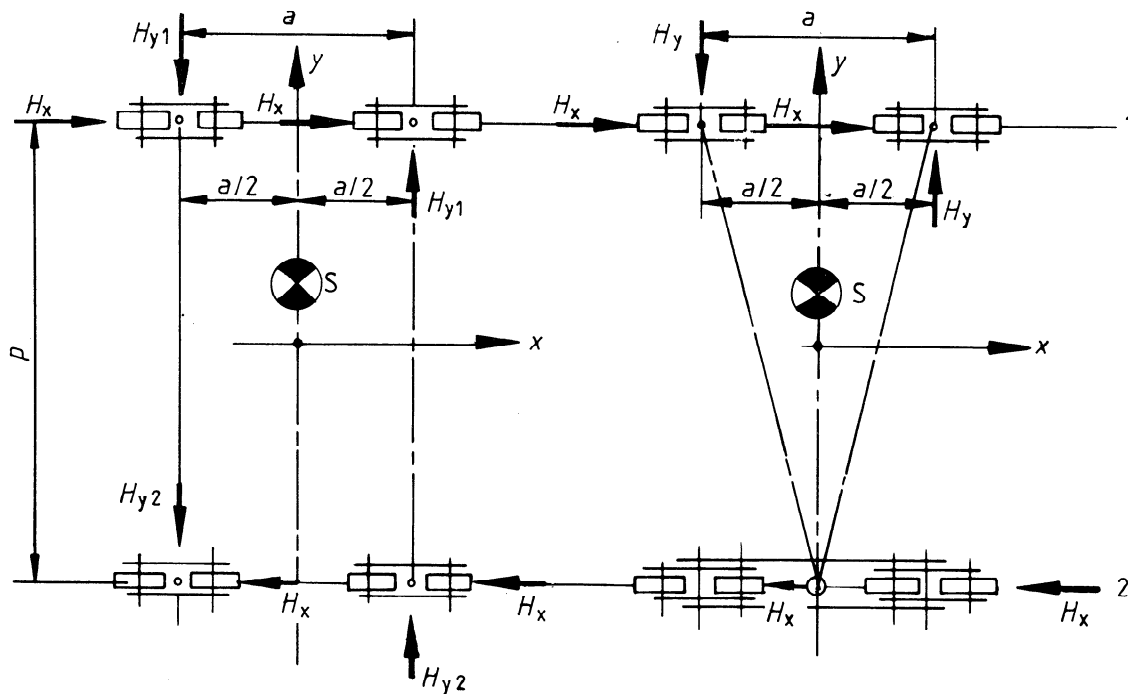

Figure 3 — Appliances on rails
(standards.iteh.ai)

3.2.6 Reactions perpendicular to the rail due to movement of appliance

In the case of appliances on rails which do not undergo any reaction perpendicular to the rail other than those reactions due to wind and forces of inertia, account shall be taken of the reactions resulting from the rolling movement of the unit taking a couple of force H_y directed perpendicularly to the rail as in figure 3.

The components of this couple are obtained by multiplying the vertical load exerted on the wheels or bogies by a coefficient λ which depends on the ratio of the rail gauge, p , to the wheel or bogie wheel base, a .

To calculate the couple H_y , take the centre of gravity S of the appliance on the y -axis in an unfavourable position in relation to sides 1 and 2.

.. there are horizontal guiding wheels, the distance between the guiding wheels shall be taken as value a .

Figure 4 gives the values of λ as a function of the p/a ratio.

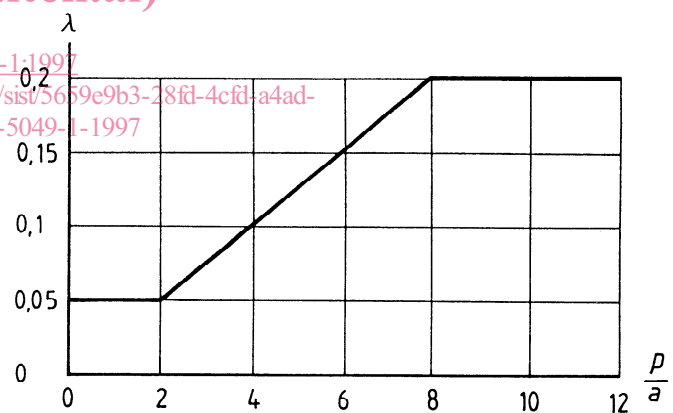

Figure 4 — Values of λ

3.2.7 Non-permanent dynamic effects

The mass forces due to the acceleration and braking of moving structural parts occurring less than 2×10^4 times during the lifetime of the appliance shall be checked as additional loads. They may be disregarded if their effect is less than that of the wind force during operation as per 3.2.1.

If the mass forces are such that they have to be taken into account, the wind effect can be disregarded.

3.3 Special loads

3.3.1 Blockage of chutes

The weight of material due to a blockage shall be calculated using a load which is equivalent to the capacity of the chute in question, with due reference to the angle of repose. The material normally within the chute may be deducted. The actual bulk weight shall be taken for the calculation.

3.3.2 Resting of the bucket wheel or the bucket ladder on the face

Where safety devices, for example slack rope safeguard for rope suspensions or pressure switches for hydraulic hoists, are installed which prevent the full weight of the bucket wheel or the bucket ladder from coming to rest, the allowable resting force shall be calculated as a special load at 1,1 times its value.

Where such safety devices are not provided, the special load shall be calculated with the full resting weight.

3.3.3 Failure of safety devices as in 3.1.2.1

In the case of failure on the part of the automatic safety devices mentioned in 3.1.2.1 to limit the useful loads on the conveyors, the capacity can be calculated as follows:

- in the case of appliances without built-in reclaiming device, according to 3.1.2.1.1 b);
- in the case of appliances with built-in reclaiming device, according to 3.1.2.1.2 a).

For this purpose, account need not be taken of the dynamic factor 1,1.

3.3.4 Locking of travelling devices

For rail-mounted equipment, it shall be taken into account that bogies may be blocked, for example by derailment or rail fracture. For the loads occurring under such conditions, the coefficient of friction between driven wheels and rails shall be taken as $\mu = 0,25$ provided that the drive motors can generate sufficient power.

For equipment mounted on fixed rails, a wheel can be considered as blocked (i.e. unable to rotate but sliding on the rail).

For equipment mounted on movable rails, blocking of a trailing wheel or bogie shall be assumed as due to

derailment or rail fracture. The maximum drive effort of non-blocked wheels shall then be determined. It shall not exceed the friction-transmitted effort between wheels and rails.

3.3.5 Lateral collision with the slope in the case of bucket wheel machines

The maximum lateral resistance in bumping against the slope is determined by the safety coupling in the slewing gear or the kinetic energy of the superstructure. This load shall be applied in accordance with 3.1.4. In calculating the lateral resistance from the kinetic energy, a theoretical braking distance of 30 cm and a constant braking deceleration shall be assumed.

3.3.6 Wind load on non-operating machines

For this case, unless otherwise specified because of local conditions, the wind speeds and aerodynamic pressures given in table 3 shall be taken, with reference to the above ground height of the structural element in question.

Table 3 — Wind speeds and aerodynamic pressures

Above-ground height of the structural element involved	Wind speed		Aerodynamic pressure q
	v_w		
m	m/s	km/h	kN/m ²
2 to 20	36	130	0,8
20 to 100	42	150	1,1
above 100	46	165	1,3

For wind effect calculation, see 3.2.1.

3.3.7 Buffer effects

For horizontal speeds below 0,5 m/s, no account shall be taken of buffer effects. For speeds in excess of 0,5 m/s, account shall be taken of the reaction of the structure to collision with a buffer, when buffering is not made impossible by special devices.

It shall be assumed that the buffers are capable of absorbing the kinetic energy of the machine with operating load up to the rated travelling speed, v_T , as a minimum.

The resulting loads on the structure shall be calculated in terms of the retardation imparted to the machine by the buffer in use.

3.3.8 Loads due to earthquakes

If the delivery contract includes data concerning the effects due to earthquakes, these loads shall be considered in the calculation as special loads.

3.3.9 Erection loads

In certain cases, it may be necessary to check some structural parts under dead loads in particular momentary situations during erection.

4 Load cases

The main, additional and special loads mentioned in clause 3 shall be combined in load cases I, II and III according to table 4.

Only loads which can occur simultaneously and which produce, with the dead weight, the greatest forces at the cutting points, shall be combined.

For case III the most unfavourable combination shall be retained.

Table 4 — Load combinations

Sub-clause	Type of load	Main loads	Main and additional loads	Main, additional and special loads									Erection load
		I	II	III 1	III 2	III 3	III 4	III 5	III ¹⁾ 6	III 7	III 8	III 9	
3.1.1	Dead loads	x	x	x	x	x	x	x	x	x	x	x	x
3.1.2	Material loads on conveyors, reclaiming devices and hoppers	x	x	x	x	x	x	x	x	x	x	x	x
3.1.3	Incrustation	x	x	x	x	x	x	x	x	x	x	x	x
3.1.4	Normal digging and lateral resistances	x		x	x	x	x	x	x	x	x	x	x
3.1.5	Forces on the conveyor	x	x	x	x	x	x	x	x	x	x	x	x
3.1.6	Permanent dynamic effects	x	x	x	x	x	x	x	x	x	x	x	x
3.1.7	Loads due to inclination of machine	x	x	x	x	x	x	x	x	x	x	x	x
3.2.1	Wind load during operation ²⁾		x	x	x	x	x	x		x	x		
3.2.2	Snow and ice (possibly)												
3.2.3	Temperature (possibly)												
3.2.4	Abnormal digging and lateral resistances		x										
3.2.5	Resistances due to friction and travel		x										
3.2.6	Reactions perpendicular to the rail		x										
3.2.7	Non-permanent dynamic effects		x										
3.3.1	Blockage of chutes			x									
3.3.2	Bucket-wheel resting				x								
3.3.3	Failure of safety devices					x							
3.3.4	Locking of travelling device						x						
3.3.5	Lateral collision with the slope (bucket wheel)							x					
3.3.6	Wind load on non-operating machine								x				x
3.3.7	Buffer effects									x			
3.3.8	Loads due to earthquakes										x		
3.3.9	Erection loads (dead loads in particular situations)												x

1) The removal of abnormal digging resistances (see 3.2.4) shall be ensured, when necessary, by appropriate devices (locking device which prevents slewing of appliance when out of service due to wind force).

2) See 3.2.7.