



Designation: ~~D5800~~—~~20~~ D5800 – 21

Standard Test Method for Evaporation Loss of Lubricating Oils by the Noack Method¹

This standard is issued under the fixed designation D5800; the number immediately following the designation indicates the year of original adoption or, in the case of revision, the year of last revision. A number in parentheses indicates the year of last reapproval. A superscript epsilon (ϵ) indicates an editorial change since the last revision or reapproval.

1. Scope*

1.1 This test method covers four procedures for determining the evaporation loss of lubricating oils (particularly engine oils). The evaporation measured is reported as percent total loss. The test method relates to one set of operating conditions but may be readily adapted to other conditions as required.

1.2 Procedure B and Procedure D that are in the main section of the test method provide equivalent results. Procedures A and ~~C~~, which are in [Annex A1](#) and [Annex A2](#), have equivalent results. It has been determined that Procedures A and C show a slight bias when compared to Procedures B and D. Procedures B and D give slightly higher results versus Procedures A and C on formulated engine oils, while Procedures B and D give lower results versus Procedures A and C on basestocks. Thus, a correction factor is utilized to convert between the two sets of Procedures based on the fluid type.

1.3 The values stated in SI units are to be regarded as standard. No other units of measurement are included in this standard.

1.4 *This standard does not purport to address all of the safety concerns, if any, associated with its use. It is the responsibility of the user of this standard to establish appropriate safety, health, and environmental practices and determine the applicability of regulatory limitations prior to use.*

1.5 *This international standard was developed in accordance with internationally recognized principles on standardization established in the Decision on Principles for the Development of International Standards, Guides and Recommendations issued by the World Trade Organization Technical Barriers to Trade (TBT) Committee.*

2. Referenced Documents

2.1 ASTM Standards:²

[D4057 Practice for Manual Sampling of Petroleum and Petroleum Products](#)

[D4177 Practice for Automatic Sampling of Petroleum and Petroleum Products](#)

[D6299 Practice for Applying Statistical Quality Assurance and Control Charting Techniques to Evaluate Analytical Measurement System Performance](#)

[D6300 Practice for Determination of Precision and Bias Data for Use in Test Methods for Petroleum Products, Liquid Fuels, and Lubricants](#)

2.2 DIN Standards:³

[DIN 1725 Specification for Aluminum Alloys](#)

[DIN 12785 Specifications for Glass Thermometers](#)

¹ This test method is under the jurisdiction of ASTM Committee D02 on Petroleum Products, Liquid Fuels, and Lubricants and is the direct responsibility of Subcommittee D02.06 on Analysis of Liquid Fuels and Lubricants.

Current edition approved ~~May 1, 2020~~ Oct. 1, 2021. Published ~~June 2020~~ October 2021. Originally approved in 1995. Last previous edition approved in ~~2019~~ 2020 as ~~D5800 – 19a~~ D5800 – 20. DOI: ~~10.1520/D5800-20~~ 10.1520/D5800-21.

² For referenced ASTM standards, visit the ASTM website, www.astm.org, or contact ASTM Customer Service at service@astm.org. For *Annual Book of ASTM Standards* volume information, refer to the standard's Document Summary page on the ASTM website.

³ Available from Deutsches Institut für Normung e.V.(DIN), Am DIN-Platz, Burggrafenstrasse 6, 10787 Berlin, Germany, <http://www.din.de>.

*A Summary of Changes section appears at the end of this standard

3. Terminology

3.1 Definitions of Terms Specific to This Standard:

3.1.1 *evaporation loss, n*—of a lubricating oil by the Noack method, that mass of volatile oil vapors lost when the oil is heated in a test crucible through which a constant flow of air is drawn.

3.1.2 *volatility, n*—the tendency of a liquid to form a vapor.

4. Summary of Test Method

4.1 A measured quantity of sample is placed in an evaporation crucible or reaction flask that is then heated to 250 °C with a constant flow of air drawn through it for 60 min. The loss in mass of the oil is determined.

4.2 Interlaboratory tests have shown that Procedure A, Procedure B, Procedure C, and Procedure D yield statistically equivalent precision, with a correlation coefficient of $R^2 = 0.996$ (see research report).

5. Significance and Use

5.1 The evaporation loss is of particular importance in engine lubrication. Where high temperatures occur, portions of an oil can evaporate.

5.2 Evaporation may contribute to oil consumption in an engine and can lead to a change in the properties of an oil.

5.3 Many engine manufacturers specify a maximum allowable evaporation loss.

5.4 Some engine manufacturers, when specifying a maximum allowable evaporation loss, quote this test method along with the specifications.

5.5 The apparatuses used in Procedure C (see [Annex A2](#)) and Procedure D, also permit collection of the volatile oil vapors for determination of their physical and chemical properties. Elemental analysis of the collected volatiles may be helpful in identifying components such as phosphorous, which has been linked to [premature degradation of the emission system catalyst](#).

<https://standards.iteh.ai/catalog/standards/sist/c069caab-af72-41bb-9d37-0d9f1424dc16/astm-d5800-21>

Procedure B—Non-Woods Metal Apparatus

6. Apparatus

6.1 The following procedure, Procedure B, describes an automated test method that uses the same principle, and the same crucible as Procedure A. Only the heat transfer medium to the sample and lid are different. It does not use Woods alloy, and the sample temperature is directly monitored.

6.2 *Noack Evaporative Testers*⁴, (see [Fig. 1](#) and [Fig. 2](#) for both models), comprising the following:

6.2.1 *Heating Block Unit*, electrically heated by base and jacket heaters, having a total power consumption sufficient to ensure a specimen temperature profile similar to the one recorded in the specimen when heated with the Woods metal heater block. In the center of the heating block, there is a circular recess to insert the evaporative crucible. The jacket heater is configured to ensure a direct contact with the crucible. A mechanism is provided to open the jaws for crucible insertion. Two catches on the block prevent the crucible from rising, and the base heater is spring loaded to ensure a direct contact with the crucible.

6.2.2 *Evaporative Crucible*, with screw cover (see [Fig. 3](#)). The crucible is made of stainless steel (see [Fig. 4](#)). Above the support ring is the thread for the cover. The nickel-plated brass cover (see [Fig. 5](#)) is hermetically sealed to the crucible by an internal conical

⁴ The sole source of supply of the apparatus known to the committee at this time for the Model A/B (NCK2/NCK2 5G) is ISL (PAC LP), B.P. 70285 14653 Carpiquet Cedex, Verson, France. If you are aware of alternative suppliers, please provide this information to ASTM International Headquarters. Your comments will receive careful consideration at a meeting of the responsible technical committee,¹ which you may attend.

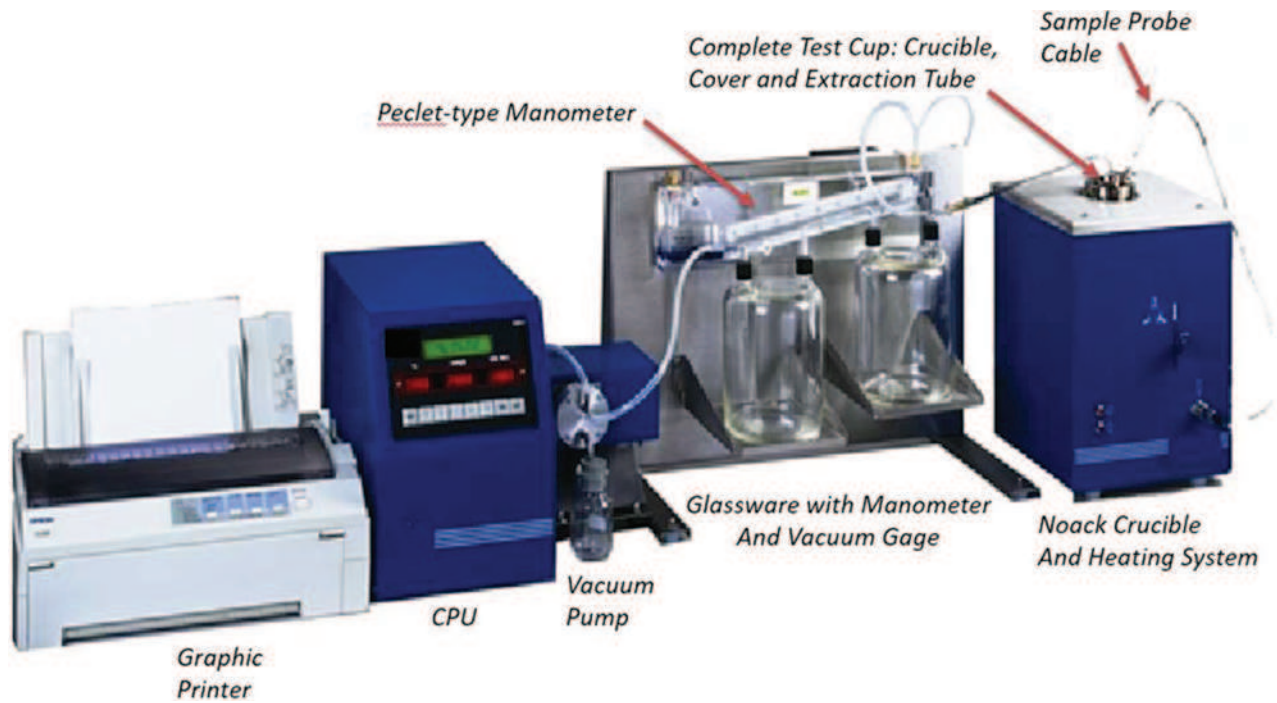

FIG. 1 Model A

iTeh Standards
 (https://standards.itih.ai)
 Document Preview

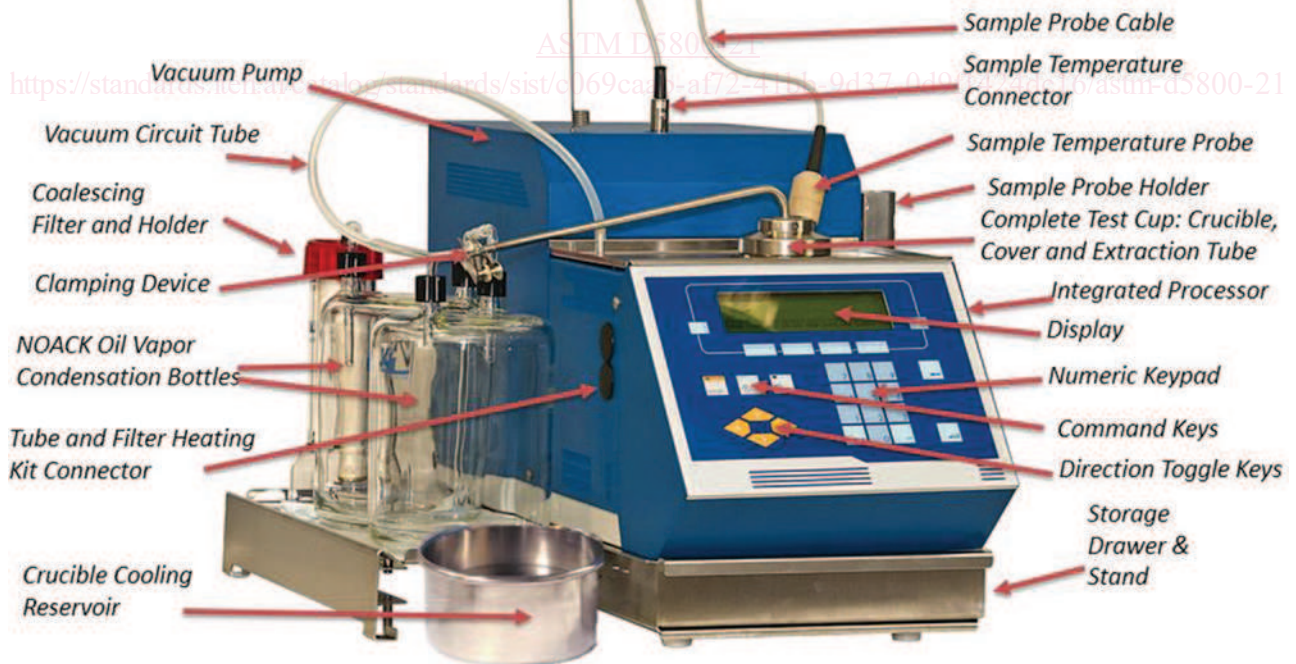

FIG. 2 Model B

sealing surface. Three nozzles of hardened steel (see Fig. 6) permit the air stream to pass through the cover. The extraction tube (see Figs. 7 and 8), which slopes downward, leads from a threaded and sealed connection in the center of the cover.

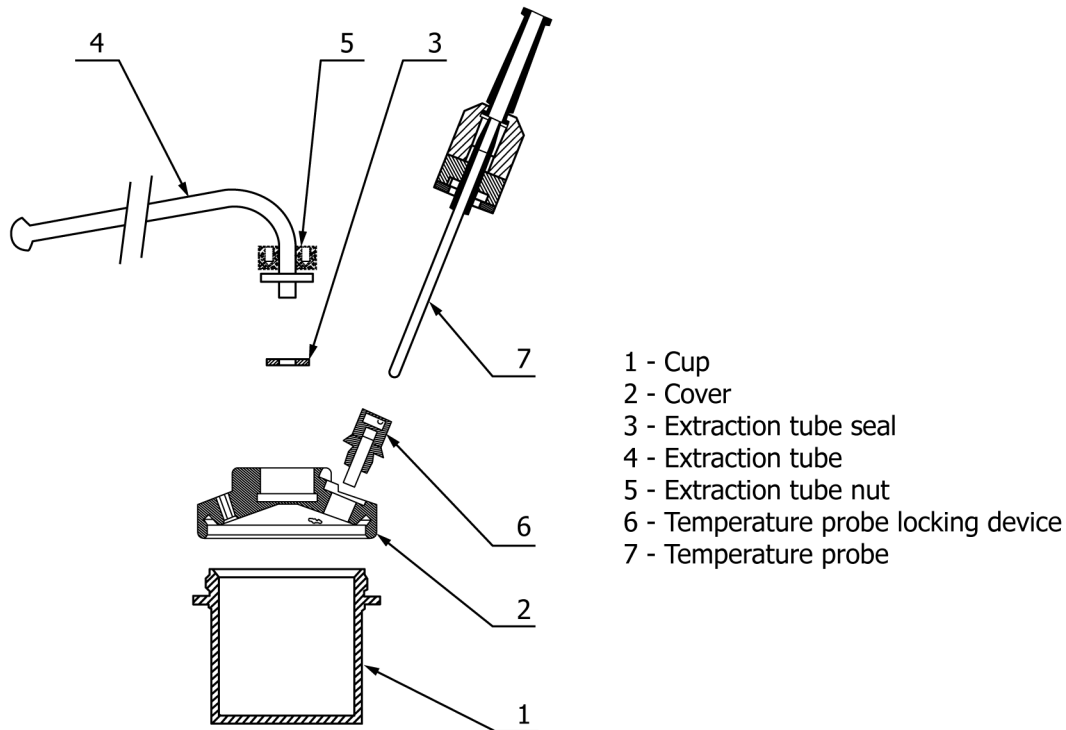

FIG. 3 Crucible with Temperature Probe

6.2.3 *Temperature Probe*—The specimen temperature measuring device shall have an accuracy of 0.5 °C, or better, and a resolution of 0.1 °C, or better. The probe is provided with a calibration certificate of 250.0 °C with a precision of ± 0.1 °C. Its diameter is 4 mm, and its position is as indicated in Fig. 4. It should be calibrated with appropriate procedure at appropriate frequency (minimum once a year).

6.3 *Balance*, capable of weighing at least 500 g to the nearest 0.01 g.

<https://standards.iteh.ai/catalog/standards/sist/c069caab-af72-41bb-9d37-0d9f1424dc16/astm-d5800-21>

6.4 *Crucible Clamp and Spanner*.

6.5 *Reamer*, 2 mm diameter.

6.6 *Ball Bearing*, 3 mm to 5 mm diameter.

6.7 *Glassware Assembly*, strictly identical to the description in A1.1.6 – A1.1.12 and A1.1.15 of Procedure A.

6.8 *Vacuum Pump*.

6.9 *Central Processing Unit (CPU)*, capable of controlling the specimen temperature, the vacuum, the time, the heating, and the printing. The specimen is heated to $245.2 \text{ °C} \pm 0.5 \text{ °C}$ with the temperature profile recorded in the specimen when tested with a Woods metal apparatus (1 h at 250 °C) with automatic test duration compensation. The automatic test duration compensation is used because a test may be started with a heating block at room temperature or at hot temperature when several tests are carried without cooling phase. The CPU automatically adjusts the pressure differential of $20 \text{ mm} \pm 0.2 \text{ mm}$. These conditions can be checked with the printed report.

6.10 *Printer*, to print the graphs of the specimen temperature and the vacuum recorded during the test.

6.11 TMC calibration of the instrument is required for results used in API licensing of formulated automotive engine oils. The calibration procedure is defined in the Lubricant Test Monitoring System (LTMS) document that is maintained by the ASTM Test

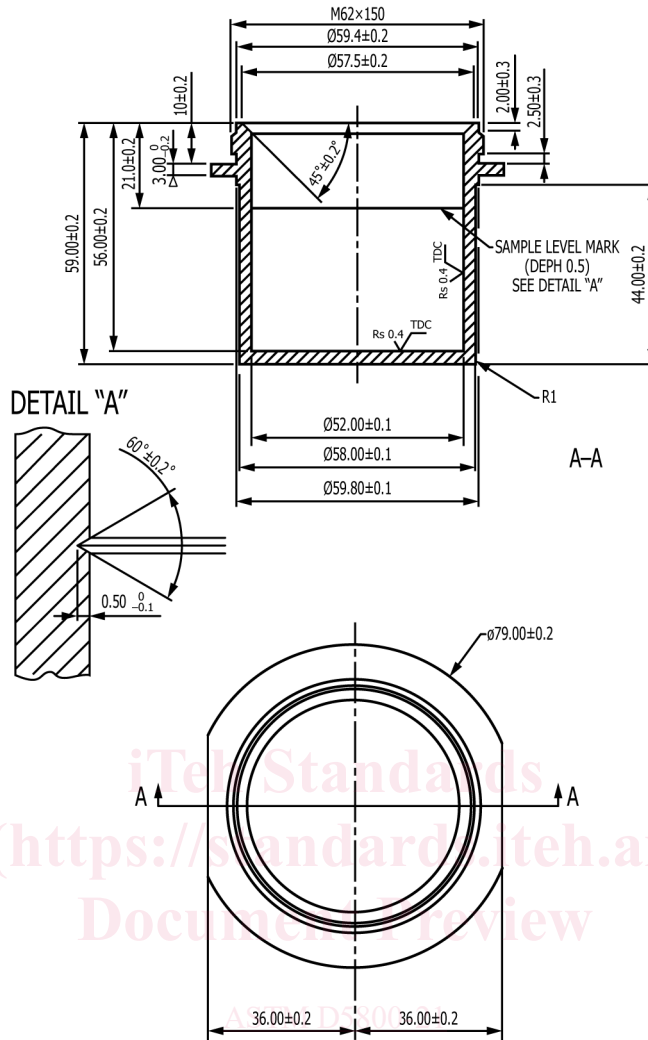

FIG. 4 Noack Cup (Detail 1 of Fig. 3)

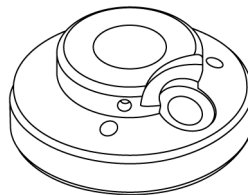

FIG. 5 Crucible Cover (Detail 2 of Fig. 3)

Monitoring Center (TMC)⁵ and is governed by the D02.B0.07 Volatility Surveillance Panel. LTMS severity adjustments shall be applied to results used in API licensing of automotive engine oils (12.2.1).

NOTE 1—It is the perception of the D02.B0.07 Volatility Surveillance Panel that maintaining crucible cup and lid pairings is a measure of good practice which minimizes variability. Under authority of the D02.B0.07 Volatility Surveillance Panel, it has determined that for D5800 Procedure B tests to be considered operationally valid on TMC calibrated instruments, crucible cups and lids are to be initially paired by the testing lab and then remain paired for the entire life-cycle of the crucible set. Moreover, labs may implement and retire paired crucible sets as needed but once initially paired for calibration and candidate product testing, crucible cups and lids must remain paired for all subsequent test runs. Cups and lids shall be engraved or indelibly marked to maintain unique identification. Note that the use of multiple cup-lid pairings does not affect the TMC calibration status of an instrument.

⁵ ASTM Test Monitoring Center, 6555 Penn Avenue, Pittsburgh, PA 15206-4489, <http://www.astmtmc.edu>, <http://www.astmtmc.org>.

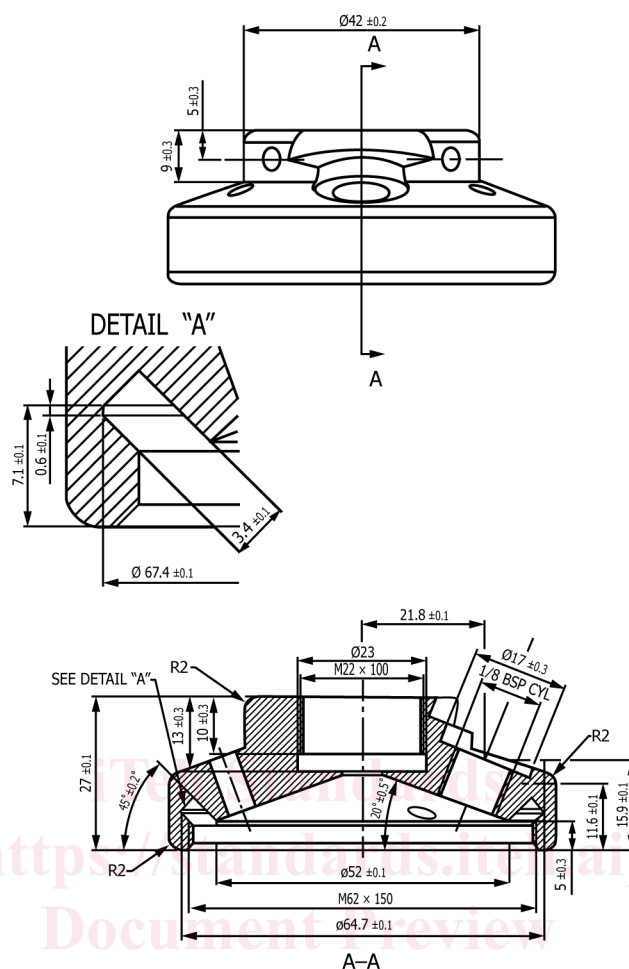

FIG. 5 Crucible Cover (continued)

ASTM D5800-21

7. Reagents and Materials <https://standards.ansi.org/catalog/standards/sist/c069caab-af72-41bb-9d37-0d9f1424dc16/astm-d5800-21>

7.1 *Cleaning Solvent*—A mixture of naphtha and toluene is recommended for cleaning the crucible. (**Warning**—Flammable, vapor harmful.) Overnight soaking may be necessary.

7.2 *Noack Reference Fluid NCO-12 Fluid*—Oil such as NCO-12⁶ having a known evaporative loss for use with all D5800 method procedures. The value of which is provided by the manufacturer.

7.3 *Insulated Gloves.*

7.4 *Drying Paper.*

8. Hazards

8.1 *Safety Hazards*—It is assumed that anyone using this test method will either be fully trained and familiar with all normal laboratory practices, or will be under the direct supervision of such a person. It is the responsibility of the operator to ensure that all local legislative and statutory requirements are met.

NOTE 2—It has been reported during testing high Noack oils using some models that the thermocouple probe can become exposed when evaporation loss

⁶ The sole source of supply of the reference fluid known to the committee at this time is Tannas Co., 4800 James Savage Rd., Midland, MI 48642. If you are aware of alternative suppliers, please provide this information to ASTM International Headquarters. Your comments will receive careful consideration at a meeting of the responsible technical committee,¹ which you may attend.

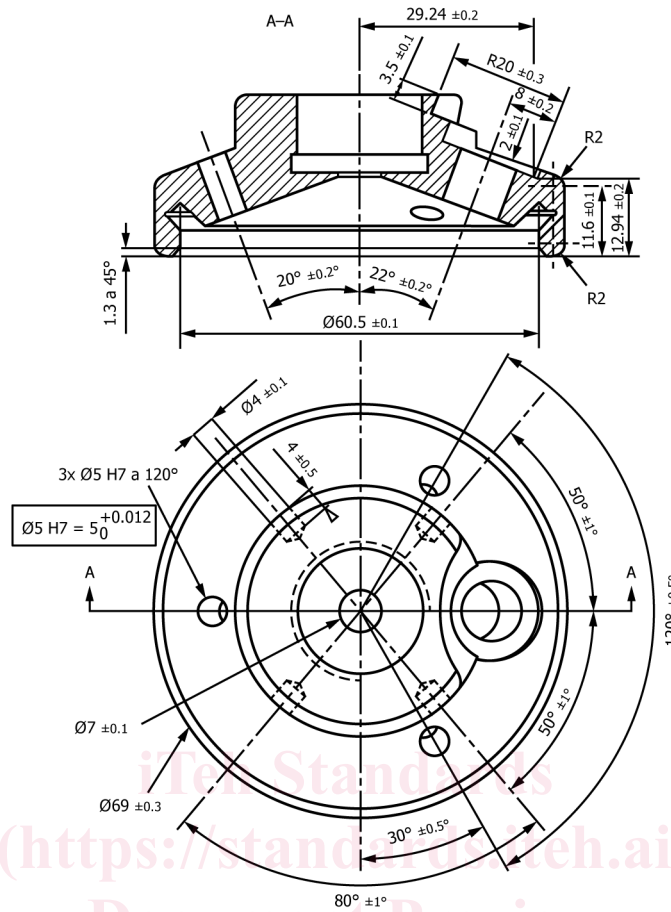

FIG. 5 Crucible Cover (continued)

ASTM D5800-21

is high. While the instrument will alarm to indicate that the temperature fluctuation is greater than allowed in the test method, the heater will not shut off. If not noticed, the oil can continue to heat to close to its flash point, and one laboratory has reported the sample to flash when the probe was removed at the end of the test. Hence, it is suggested to contact the instrument manufacturer to remedy possible malfunction.

8.2 (**Warning**—Though the test method calls for a draft-free area, the exhaust fumes from the evaporating oil must be ventilated to an outside source. Precaution shall be taken to avoid any possibility of fire or explosion.) (See [Note A1.3](#).)

8.3 An alternate means for preventing draft described in [Appendix X3](#) was not used in the development of the test method precision statement.

9. Preparation of Apparatus

9.1 To avoid disturbing the thermal equilibrium, the apparatus shall be assembled in a draft-free area Plexi-glass draft shields are available from the manufacturer, for the model shown in [Fig. 2](#), if drafts in the room cause thermal disturbances (see [Appendix X3](#)).

9.2 Prepare the automated apparatus for operation in accordance with the manufacturer's instructions for calibrating, checking, and operating the equipment.

9.3 Clean the glass bottles, the glass tubing, and the Y-piece to prevent a build-up of condensate.

NOTE 3—Condensate should not be allowed to build up in the 2 L glass bottles. These should be washed out with solvent and dried before a maximum 2 cm of condensate collects.

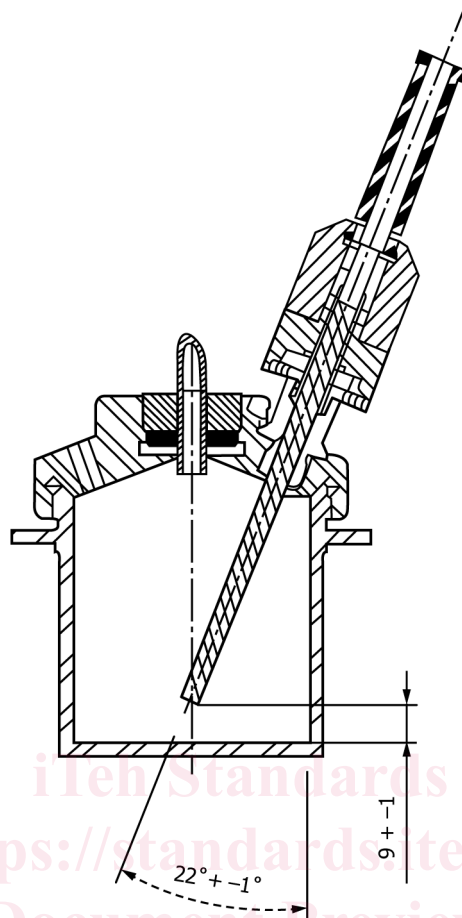

FIG. 6 Specimen Temperature Probe Positioning

ASTM D5800-21

10. Verification standards.iteh.ai/catalog/standards/sist/c069caab-af72-41bb-9d37-0d9f1424dc16/astm-d5800-21

10.1 It is recommended that a Noack reference oil check, such as NCO-12, be run each day of operation. Switch the instrument on a minimum of 30 minutes before running the test to allow temperature stabilization of measurement circuitry

10.2 Make sure that the glassware assembly and the vacuum pump are cleaned and all the connections are sealed.

10.3 Thoroughly clean and dry all parts of the test cup and its accessories before starting the test. Check that the crucible and cover are free from lacquer. Stubborn lacquer should be removed by soaking in the appropriate solvent (see manufacturer’s manual). Pass the reamer through each of the three nozzles in the cover to ensure that they are clear. (**Warning**—Using a reamer with a diameter larger than 2 mm can enlarge the nozzles. This can lead to a wrong losses result due to increased air flow.)

10.4 Run the ball bearing through the extraction tube to ensure that it is clear of contaminants.

10.5 Calibrate the vacuum measuring device in accordance with the manufacturer’s instructions.

10.6 Weigh the empty cup without its cover to the nearest 0.01 g.

10.7 Weigh into the tared crucible $65.0\text{ g} \pm 0.1\text{ g}$ of reference fluid to a precision of 0.01 g. This mass is called M_1 .

10.8 Screw on the cover using the clamp and the spanner. During this phase, make sure that the specimen will never splash on the inside part of the cover. If this occurs, even only one time, the test shall be repeated from 10.3.

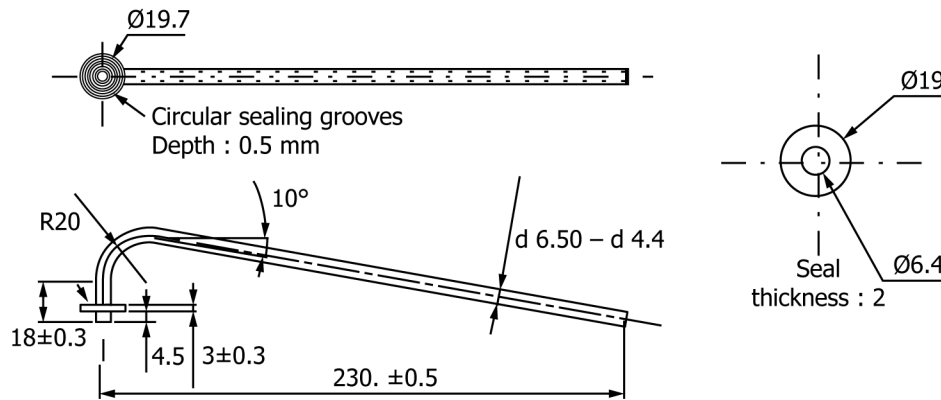

FIG. 7 Extraction Tube (Stainless Steel) with Its Seal (Details 3 and 4 of Fig. 3)

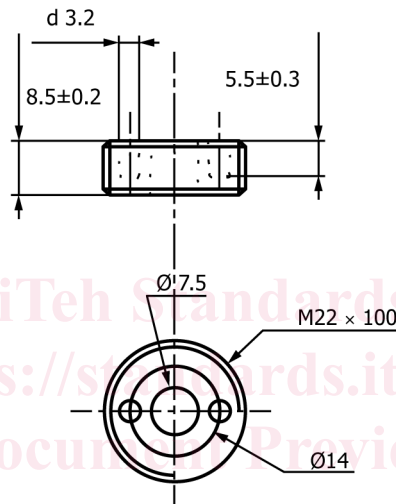

FIG. 8 Extraction Tube Nut (Stainless Steel) (Detail 5 of Fig. 3)

10.9 Connect the specimen temperature probe to the instrument.

10.10 Press down on the locking lever located on the front of the heating block. Place the crucible in the heating block. Rotate the crucible, securing the flange under the screw heads. Adjust the final position of the extraction tube so that it is located in front of the arm of the glass Y-piece, and release the locking lever.

10.11 Connect the extraction tube to the arm of the glass Y-piece, and secure the connection with the clamp. Be sure that the stainless extraction tube, the male connection, and the right arm of the Y-piece are properly aligned.

10.12 Start the test by following manufacturer's instructions. When the audible alarm signals the last 3 minutes of the test, turn off the alarm. Stay in front of the equipment, and be prepared to disconnect the extraction tube.

10.13 After 60 min, the test is automatically stopped, and the end of the test alarm sounds. Remove the specimen temperature probe. Disconnect the extraction tube within 15 s maximum. Press down the locking lever. Remove the crucible. Stop the audible alarm.

10.14 Stand the crucible in a cold DI or distilled water bath to a minimum depth of 30 mm.

10.15 Check the printed report to ensure that the specimen temperature and vacuum plotted curves stayed within the indicated limits. Occasionally the electronics will generate erroneous noise spikes in the graphs. These spikes are evident by a rapid

temperature or pressure excursion followed by a rapid return to baseline conditions. These spikes are not cause for invalidating a test. If however, there are gradual temperature and/or pressure drifts or excessive noise spikes beyond specified limits, perform the necessary system maintenance and/or calibrations. In addition, ensure the apparatus complies with the manufacturer's instruction and that the procedure has been adhered to. After these checks, rerun the test from 10.6.

10.16 After 30 min, remove the crucible from the water bath, dry the outside, and carefully remove the lid. This phase is very critical. Make sure that the sample is never in contact with the inside part of the lid.

NOTE 4—It is very important during the manipulation of the crucible, at the start and the end of the test, to not splash the internal face of the cover with the specimen in the cup. When this occurs, it leads to higher losses and *the test must be rerun*.

10.17 Reweigh the crucible without the lid to the nearest 0.01 g.

10.18 Calculate the M_2 mass by subtracting the empty cup mass from the mass measured in 10.7.

10.19 Calculate to the nearest 0.1 % M/M the evaporation loss of the reference fluid, using the following equation:

$$[(M_1 - M_2)/M_1] \times 100 \quad (1)$$

where:

M_1 = specimen mass before the test, and

M_2 = specimen mass after the test at 245.2 °C.

10.20 Compare the result obtained against the given value for the reference fluid. If the result is within limits, proceed to Section 11.

10.21 If the result is not within the limits, check that the apparatus complies with the manufacturer's instruction and that the procedure has been adhered to.

10.22 Recheck the evaporation loss of the reference oil. To do so, proceed as described in 10.2.

11. Procedure

[ASTM D5800-21](https://standards.iteh.ai/catalog/standards/sist/c069caab-af72-41bb-9d37-0d9f1424dc16/astm-d5800-21)

<https://standards.iteh.ai/catalog/standards/sist/c069caab-af72-41bb-9d37-0d9f1424dc16/astm-d5800-21>

11.1 Weigh into a tared crucible 65 g ± 0.1 g representative of test specimen to a precision of 0.01 g.

NOTE 5—Sample in accordance with Practice D4057 or Practice D4177.

11.2 Proceed as described in 10.3 – 10.17.

11.3 Calculate to the nearest 0.1 % M/M the evaporation loss of the specimen, using Eq 1.

12. Calculation

12.1 Evaporation loss is obtained from the difference in weight before and after test. The specimen is heated in accordance with the temperature profile recorded in the specimen when tested with a Woods metal apparatus (1 h at 250 °C) with automatic test duration compensation. The automatic test duration compensation is used because a test may be started with a heating block at room temperature or at hot temperature when several tests are carried without cooling phase. The checking of these conditions can be done with the printed report. Calculate evaporation loss, using the following equation:

$$[(M_1 - M_2)/M_1] \times 100 \quad (2)$$

where:

M_1 = B – A,

M_2 = C – A,

A = empty crucible weight,

- B* = crucible plus specimen weight, and
C = crucible plus specimen after the test.

12.2 Procedure B and D provide equivalent results (see RR:D02-1887).⁷ Some consistent differences in results determined using Procedures A/C and B/D have been observed depending on the type of sample tested. A test result obtained using one of the procedures can be transformed to an estimated result on the basis of the other procedure as follows:

12.2.1 *Formulated Engine Oils*—The following relationships are based on the round robin test results on formulated engine oils with volatilities in the range of 10.5 % to 21.5 % Noack:

$$\text{Value by Noack Procedure BD} = 1.030 \times \text{Value by Noack Procedure AC} \quad (3)$$

$$\text{Value by Noack Procedure AC} = 0.970 \times \text{Value by Noack Procedure BD} \quad (4)$$

The 95 % confidence limits for the regression coefficient in Eq 3 are 1.021 to 1.033; those for the coefficient in Eq 4 are 0.968 to 0.980.

When results are utilized for API licensing of automotive engine oils, a severity adjustment (SA) shall be applied to the final result of Eq 2. The severity adjustment is determined from the TMC calibration procedure, as stated in 6.11.

12.2.2 The following relationships are based on round robin test results on basestocks with volatilities in the range of 4 % to 25 % Noack:

$$\text{Value by Noack Procedure BD} = 0.962 \times \text{Value by Noack Procedure AC} \quad (5)$$

$$\text{Value by Noack Procedure AC} = 1.039 \times \text{Value by Noack Procedure BD} \quad (6)$$

The 95 % confidence limits for the regression coefficient in Eq 5 are 0.950 to 0.959; those for the coefficient in Eq 6 are 1.043 to 1.053.

NOTE 6—The results of Noack residue should not be rounded up before using the multiplication factors given in Eq 3-6.

13. Report

13.1 Report the following information:

13.1.1 The nearest 0.1 % M/M as evaporation loss (Test Method D5800, Procedure B).

13.1.2 If a severity adjustment is applicable to the result, the non-adjusted value, the severity adjustment, and the severity-adjusted value are to be reported.

13.2 Conversion of values from either D5800 A/C or D5800 B/D to the other:

13.2.1 Only if the nature of the test specimen is known with certainty, in other words, it is known to be either a basestock or a formulated engine oil, the evaporation loss calculated in 12.2.1 on the basis of either Procedure A/C or Procedure B/D may be converted to an equivalent result on the basis of the other procedure. The appropriate equation from those above should be selected and applied according to the type of the sample tested (formulated engine oil or basestock).

13.3 Report the converted result from Procedure A/C to B/D, or Procedure B/D to A/C to the nearest 0.1 m % as evaporation loss of the test sample as converted from the original procedure to the calculated basis procedure.

13.4 If the nature of the test specimen is not known as being either a basestock or a formulated engine oil, the results of the test using Procedure B or D must be identified as being run under Procedure B or D and the value of percent evaporation so obtained will require additional information on the nature of the test specimen for calculations to be made to generate the standard value produced by Procedure A or C.

13.4.1 Converted results should be reported as D5800 A/C (converted from the results obtained by D5800 B/D) or as D5800 B/D (converted from the results obtained by D5800 A/C).

⁷ Supporting data have been filed at ASTM International Headquarters and may be obtained by requesting Research Report RR:D02-1887. Contact ASTM Customer Service at service@astm.org.

14. Precision and Bias⁸

NOTE 7—Noack S2, Procedure D equipment has been shown to be equivalent in two separate studies (see RR:D02-1887).⁷

14.1 To estimate the precision of Procedure B, the test results from the interlaboratory study were analyzed following Practice **D6300**.

14.2 The interlaboratory study included ten oils, three base oils, and seven finished oils, tested in thirty laboratories.

14.3 The precision of this test method, as determined by the statistical examination of the interlaboratory study test results, is as follows:

14.3.1 *Repeatability*—The quantitative expression for the random error associated with the difference between two independent results obtained under repeatability conditions that would be exceeded with an approximate probability of 5 % (one case in 20 in the long run) in the normal and correct operation of the test method:

$$\text{Repeatability} = 0.1331 \cdot X^{0.7443} \quad (7)$$

where:

X = average of the two determinations under consideration.

14.3.2 *Reproducibility*—A quantitative expression for the random error associated with the difference between two independent results obtained under reproducibility conditions that would be exceeded with an approximate probability of 5 % (one case in 20 in the long run) in the normal and correct operation of the test method:

$$\text{Reproducibility} = 0.2411 \cdot X^{0.7443} \quad (8)$$

where:

X = average of the two determinations under consideration.

14.4 *Bias*—Since there is no accepted reference suitable for determining the bias for this procedure, no statement on bias is being made.

[ASTM D5800-21](https://standards.iteh.ai/catalog/standards/sist/c069caab-af72-41bb-9d37-0d9f1424dc16/astm-d5800-21)

<https://standards.iteh.ai/catalog/standards/sist/c069caab-af72-41bb-9d37-0d9f1424dc16/astm-d5800-21>

⁸ Supporting data have been filed at ASTM International Headquarters and may be obtained by requesting Research Report RR:D02-1785. Contact ASTM Customer Service at service@astm.org. As determined by the round robin, no significant difference in results exists between Procedure B and Procedure C.

Procedure D—Automated Non-Woods Metal Noack S2 Volatility Test Apparatus

15. Apparatus⁹

15.1 *Noack S2 (Trademark) Instrument*—Fig. 9, including parts as follows:

15.1.1 *Reaction Vessel and Heater*, capable of heating a sample quickly to test temperatures of 250 °C.

15.1.2 *Teflon Lid Assembly*.

15.1.3 *Coalescing Filter*.

15.1.4 *Pump Filter*.

15.1.5 *Orifice Tube*.

15.1.6 *Magnetic Cross Stir Bar*.

15.1.7 *Thermocouple, PT100*.

15.1.8 *Viton O-rings*.

15.1.9 *Coalescing Filter Cartridges*.

15.1.10 *Pump Filter Cartridges*.

15.2 *Balance*, capable of weighing at least 500 g to the nearest 0.01 g.

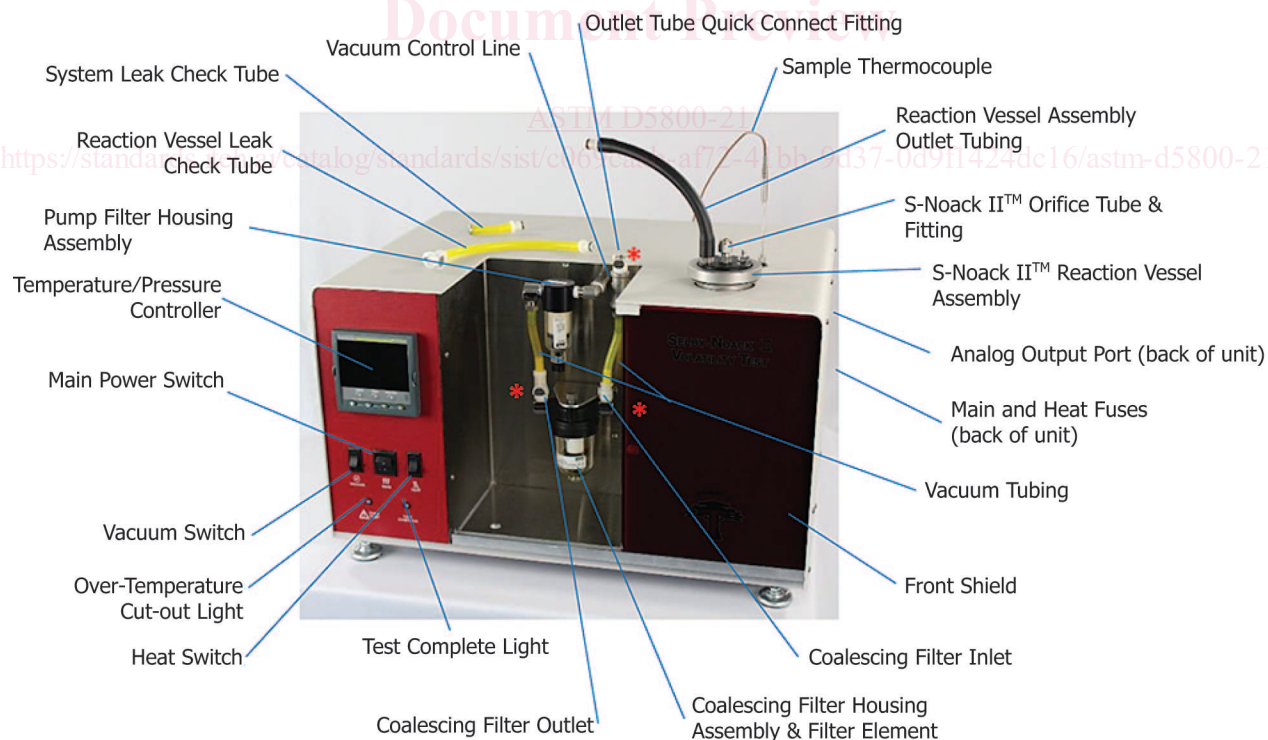

FIG. 9 Noack S2 Test Equipment

⁹ The sole source of supply of the apparatus known to the committee at this time is Tannas Co., 4800 James Savage Rd., Midland, MI 48642. If you are aware of alternative suppliers, please provide this information to ASTM International Headquarters. Your comments will receive careful consideration at a meeting of the responsible technical committee,¹ which you may attend.