



Designation: ~~D2872~~—19 D2872 – 21

Standard Test Method for Effect of Heat and Air on a Moving Film of Asphalt (Rolling Thin-Film Oven Test)¹

This standard is issued under the fixed designation D2872; the number immediately following the designation indicates the year of original adoption or, in the case of revision, the year of last revision. A number in parentheses indicates the year of last reappraisal. A superscript epsilon (ϵ) indicates an editorial change since the last revision or reappraisal.

1. Scope

1.1 This test method is intended to measure the effect of heat and air on a moving film of semi-solid asphaltic materials. The effects of this treatment are determined from measurements of the selected properties of the asphalt before and after the test.

1.2 The values stated in inch-pound units are to be regarded as the standard.

1.3 The text of this standard references notes and footnotes which provide explanatory material. These notes and footnotes (excluding those in tables and figures) shall not be considered as requirements of the standard.

1.4 *This standard does not purport to address all of the safety concerns, if any, associated with its use. It is the responsibility of the user of this standard to establish appropriate safety, health, and environmental practices and determine the applicability of regulatory limitations prior to use.*

1.5 *This international standard was developed in accordance with internationally recognized principles on standardization established in the Decision on Principles for the Development of International Standards, Guides and Recommendations issued by the World Trade Organization Technical Barriers to Trade (TBT) Committee.*

2. Referenced Documents

[ASTM D2872-21](#)

<https://standards.iteh.ai/catalog/standards/sist/083775b9-b93b-44e7-965c-0e7a525936b7/astm-d2872-21>

2.1 *ASTM Standards:*²

[D113 Test Method for Ductility of Asphalt Materials](#)

[D2171/D2171M Test Method for Viscosity of Asphalts by Vacuum Capillary Viscometer](#)

[D3666 Specification for Minimum Requirements for Agencies Testing and Inspecting Road and Paving Materials](#)

[E1 Specification for ASTM Liquid-in-Glass Thermometers](#)

[E77 Test Method for Inspection and Verification of Thermometers](#)

[E220 Test Method for Calibration of Thermocouples By Comparison Techniques](#)

[E644 Test Methods for Testing Industrial Resistance Thermometers](#)

[E1137/E1137M Specification for Industrial Platinum Resistance Thermometers](#)

[E2877 Guide for Digital Contact Thermometers](#)

3. Summary of Test Method

3.1 A moving film of asphaltic material is heated in an oven for 85 min at 325 °F (163 °C). The effects of heat and air are

¹ This test method is under the jurisdiction of ASTM Committee D04 on Road and Paving Materials and is the direct responsibility of Subcommittee D04.46 on Durability and Distillation Tests.

Current edition approved June 15, 2019/Nov. 1, 2021. Published June 2019/November 2021. Originally approved in 1970. Last previous edition approved in 2012/2019 as ~~D2872—12~~:D2872 – 19. DOI: 10.1520/D2872-19;10.1520/D2872-21.

² For referenced ASTM standards, visit the ASTM website, www.astm.org, or contact ASTM Customer Service at service@astm.org. For *Annual Book of ASTM Standards* volume information, refer to the standard's Document Summary page on the ASTM website.

determined from changes in physical test values as measured before and after the oven treatment. An optional procedure is provided for determining the change in sample mass.

3.2 Precision values for this test method have been developed for viscosity at 140 °F (60 °C); ductility at 60 °F (15.6 °C); and mass change.

4. Significance and Use

4.1 This test method indicates approximate change in properties of asphalt during conventional hot-mixing at about 302 °F (150 °C) as indicated by viscosity and other rheological measurements. It yields a residue which approximates the asphalt condition as incorporated in the pavement. If the mixing temperature differs appreciably from the 302 °F (150 °C) level, more or less effect on properties will occur. This test method can also be used to determine mass change, which is a measure of asphalt volatility.

NOTE 1—The quality of results produced by this standard is dependent on the competence of the personnel performing the procedure and the capability, calibration, and maintenance of the equipment used. Agencies that meet the criteria of Specification D3666 are generally considered capable of competent and objective testing, sampling, inspection, etc. Users of this standard are cautioned that compliance with Specification D3666 alone does not completely ensure reliable results. Reliable results depend on many factors; following the suggestions of Specification D3666 or some similar acceptable guidance provides a means of evaluating and controlling some of those factors.

5. Apparatus

5.1 *Oven*—This shall be a double-walled, electrically heated convection-type oven. Its inside dimensions shall be 15 in. (381 mm) high, 19 in. (483 mm) wide (including the plenum), and $17\frac{1}{2} \pm \frac{1}{2}$ in. (445 ± 13 mm) deep (with the door closed). The door shall contain a symmetrically located window with dimensions of 12 to 13 in. (305 to 330 mm) wide by 8 to 9 in. (203 to 229 mm) high. The window shall contain two sheets of heat-resistant glass separated by an air space. The window should permit an unobstructed view of the interior of the oven. The top of the upper heating element shall be $1 \pm \frac{1}{8}$ in. (25 ± 3 mm) below the oven floor.

5.1.1 The oven shall be vented at the top and bottom. The bottom vents shall be located symmetrically to supply incoming air around the heating elements. They shall have an open area of 2.31 ± 0.11 in.² (15.0 ± 0.7 cm²). The top vents shall be symmetrically arranged in the upper part of the oven and have an open area of 1.45 ± 0.07 in.² (9.3 ± 0.45 cm²).

5.1.2 The oven shall have an air plenum covering the side walls and ceiling. The air space shall be $1\frac{1}{2}$ in. (38.1 mm) deep from the walls and ceiling. At a midpoint in the width of the oven, and 6 in. (152.4 mm) from the face of the circular metal carriage to its axis, a squirrel cage-type fan $5\frac{1}{4}$ in. (133 mm) OD by $2\frac{7}{8}$ in. (73 mm) wide shall be turned at 1725 rpm by an externally mounted motor. The squirrel cage fan shall be set so that the fan turns in an opposite direction to its vanes. The air flow characteristics of the fan-plenum system shall be suction from the floor of the oven through the wall plenums and exhaust of the air through the fan. Figs. 1 and 2 show details of this plenum system.

5.1.3 The oven shall be equipped with a proportional control thermostat capable of maintaining a temperature of 325 °F (163 °C) to within ± 1.0 °F (± 0.5 °C). The sensing element of the thermostat may be placed at any location that enables the oven to maintain temperature control as specified by this standard.

5.1.4 The thermometer shall be hung or affixed to a mounting in the ceiling which is 2 in. (50.8 mm) from the right side of the oven at a midpoint in the depth of the oven. The thermometer shall hang down into the oven so that the bulb of the thermometer is within 1 in. of an imaginary line level with the shaft of the circular metal carriage. The heating controls shall be capable of bringing the fully loaded oven back to the test temperature within a 10-min period after insertion of the samples in a preheated oven.

5.1.5 The oven shall be provided with a 12-in. (304.8-mm) diameter, vertical circular carriage (see Fig. 2 for details). This carriage shall be provided with suitable openings and clips for firmly holding eight glass containers in a horizontal position (see Fig. 3). The vertical carriage shall be mechanically driven through a $\frac{3}{4}$ -in. (19-mm) diameter shaft at a speed of 15 ± 0.2 r/min.

5.1.6 The oven shall be equipped with an air jet positioned to blow heated air into each bottle at its lowest point of travel. The air jet shall have an outlet orifice 0.04 in. (1.016 mm) in diameter (No. 60 drill) connected to a 25-ft (7.6-m) length of $\frac{5}{16}$ -in. (8-mm) outside diameter refrigeration copper tubing. This tubing shall be coiled to lie flat on the bottom of the oven and lead to a source of fresh, dried, dust-free regulated air.

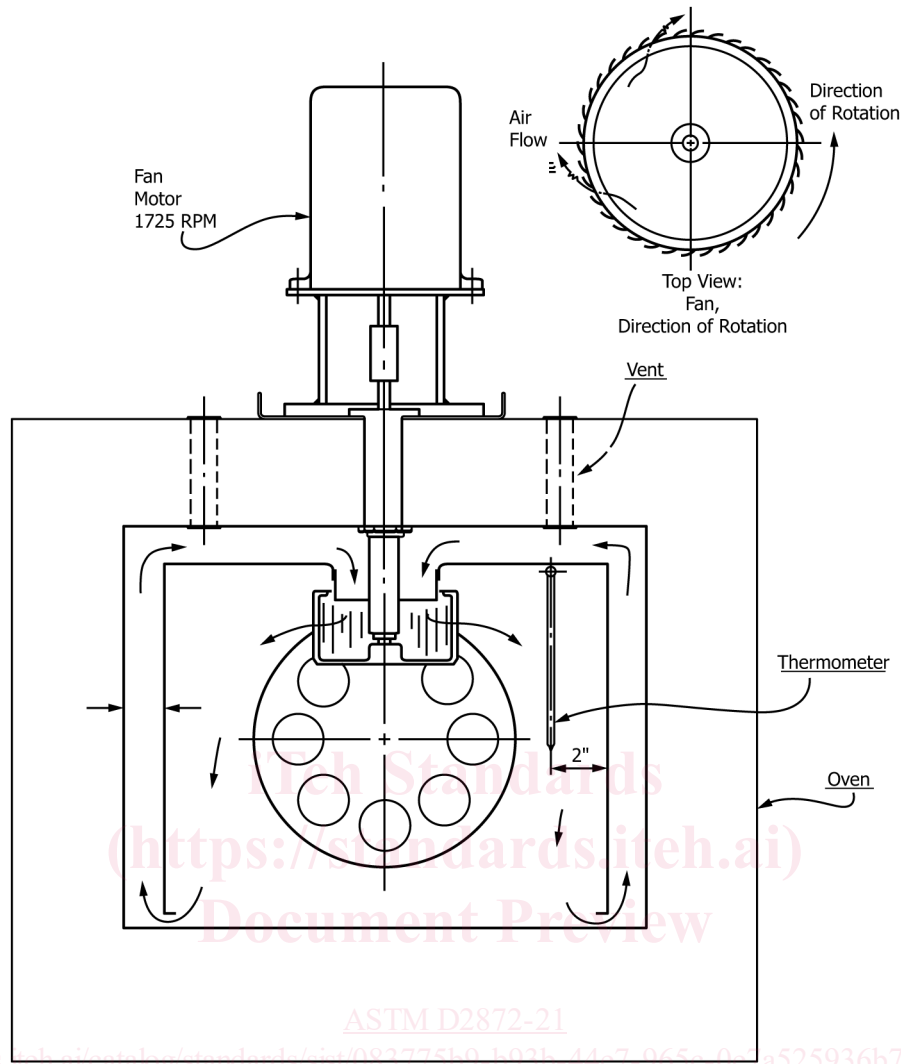

FIG. 1 Schematic of Air Flow Front View

NOTE 2—Activated silica gel treated with an indicator is a satisfactory desiccant for the dried air.

5.2 *Flowmeter—Flow Meter*—The ~~flowmeter~~ flow meter may be any suitable type capable of accurately measuring the airflow at a rate of 4000 mL/min. The ~~flowmeter~~ flow meter shall be located downstream of all regulating devices and upstream of the copper coil. The ~~flowmeter~~ flow meter shall be positioned so it is maintained at approximately room temperature. The airflow shall be calibrated periodically using a wet-test meter or other displacement method. This calibration shall be based on airflow exiting the air jet and shall be conducted with the oven off and at room temperature.

5.3 *Thermometer—Thermometric Device for Oven Standardization*, This shall be an ASTM thermometer conforming to the requirements for Thermometer 13C as prescribed in Specification E1. This thermometer shall be used to make all temperature measurements required by this test method. In order to reduce the risks associated with thermometer breakage, the thermometer may be fully or partially encapsulated in an optically transparent polymer sheath having a maximum thickness of 0.01 in. (0.25 mm). If a sheath is used, it shall be installed such that there is substantial mechanical contact with the thermometer. The thermometer shall be recalibrated after installation of a sheath with suitable range, and is one of the following:

5.3.1 An ASTM Thermometer 13C as prescribed in Specification E1 and calibrated annually in accordance with Test Method E77.

NOTE 3—In order to reduce the risks associated with thermometer breakage, the thermometer may be fully or partially encapsulated in an optically transparent polymer sheath having a maximum thickness of 0.01 in. (0.25 mm). If a sheath is used, it should be installed such that there is substantial mechanical contact with the thermometer.

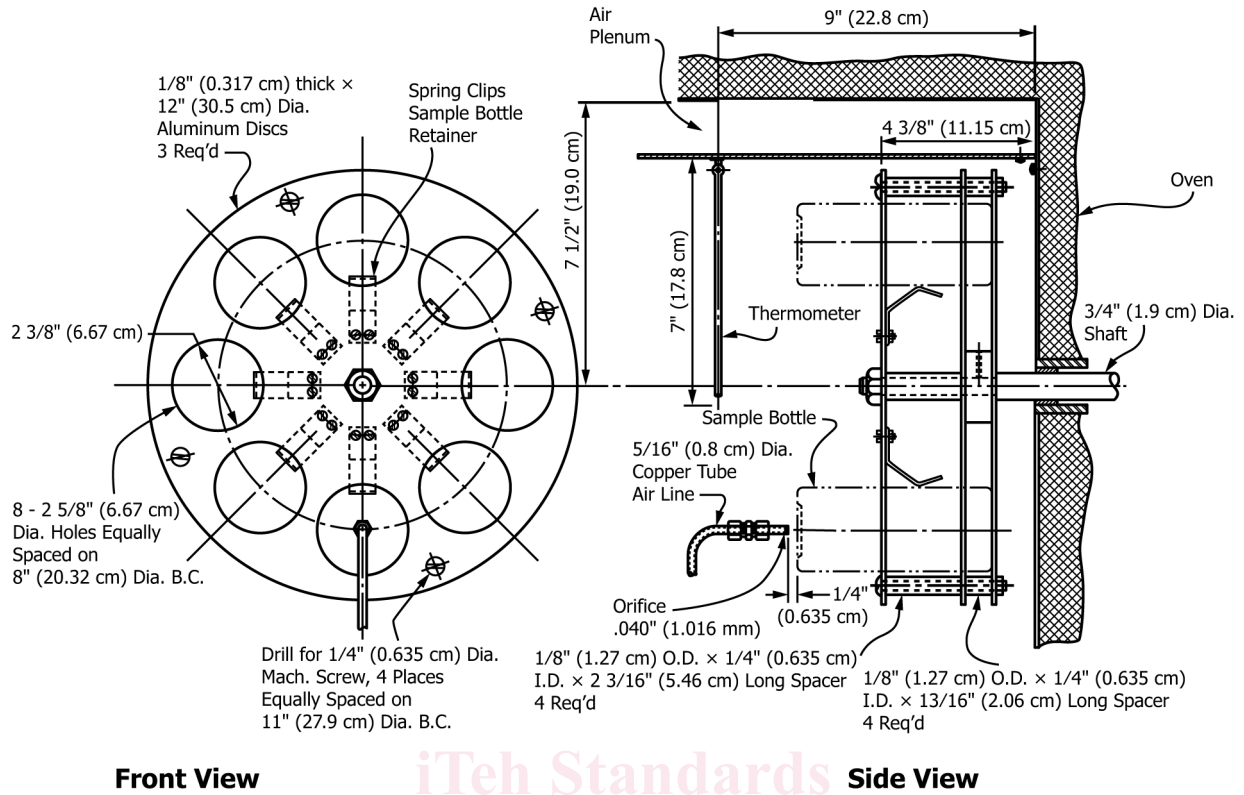

FIG. 2 Circular Metal Carriage

iteh Standards
 (https://standards.iteh.ai)
 Document review

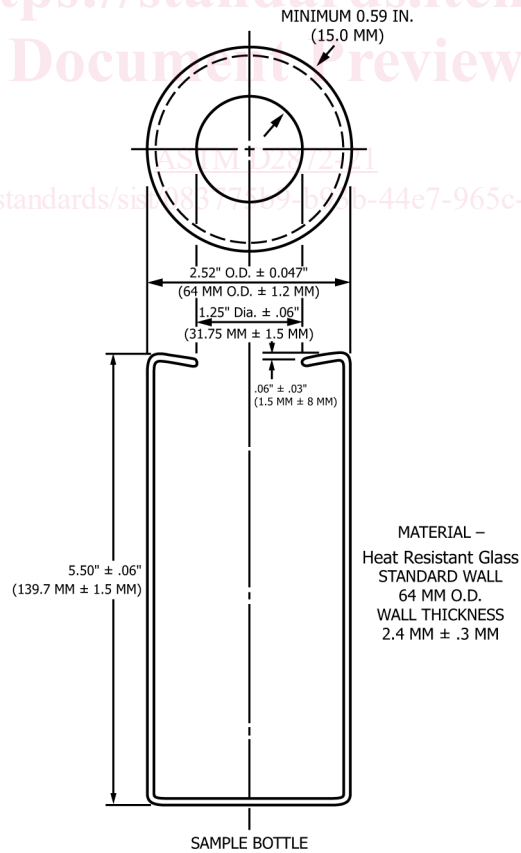

FIG. 3 Sample Bottle

5.3.2 A thermocouple thermometer with accuracy of 0.5 °C, conforming to the requirements in Guide E2877. The thermocouple thermometer shall be calibrated annually as a single unit in accordance with Test Method E220.

5.3.3 A platinum resistance thermometer (PRT) with accuracy of 0.5 °C, conforming to the requirements of Specification E1137/E1137M. The test thermometer may be replaced with an electronic temperature measurement system, provided the following requirements. The PRT system (probe and readout) shall be calibrated annually as a single unit in accordance with Test Methods E644 are met.

~~5.3.1.1 The electronic temperature sensor shall be a three- or four-wire, Grade A platinum resistance thermometer (PRT) substantially conforming to the requirements of Specification E1137/E1137M. The temperature sensor shall be mounted in the same position and orientation as the test thermometer it replaces.~~

~~5.3.1.2 The electronic sensor shall have a thermal response time that differs by no more than 30 % from the thermal response time of the designated test thermometer. Thermal response shall be defined as the time required to achieve a 95 % response to a temperature step change, starting in air at ambient temperature, and ending in air at any convenient and constant temperature in the range of 165 to 170 °C. Guidance for determining thermal response time is given in Test Methods E644.~~

~~5.3.1.3 The electronic measurement circuitry shall include a digital display having a resolution of 0.1 °C or better.~~

~~5.3.1.4 The electronic temperature sensor and electronic measurement circuitry shall be calibrated and verified as a unit. Calibration and verification shall be NIST traceable. The temperature measurement system shall be calibrated prior to being placed into service and verified annually thereafter. Guidance for performing the calibration is given in Test Methods E644.~~

~~5.3.1.5 Verification shall be conducted with the test oven equilibrated at normal operating temperature while the verification sensor is in mechanical contact with the normal test sensor. If the difference between the verification sensor and the normal test sensor exceeds 0.2 °C, the verification will be regarded as having failed, and the temperature measurement system shall be recalibrated.~~

5.4 Thermometric Device for Daily Oven Verification—An equivalent of the devices listed in 5.3.1 or 5.3.2 may be used, however, the calibration requirements are not necessary. These devices shall be standardized annually.

5.4.1 A working thermometric device that is placed in the oven daily or remains in the oven does not need to be calibrated. If a calibrated thermometric device is used in this manner, then it loses its calibration status.

5.5 Container—The container in which the sample is to be tested shall be of clear, transparent, heat-resistant glass conforming to the dimensions shown in Fig. 3.

5.6 Cooling Rack—A wire or sheet metal rack, constructed of stainless steel or aluminum, which allows the sample containers to cool in a horizontal position, with each container in the same horizontal plane. The rack shall be constructed in a way that allows air to flow freely around each container with at least 1 in. (2.5 cm) clearance between containers and at least 1 in. (2.5 cm) clearance between the containers and any solid surface.

6. Determination of Oven Preheat Time

6.1 Determine the preheat time for the oven in accordance with either 6.1.1 or 6.1.2. If 6.1.1 is used, this determination must be made for each oven, and shall be repeated at least annually or whenever environmental conditions or the test location change. If 6.1.2 is used, no annual determination is necessary.

6.1.1 Adjust the oven control thermostat to the setting that will be used during the test. Select this setting so that when the oven is fully loaded and the air is on, the oven will equilibrate at 325 ± 1 °F (163 ± 0.5 °C), as indicated by the test thermometer. Turn the oven on and simultaneously record the start time to the nearest whole minute. Determine and record the temperature of the oven at 15-min intervals. Continue this process until the oven reaches thermal equilibrium. Thermal equilibrium is considered to be the time when the oven temperature does not vary by more than 1 °F (0.5 °C) between two consecutive readings. The oven preheat time is the time that it takes to reach thermal equilibrium plus an additional 30 min.

6.1.2 In lieu of completing the steps described in 6.1.1, a minimum preheat time of 4 h may be used.