



Designation: G181 – 21

Standard Test Method for Conducting Friction Tests of Piston Ring and Cylinder Liner Materials Under Lubricated Conditions¹

This standard is issued under the fixed designation G181; the number immediately following the designation indicates the year of original adoption or, in the case of revision, the year of last revision. A number in parentheses indicates the year of last reapproval. A superscript epsilon (ϵ) indicates an editorial change since the last revision or reapproval.

1. Scope

1.1 This test method covers procedures for conducting laboratory bench-scale friction tests of materials, coatings, and surface treatments intended for use in piston rings and cylinder liners in diesel or spark-ignition engines. The goal of this procedure is to provide a means for preliminary, cost-effective screening or evaluation of candidate ring and liner materials. A reciprocating sliding arrangement is used to simulate the contact that occurs between a piston ring and its mating liner near the top-dead-center position in the cylinder where liquid lubrication is least effective, and most wear is known to occur. Special attention is paid to specimen alignment, running-in, and lubricant condition.

1.2 This test method does not purport to simulate all aspects of a fired engine's operating environment, but is intended to serve as a means for preliminary screening for assessing the frictional characteristics of candidate piston ring and liner material combinations in the presence of fluids that behave as use-conditioned engine oils. Therefore, it is beyond the scope of this test method to describe how one might establish correlations between the described test results and the frictional characteristics of rings and cylinder bore materials for specific engine designs or operating conditions.

1.3 The values stated in SI units are to be regarded as standard. No other units of measurement are included in this standard.

1.4 *This standard does not purport to address all of the safety concerns, if any, associated with its use. It is the responsibility of the user of this standard to establish appropriate safety, health, and environmental practices and determine the applicability of regulatory limitations prior to use.*

1.5 *This international standard was developed in accordance with internationally recognized principles on standardization established in the Decision on Principles for the Development of International Standards, Guides and Recom-*

mendations issued by the World Trade Organization Technical Barriers to Trade (TBT) Committee.

2. Referenced Documents

2.1 *ASTM Standards:*²

D6838 Test Method for Cummins M11 High Soot Test (Withdrawn 2019)³

E177 Practice for Use of the Terms Precision and Bias in ASTM Test Methods

E691 Practice for Conducting an Interlaboratory Study to Determine the Precision of a Test Method

G40 Terminology Relating to Wear and Erosion

3. Terminology

3.1 For definitions, see Terminology **G40**.

3.2 *Definitions of Terms Specific to This Standard:*

3.2.1 *conditioned oil*—a lubricating oil whose viscosity, composition, and other function-related characteristics have been altered by use in an operating engine, such that the oil's effects on friction and wear reflect those characteristic of the long-term, steady-state engine operation.

3.2.2 *conformal contact*—in friction and wear testing, any macro-geometric specimen configuration in which the curvature of one contact surface matches that of the countersurface.

3.2.2.1 *Discussion*—Examples of conformal contact include a flat surface sliding on a flat surface and a ball rotating in a socket that conforms to the shape of the ball. A pair of surfaces may begin a wear or friction test in a non-conformal contact configuration, but develop a conformal contact as a result of wear.

3.2.3 *lubrication regime*—in liquid-lubricated sliding contact, a certain range of friction coefficients that results from a combination of contact geometry, lubricant viscosity characteristics, surface roughness, normal pressure, and the relative speed of the bearing surfaces.

¹ This test method is under the jurisdiction of ASTM Committee **G02** on Wear and Erosion and is the direct responsibility of Subcommittee **G02.50** on Friction.

Current edition approved Nov. 1, 2021. Published November 2021. Originally approved in 2004. Last previous edition approved in 2017 as G181 – 11 (2017). DOI: 10.1520/G0181-21.

² For referenced ASTM standards, visit the ASTM website, www.astm.org, or contact ASTM Customer Service at service@astm.org. For *Annual Book of ASTM Standards* volume information, refer to the standard's Document Summary page on the ASTM website.

³ The last approved version of this historical standard is referenced on www.astm.org.

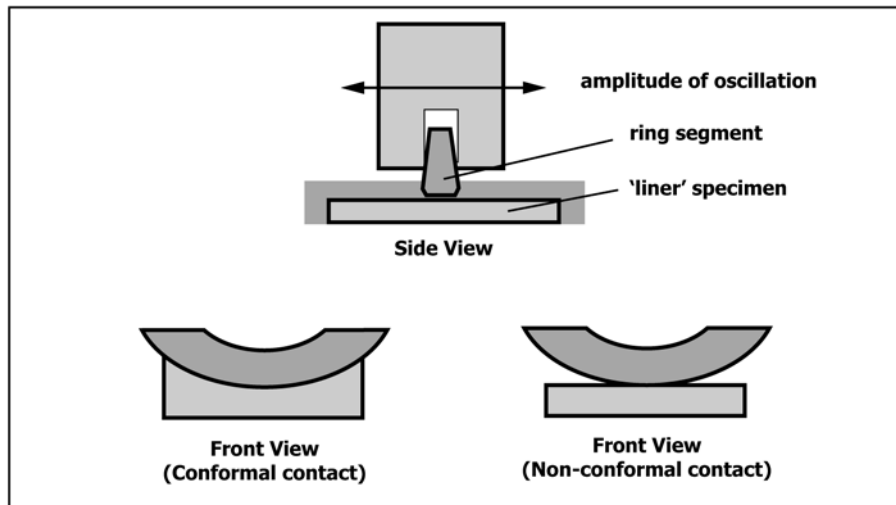

FIG. 1 Schematic Drawing of the Test Configuration Showing Conformal and Non-conformal Contact

3.2.3.1 *Discussion*—Common designations for lubrication regimes are boundary lubrication, mixed film lubrication, elasto-hydrodynamic lubrication and hydrodynamic lubrication.

4. Summary of Test Method

4.1 A reciprocating friction test apparatus is used to simulate the back-and-forth motion of a piston ring within a cylinder bore in the presence of a heated lubricant. Other types of motions, like ring rotation, ring-groove fretting motion, and ring rocking, are not simulated with this procedure. The contact geometry, selection of testing parameters, and the methods of specimen surface finishing and characterization are described. The lubricating fluid is selected to simulate the effects of used oil. A running-in procedure is used to increase the repeatability of results.

5. Significance and Use

5.1 The efficiency and fuel economy of spark ignition and diesel engines is affected in part by the friction between moving parts. Although no reliable, in situ friction measurements exist for fired internal combustion engines, it has been estimated that at least half of the friction losses in such engines are due to those at the ring and liner interface. This test method involves the use of a reciprocating sliding arrangement to simulate the type of oscillating contact that occurs between a piston ring and its mating cylinder bore surface near the top-dead-center position in the cylinder where most severe surface contact conditions occur. There are many types of engines and engine operating environments; therefore, to allow the user the flexibility to tailor this test to conditions representative of various engines, this standard test method allows flexibility in selecting test loads, speeds, lubricants, and durations of testing. Variables that can be adjusted in this procedure include: normal force, speed of oscillation, stroke length, duration of testing, temperature of testing, method of specimen surface preparation, and the materials and lubricants to be evaluated. Guidance is provided here on the set-up of the test, the manner of specimen fixturing and alignment, the selection

of a lubricant to simulate conditioned oil characteristics (for a diesel engine), and the means to run-in the ring specimens to minimize variability in test results.

5.2 Engine oil spends the majority of its operating lifetime in a state that is representative of use-conditioned oil. That is, fresh oil is changed by exposure to the heat, chemical environment, and confinement in lubricated contact. It ages, changing viscosity, atomic weight, solids content, acidity, and chemistry. Conducting piston ring and cylinder liner material evaluations in fresh, non-conditioned oil is therefore unrealistic for material screening. But additive-depleted, used oil can result in high wear and corrosive attack of engine parts. The current test is intended for use with lubricants that simulate tribological behavior after in-service oil conditioning, but preceding the point of severe engine damage.

6. Reagents

6.1 *Cleaning Solvents*—Suitable solvents may be used to degrease and clean specimens prior to conducting the described procedure. No specific solvents are recommended here, except that they should not chemically attack the test surfaces, nor leave a residual film or stain after cleaning.

6.2 *Lubricants*—Lubricants shall be handled appropriately with awareness of, and precautions taken against, any hazards indicated in the Material Safety Data Sheets for those lubricants. A description of engine-conditioned oil is given in [Appendix X2](#).

7. Apparatus and Specimen Preparation

7.1 *Description of the Test Apparatus*—A schematic representation of the reciprocating contact geometry is shown in [Fig. 1](#). Two versions of this test are shown. In the first case ([Fig. 1](#), bottom left), the lower specimen conforms to the shape of the ring segment. In the second case ([Fig. 1](#), bottom right), the ring segment slides on a flat lower specimen. Specimens are placed in a heated, temperature-controlled bath of lubricant. Alternate means of supplying the lubricant, such as drip feed, may be used.

7.1.1 *Motion*—The test apparatus shall be capable of imparting a back-and-forth (herein called reciprocating) motion of constant stroke length and repeatable velocity profile to the simulated piston ring specimen which slides against the simulated cylinder bore under a controlled normal force. The motor shall be sufficiently powered so that the velocity profile and constancy of operation shall be unaffected by the friction force developed between the test specimens. The velocity versus time response of crank-driven devices tends to be approximately sinusoidal, and this type of motion is appropriate to simulate a piston driven by a crankshaft. The frequency of reciprocation, given in cycles per second, shall be selected to induce the appropriate lubrication regime experienced by the piston ring during its slow down and reversal of direction in the engine of interest. Typical frequencies for slider-crank testing equipment of this type range between 5 and 40 cycles per second. The average sliding speed for each stroke, s , in metres per second, is calculated as follows:

$$s = 2fL \quad (1)$$

where:

f = frequency of reciprocation in cycles per second, and
 L = stroke length in meters.

7.1.2 *Stroke Length Selection*—It is unnecessary to set the stroke length equal to the full stroke of the piston in the engine because the greatest frictional influence of the materials is experienced at the ends of the ring travel where operation in the boundary lubrication regime increases the likelihood that contact will occur between the surfaces of the ring and cylinder materials. The stroke length should typically range between 5 and 10 times the width of the worn-in contact face of the piston ring specimen.

NOTE 1—The design of certain testing machines and motor drive systems limits the maximum frequency achievable for a given stroke length. Therefore, a compromise may be necessary between the highest desired stroke length and the desired reciprocating frequency.

7.1.3 *Specimen Fixturing*—A means shall be provided to clamp the ring specimen to the reciprocating portion of the machine in such a way as to ensure correct alignment during sliding. Likewise, the cylinder bore specimen shall be mounted in a suitable, heated lubricant container such that no loosening or other misalignment occurs during the test. For ring segments with a rectangular cross-section, a suitable flat-faced ring-segment grip may be used. For non parallel-sided piston rings (for example, those with keystone-like cross-sections), it may be necessary to prepare a holder from an actual piston or design a holder that clamps the inclined sides of the ring firmly.

7.1.4 *Specimen Alignment*—Proper alignment and centering between sliding surfaces is a critical factor for ensuring repeatable friction test results. Alignment affects the distribution of normal forces on the contact surface as well as the lubrication regimes that change as the ring specimen moves back and forth. Two approaches are used together to ensure proper alignment: (1) mechanical alignment of the test fixtures during the initial test set-up, and (2) running-in of the ring specimen against the counterface surface. The former approach addresses macro-contact aspects of alignment and the latter

micro-scale aspects of alignment. A method for running in specimens is given in [Appendix X1](#).

NOTE 2—Mechanical specimen alignment tends to be difficult to achieve with conformal starting geometry. When testing ring and cylinder materials from the same type of engine, the ring curvature in the actual engine is produced by elastically confining the ring in its groove. The same ring, out of the engine, will tend to have a larger curvature, and hence rest on the edges of the corresponding cylinder bore specimen unless the ring can be pre-stressed or in some other way forced into a radius of curvature that precisely matches that of the opposing specimen cut from the cylinder. A non-conformal, ring-on-flat geometry with a suitable running-in procedure, has been shown to produce a more repeatable worn-in condition for friction testing.

7.1.5 *Normal Force Application*—The apparatus shall have the ability to apply a controlled normal force to the ring and cylinder specimens. The loading mechanism can be a dead-weight system, a levered type of device, or a hydraulic or electromagnetic actuator. The loading system shall have sufficient rigidity and damping capacity to avoid excessive deflections or vibrations during testing, and to maintain the desired normal force within 2 % of the intended value.

7.2 *Specimen Preparation*—Test specimens are herein referred to as the *ring specimen* and the *cylinder bore specimen*. The precise manner of preparing test specimens depends in part on the kinds of materials, coatings, or surface treatments to be evaluated.

7.2.1 *Ring Specimen*—The ring specimen shall be prepared by cutting a segment from a production piston ring, or machining a test piece of equal dimensions and finish to a production piston ring. The ring specimen may be used in its original, factory-finished condition or it may be altered by applying a coating or surface treatment. The surface shall be prepared to simulate that for a particular engine or class of engines. The surface roughness of the ring specimen, in the area of the contact, shall be measured by a suitable method and included in the test record. All pertinent descriptors (type of profiling method, surface finish parameters, and measuring conditions) shall be reported.

7.2.2 *Cylinder Bore Specimen*—The specimen intended to simulate the cylinder bore surface shall constitute either a cut section of a production-finished cylinder or a flat specimen whose form and finish is similar to that of the cylinders used in the engine of interest. Methods have been developed to simulate the roughness and lay of production cylinder liners on flat cast iron test coupons.⁴ Alternatively, a polished surface may be used to simulate the worn condition of a cylinder bore near at the top-dead-center position. In certain cases, the cylinder bore specimen may be fabricated from experimental materials, coated, or surface-treated. The surface roughness of the cylinder bore specimen shall be measured by a suitable method and included in the test record. With stylus-type instruments, it is traditional to measure and report the surface roughness profile parallel to the direction of motion of the ring, that is, parallel to the cylinder axis. All pertinent descriptors

⁴ Blau, P. J., “Simulation of Cylinder Bore Surface Finish Parameters to Improve Laboratory-Scale Friction Tests in New and Used Oil,” *Engine Systems: Lubricants, Components, Exhaust and Boosting System, Design and Simulation*, Amer. Soc. of Mech. Engr., New York, ASME ICE Vol. 37-3, 2001, pp. 57-63.

(type of profiling method, surface finish parameters, and measuring conditions) shall be reported.

7.3 Lubricant Selection—The lubricant should be in a condition that is representative of that found in the engine of interest after a period of running. Studies of experimental piston ring and liner materials have shown that fresh engine lubricants do not in general produce friction and wear test results equal to those obtained with used engine oils under otherwise similar testing conditions.⁵ A guide to formulating fluids with characteristics similar to those of used diesel engine oil is given in [Appendix X2](#).

7.4 Friction Force Measurement and Calibration:

7.4.1 Friction Force Measurement and Recording—A means shall be provided for measuring and recording the magnitude of the friction force. This can involve a tension/compression load cell, strain gauged beam, piezoelectric force sensor, or similar. The friction force sensor should be as close to the line of action of the friction force at the contact point as practical on the test apparatus. The sampling rate should be at least 10 readings per stroke in each direction. Thus, a sampling rate of at least 200 readings per second would be required with a frequency of 10 Hz (10 cycles per second having 1 forward and 1 reverse stroke per cycle). The sign of the friction force is positive when it opposes the direction of relative motion; therefore, the friction data should be corrected to account for the reversal of direction during reciprocating sliding. Data collected during the period of direction reversal should be discarded. The quotient of the instantaneous friction force divided by the normal force is defined as the kinetic friction coefficient.

7.4.2 Calibration—Since mechanical assembly stresses and asymmetry can exist in the design of friction testing apparatus, the friction force shall be calibrated in both directions of reciprocating sliding using a pulley system or similar method for applying a known weight in line with the sliding contact and parallel to the friction force that occurs during testing. The calibration weights shall be chosen to cover the full range of friction forces typically experienced during the testing.

8. Procedure

8.1 Turn on the testing machine and recording equipment and allow the electronics to stabilize for 30 min.

8.2 Measure the surface finish of the ring and liner specimens. This shall include at least the arithmetic average roughness of the liner profiled parallel to the direction of reciprocating motion.

8.3 Mount the ring and liner specimens in the testing machine. Verify proper specimen alignment.

8.4 Conduct a running-in procedure to ensure proper fitting of the ring and liner specimen. (See [Appendix X1](#) for a description of the recommended running-in procedure.)

8.5 Lubrication Methods—Several methods are possible, depending on the objective of the test and the type of

simulation desired. (See [Appendix X2](#) for a description of lubricant preparation to simulate engine-conditioned oil.)

8.5.1 Fully-flooded—Fill the lubricant bath to cover the contact surface with at least 2 mm of the selected lubricant.

8.5.2 Drip-feed Lubrication—A metered drop of lubricant is introduced into the contact periodically, in accordance with an established flow rate or delivery schedule.

8.5.3 Starved Lubrication—A specific quantity of lubricant is placed on the surface before the test is started and no additional lubricant is added for the duration of the test.

8.6 Lubricant Heating—For fully-flooded tests, with no normal load applied, slowly oscillate the upper specimen while the bath heats to the desired temperature. After the test temperature is reached, allow the temperature to equilibrate for 10 min (± 2 °C), then stop the motor. For drip-feed tests or starved lubrication tests, ensure the specimens and lubricant are at the correct test temperature before proceeding.

8.7 Adjust the speed setting to the desired reciprocation frequency, raise the load to the desired test load.

8.8 Run the test for the desired period of time, while monitoring and recording friction force. When running a step loaded test, increase the load to the next level and run for the desired period of time. Repeat the step loading sequence as needed to reach the maximum desired load.

8.9 After completing the test allow specimens to cool with the load removed.

8.10 Remove the test specimens and inspect both contact surfaces. Record observations of ring or bore specimen surface damage, including the dimensions of the wearing contact area on the ring.

9. Report

9.1 Materials—Provide a description of the composition, heat treatment, surface coating, or other identifying designations, or a combination thereof, for the test materials. Indicate the dimensions of the ring segment, particularly the contact width (mm). Describe the surface finish of the liner and ring, including the arithmetic average surface roughness of the liner specimen taken parallel to the direction of ring motion. Additional measures of roughness may also be used. Identify the type and make of apparatus, and stylus radius if applicable, that is used to measure surface roughness. Optional characterization may include the hardness of the ring and liner specimen surfaces.

9.2 Running-in Procedure—Describe the procedure used to run in the ring specimen prior to testing. This should include the sequence of loads and speeds such as those described in the example in [Appendix X1](#).

9.3 Lubrication—Report the type or grade, source, and viscosity of the oil, as well as the method used to prepare the oil to simulate an engine-conditioned lubricant, or the engine duty cycle if using engine-conditioned oil. Describe the method used to apply the lubricant during testing.

9.4 Applied Test Parameters—Report the stroke length (mm), frequency of oscillation (cycles/s), applied load (N), and test duration (h:min:s). If step loading, describe the times and

⁵ Naylor, M. G. S., "Development of Wear-Resistant Ceramic Coatings for Diesel Engine Components," Vol 1, Oak Ridge National Laboratory, Oak Ridge, TN, Report ORNL/Sub/87-SA581/1, 1992, pp. 195.

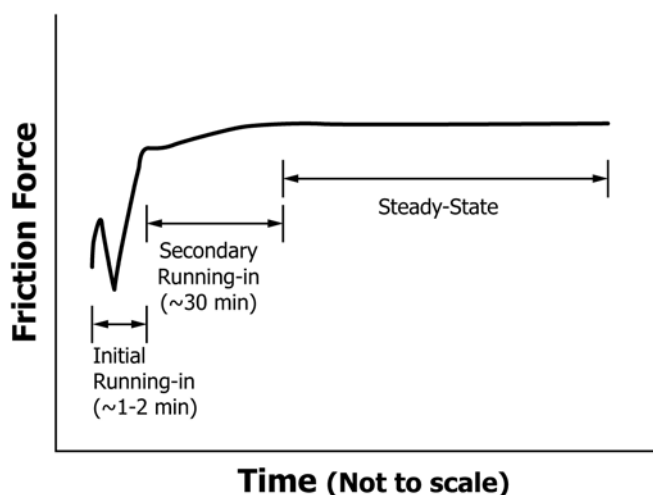

FIG. 2 Typical (not to scale) Friction Force Trace for Constant Applied Load Showing Approximate Time to Reach Steady State

loading sequence applied. Test duration may also be reported in terms of cumulative sliding distance. Also report the test temperature and its typical variation ($\text{deg C} \pm \text{deg C}$).

9.5 Data—Report the time required for the friction force to reach a relatively stable value (running-in period). Report the time-averaged (at least 60 s sampling interval), post running-in friction coefficient. Report the average friction coefficient (at least 60 s sampling interval) at the mid-point of the test and then at the end of the test. A typical friction force trace for a constant applied load is shown schematically in Fig. 2 including the approximate time to reach steady-state conditions.

9.6 Observations—Report the occurrence of any unusual sounds or vibrations. Report the appearance of the ring and liner specimens after testing and cleaning. Observe the condition of the lubricant, and report any changes from the initial condition. Additional lubricant analysis or specimen characterization, such as change in roughness, photographs, or the like, may be included.

9.7 Reporting Form—A sample reporting form is shown in Fig. 3.

10. Precision and Bias⁶

10.1 The precision of this test method is based on an interlaboratory study of Test Method G181 conducted in 2009. Five laboratories reported replicate results, obtained using two different lubricating oils, at normal forces between 20 and 200. Every test result reported represents an individual determination. Except for the use of data from only five laboratories,

⁶ Supporting data have been filed at ASTM International Headquarters and may be obtained by requesting Research Report RR:G02-1013.

Practice E691 was followed for the design and analysis of the data; the details are given in ASTM Research Report RR:G02-1013.⁶

10.1.1 *Repeatability Limit (r)*—Two test results obtained within one laboratory shall be judged not equivalent if they differ by more than the “r” value for that material; “r” is the interval representing the critical difference between two test results for the same material, obtained by the same operator using the same equipment on the same day in the same laboratory. Repeatability limits are listed in Tables 1-10.

10.1.2 *Reproducibility Limit (R)*—Two test results shall be judged not equivalent if they differ by more than the “R” value for that material; “R” is the interval representing the critical difference between two test results for the same material, obtained by different operators using different equipment in different laboratories. Reproducibility limits are listed in Tables 1-10.

10.1.3 The above terms (repeatability limit and reproducibility limit) are used as specified in Practice E177.

10.1.4 Any judgment in accordance with 10.1.1 would normally have an approximate 95 % probability of being correct, however the precision statistics for the analysis obtained in this ILS must not be treated as exact mathematical quantities which are applicable to all circumstances and uses. The limited number of results reported guarantees that there will be times when differences greater than predicted by the ILS results will arise, sometimes with considerably greater or smaller frequency than the 95 % probability limit would imply. Consider the repeatability limit as a general guide, and the associated probability of 95% as only a rough indicator of what can be expected.

10.2 *Bias*—At the time of the study, there was no accepted reference material suitable for determining the bias for this test method, therefore no statement on bias is being made.

10.3 This precision statement was determined through the statistical examination of 300 results from five laboratories, on specimens lubricated with two different types of oil. These oils were described as:

10.3.1 *Oil A*—is a fully-formulated commercial grade 15W40 diesel oil. It was tested in the fresh, unused condition.

10.3.2 *Oil B*—is a fully-formulated diesel oil that was drained from an engine after having run 252 h in the standard Mack T-11 engine test at Southwest Research Institute in October through November 2008. Further information about this type of test may be found in an SAE paper.⁷

11. Keywords

11.1 cylinder liner; diesel oil; friction; liquid lubricant; piston ring

⁷ Shank, G., Goshorn, K., Cooper, M., van Dam, W., and Richards, S., “A History of Mack Engine Lubricant Tests from 1985-2005: Mack T-7 through Mack T-12.” SAE Paper Number 2005-01-3713, SAE International, Warrendale, PA. DOI: 10.4271/2005-01-3713.

**ASTM Standard Practice G XXXX – Data Form
FRICTION OF PISTON RING AND LINER MATERIALS**

Test Number:		Date of Test:	
Operator's name:		Machine used:	

1.0 Materials

	Ring Segment	Liner Specimen
Specimen designation		
Material and source		
Material or surface preparation		
Initial roughness and direction of measurement*		
Specimen dimensions (mm)	contact width _____ contact length _____ ring thickness _____	length _____ width _____ thickness _____

* Roughness measuring method: _____

2.0 Running in Procedure:

3.0 Description of lubricant, method of application and special conditioning:

4.0 Test Conditions:

Applied load(s) (N):		Stroke length (mm):	
Frequency (c/s):		Test (step) duration (s):	
Oil temperature (C):		Other:	

5.0 Test Data

Time to reach steady-state friction force (s):	
Average and range in steady-state friction coefficient (1):*	Load: FC:
(2):*	Load: FC:
(3):*	Load: FC:
Filename or data storage location (if applicable):	

* If step-testing, record results for each step (continue on next page for additional loading steps)

6.0 Observations:

(continued on following page(s) if necessary)

FIG. 3 Example of a Friction Test Data Reporting Form

TABLE 1 Friction Coefficient Data (Normal Force = 20 Newtons)

Material	Average, ^A \bar{x}	Repeatability Standard Deviation, S_r	Coefficient of Variation, CV S_r	Reproducibility Standard Deviation, S_R	Coefficient of Variation, CV S_R	Repeatability Limit, r	Reproducibility Limit, R
Oil A	0.110	0.019	0.173	0.022	0.200	0.054	0.061
Oil B	0.100	0.011	0.110	0.024	0.240	0.030	0.067

^A The average of the laboratories' calculated averages.

TABLE 2 Friction Coefficient Data (Normal Force = 40 Newtons)

Material	Average, ^A \bar{x}	Repeatability Standard Deviation, S_r	Coefficient of Variation, CV S_r	Reproducibility Standard Deviation, S_R	Coefficient of Variation, CV S_R	Repeatability Limit, r	Reproducibility Limit, R
Oil A	0.111	0.015	0.135	0.016	0.144	0.042	0.046
Oil B	0.095	0.011	0.116	0.021	0.221	0.032	0.060

^A The average of the laboratories' calculated averages.

TABLE 3 Friction Coefficient Data (Normal Force = 60 Newtons)

Material	Average, ^A \bar{x}	Repeatability Standard Deviation, S_r	Coefficient of Variation, CV S_r	Reproducibility Standard Deviation, S_R	Coefficient of Variation, CV S_R	Repeatability Limit, r	Reproducibility Limit, R
Oil A	0.115	0.009	0.078	0.010	0.087	0.025	0.028
Oil B	0.093	0.012	0.129	0.021	0.226	0.034	0.060

^A The average of the laboratories' calculated averages.

TABLE 4 Friction Coefficient Data (Normal Force = 80 Newtons)

Material	Average, ^A \bar{x}	Repeatability Standard Deviation, S_r	Coefficient of Variation, CV S_r	Reproducibility Standard Deviation, S_R	Coefficient of Variation, CV S_R	Repeatability Limit, r	Reproducibility Limit, R
Oil A	0.117	0.007	0.060	0.007	0.060	0.019	0.021
Oil B	0.094	0.012	0.128	0.021	0.223	0.034	0.059

^A The average of the laboratories' calculated averages.

TABLE 5 Friction Coefficient Data (Normal Force = 100 Newtons)

Material	Average, ^A \bar{x}	Repeatability Standard Deviation, S_r	Coefficient of Variation, CV S_r	Reproducibility Standard Deviation, S_R	Coefficient of Variation, CV S_R	Repeatability Limit, r	Reproducibility Limit, R
Oil A	0.118	0.006	0.051	0.007	0.059	0.017	0.020
Oil B	0.096	0.012	0.125	0.020	0.208	0.034	0.058

^A The average of the laboratories' calculated averages.

TABLE 6 Friction Coefficient Data (Normal Force = 120 Newtons)

Material	Average, ^A \bar{x}	Repeatability Standard Deviation, S_r	Coefficient of Variation, CV S_r	Reproducibility Standard Deviation, S_R	Coefficient of Variation, CV S_R	Repeatability Limit, r	Reproducibility Limit, R
Oil A	0.120	0.006	0.050	0.008	0.067	0.016	0.021
Oil B	0.100	0.012	0.120	0.020	0.200	0.033	0.057

^A The average of the laboratories' calculated averages.