



Designation: ~~D7380~~—15 D7380/D7380M – 21

Standard Test Method for Soil Compaction Determination at Shallow Depths Using ~~5-lb (2.3 kg)~~ 2.3-kg [5-lbm] Dynamic Cone Penetrometer¹

This standard is issued under the fixed designation ~~D7380~~D7380/D7380M; the number immediately following the designation indicates the year of original adoption or, in the case of revision, the year of last revision. A number in parentheses indicates the year of last reapproval. A superscript epsilon (ϵ) indicates an editorial change since the last revision or reapproval.

1. Scope*

1.1 This test method covers the procedure for the determination of the number of drops required for a dynamic cone penetrometer with a ~~5-lb (2.3 kg)~~2.3-kg [5-lbm] drop hammer falling ~~20 in. (508 mm)~~508 mm [20 in.] to penetrate a certain depth in compacted backfill.

1.2 The device is used in the compaction verification of fine- and coarse-grained soils, granular materials, and weak stabilized or modified material used in subgrade, base layers, and backfill compaction in confined cuts and trenches at shallow depth.

1.3 The test method is not applicable to highly stabilized and cemented materials or granular materials containing a large percentage of aggregates greater than ~~1.5 in. (37 mm)~~37 mm [1.5 in.].

1.4 The method is dependent upon knowing the field water content and the user having performed calibration tests to determine cone penetration resistance of various compaction levels and water contents.

1.5 Units—The values stated in either SI units or inch-pound units are to be regarded separately as standard. The values given in parentheses are mathematical conversions to SI units that are provided for information only and are not considered each system are not necessarily exact equivalents; therefore, to ensure conformance with the standard, each system shall be used independently of the other, and values from the two systems shall not be combined. Within the text of this standard, SI units appear first followed by the inch-pound [or other non-SI] units in brackets. Reporting of test results in units other than SI shall not be regarded as nonconformance with this standard.

1.6 It is common practice in the engineering profession to concurrently use pounds to represent both a unit of mass (~~lbm~~)[lbm] and a force (~~lbf~~)[lbf]. This implicitly combines two separate systems of units; that is, the absolute system and the gravitational system. This standard has been written using the gravitational absolute system of units when dealing with the inch-pound system. In this system, the pound (~~lbf~~)[lbf] represents a unit of force (weight). However, the use of balances or scales recording pounds of mass (~~lbm~~)[lbm] or the reading of density in lbm/ft^3 shall not be regarded as a nonconformance with this standard.

1.7 All observed and calculated values shall conform to the guidelines for significant digits and rounding established in Practice D6026.

¹ This test method is under the jurisdiction of ASTM Committee D18 on Soil and Rock and is the direct responsibility of Subcommittee D18.08 on Special and Construction Control Tests.

Current edition approved Nov. 1, 2015/Nov. 1, 2021. Published November 2015/November 2021. Originally approved in 2008. Last previous edition approved in 2008/2015 as ~~D7380–08~~D7380–15. DOI: ~~10.1520/D7380-15~~10.1520/D7380_D7380M-21.

*A Summary of Changes section appears at the end of this standard

1.8 *This standard does not purport to address all of the safety concerns, if any, associated with its use. It is the responsibility of the user of this standard to establish appropriate safety, health, and environmental practices and determine the applicability of regulatory limitations prior to use.*

1.9 *This international standard was developed in accordance with internationally recognized principles on standardization established in the Decision on Principles for the Development of International Standards, Guides and Recommendations issued by the World Trade Organization Technical Barriers to Trade (TBT) Committee.*

2. Referenced Documents

2.1 ASTM Standards:²

- D653 Terminology Relating to Soil, Rock, and Contained Fluids
- D698 Test Methods for Laboratory Compaction Characteristics of Soil Using Standard Effort (12,400 ft-lbf/ft³ (600 kN-m/m³))
- D1556 Test Method for Density and Unit Weight of Soil in Place by Sand-Cone Method
- D1557 Test Methods for Laboratory Compaction Characteristics of Soil Using Modified Effort (56,000 ft-lbf/ft³ (2,700 kN-m/m³))
- D2216 Test Methods for Laboratory Determination of Water (Moisture) Content of Soil and Rock by Mass
- D3740 Practice for Minimum Requirements for Agencies Engaged in Testing and/or Inspection of Soil and Rock as Used in Engineering Design and Construction
- D4959 Test Method for Determination of Water Content of Soil By Direct Heating
- D6026 Practice for Using Significant Digits and Data Records in Geotechnical Data
- D6938 Test Methods for In-Place Density and Water Content of Soil and Soil-Aggregate by Nuclear Methods (Shallow Depth)
- D6951 Test Method for Use of the Dynamic Cone Penetrometer in Shallow Pavement Applications
- E691 Practice for Conducting an Interlaboratory Study to Determine the Precision of a Test Method

3. Terminology

3.1 *Definitions*—For definitions of common technical terms used in this standard, refer to Terminology D653.

3.2 *Definitions of Terms Specific to This Standard:*

3.2.1 *5-lb (2.3-kg) dynamic cone penetrometer (5-lb (2.3-kg) DCP)*—(Fig. 1) a device that uses a 5-lb (2.3-kg) hammer to penetrate a cone tip inside the soil where the number of drops needed to penetrate a certain distance between two marks on the driving rod is used to determine soil compaction effort.

3.2.2 *extension rod*—in dynamic cone penetrometer, an optional extension of the driving rod to allow the use of the 5-lb (2.3-kg) DCP in deep confined holes.

3.2.2.1 *Discussion*—

The extension rod has a sliding sleeve with two markers similar to the ones on the 5-lb (2.3-kg) DCP driving rod for identifying the penetration distance and allowing the readings to be taken near or at the surface of the hole.

3.2.3 *electronic readout unit*—in dynamic cone penetrometer, optional readout device to automatically count the number of hammer drops and penetration distance inside the soil.

4. Summary of Test Method

4.1 The 5-lb (2.3-kg) DCP is placed vertically and the drop hammer is used to penetrate the soil until the lower mark on the driving rod is leveled with the surface of the soil.

4.2 The operator lifts the drop hammer to the upper stop disk and releases it, allowing it to fall freely under gravity and strike an anvil, causing the cone to be driven into the soil. The number of drops needed to penetrate the cone a distance 3.25 in. (83 mm) from the lower mark on the driving rod to the upper one is counted.

4.3 The number of drops is used to determine the pass or fail of soil compaction based on the results of calibration tests between the number of drops and soil percent compaction in similar soil of known percent compaction and water content.

² For referenced ASTM standards, visit the ASTM website, www.astm.org, or contact ASTM Customer Service at service@astm.org. For Annual Book of ASTM Standards volume information, refer to the standard's Document Summary page on the ASTM website.

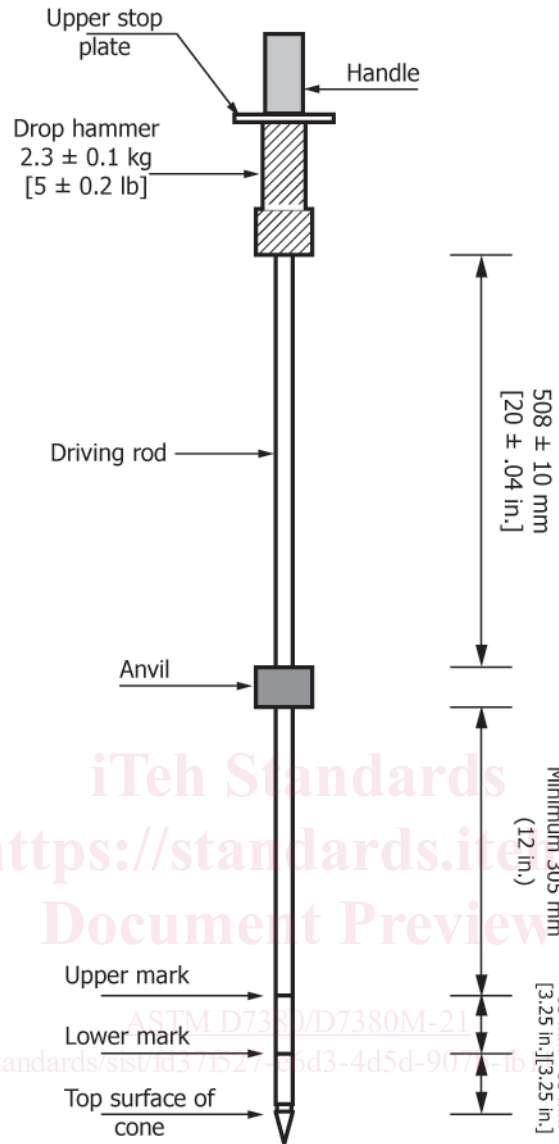

FIG. 1 Schematic Diagram of the 5-lbm DCP Device

5. Significance and Use

5.1 The test method is used to assess the compaction effort of compacted materials. The number of drops required to drive the cone a distance of 3.25 in. (83 mm) is used as a criterion to determine the pass or fail in terms of soil percent compaction.

5.2 The device does not measure soil compaction directly and requires determining the correlation between the number of drops and percent compaction in similar soil of known percent compaction and water content.

5.3 The number of drops is dependent on the soil water content. Calibration of the device should be performed at a water content equal to the water content expected in the field.

5.4 There are other DCPs with different dimensions, hammer weights, cone sizes, and cone geometries. Different test methods exist for these devices (such as D6951) and the correlations of the 5-lbm DCP with soil percent compaction are unique to this device.

5.5 The 5-lbm DCP is a simple device, capable of being handled and operated by a single operator in field conditions. It is

typically used as Quality Control (QC) of layer-by-layer compaction by construction crew in roadway pavement, backfill compaction in confined cuts and trenches, and utility pavement restoration work.

NOTE 1—The quality of results produced by this test method is dependent on the competence of the personnel performing it and the suitability of the equipment and facilities used. Agencies that meet the criteria of Practice D3740 are generally considered capable of competent and objective testing/sampling/inspection/etc. Users of this standard are cautioned that compliance with Practice D3740 does not in itself assure reliable results. Reliable results depend on many factors; Practice D3740 provides a means of evaluating some of these factors.

6. Apparatus

6.1 A schematic diagram of the 5-lb DCP is shown in Fig. 1. The device consists of an $1\frac{1}{4} \pm 1.6 \text{ mm}$ [$\frac{3}{4} \pm \frac{1}{16} \text{ in.}$ ($17.5 \pm 1.6 \text{ mm}$)-in.] steel rod with a $5 \pm 0.2 \text{ lb}$ ($2.3 \pm 0.1 \text{ kg}$)- $2.3 \pm 0.1 \text{ kg}$ [$5 \pm 0.2 \text{ lbm}$] drop hammer. The hammer drops a distance $20 \pm 0.4 \text{ in.}$ ($508 \pm 10 \text{ mm}$)- $508 \pm 10 \text{ mm}$ [$20 \pm 0.4 \text{ in.}$] between the upper stop plate and the anvil.

6.2 *Driving Rod*—The driving rod has two permanent marks or groves to monitor cone penetration depth. The lower mark is at a distance $3\frac{3}{4} \text{ in.}$ (83 mm)- 83 mm [3.25 in.] from the top surface of the cone and the distance between the two marks is 3.25 in. (83 mm)- 83 mm [3.25 in.].

6.3 *Cone Tip*—A replaceable cone tip of hardened steel or similar material with angle 25 ± 2 degrees is placed at the bottom of the driving rod. Fig. 2 shows the dimensions of the cone tip.

6.4 *Extension Rod*—An extension rod may be used to monitor compaction in deep cuts and narrow trenches where the operator has to work from the ground surface. The extension rod should be of the same diameter and material as the driving rod. Fig. 3 shows a schematic of the device with the extension rod used in a confined hole.

6.5 When the device is used in small holes and trenches, a sleeve is used to monitor the penetration distance from the surface as shown in Fig. 3. The lower mark on the sleeve is leveled with the ground surface using a straight edge and the sleeve is tightened by a screw to prevent it from moving during the test. Fig. 4 shows the dimensions of the sleeve.

6.6 The addition of extensions will change the mass of the device and the energy delivered to the cone. When extension rods and sleeves are used, calibration tests should be performed with these extensions attached to the device.

6.7 An automated electronic data readout unit may be used to register the number of drops and the penetrating distance. The system should give a signal and stop counting the number of drops once the penetration equals the distance from the lower mark to the top one.

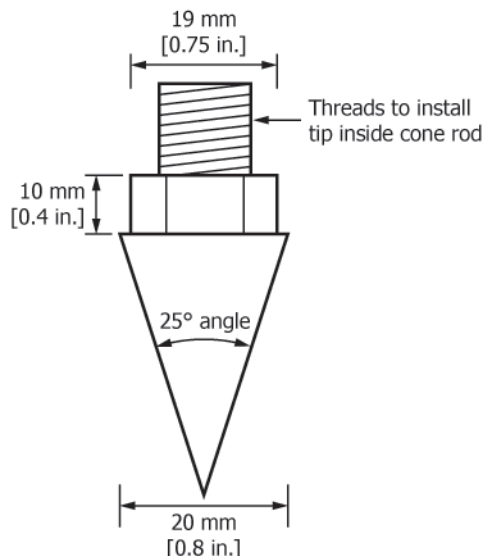

FIG. 2 Dimensions of the Cone Tip

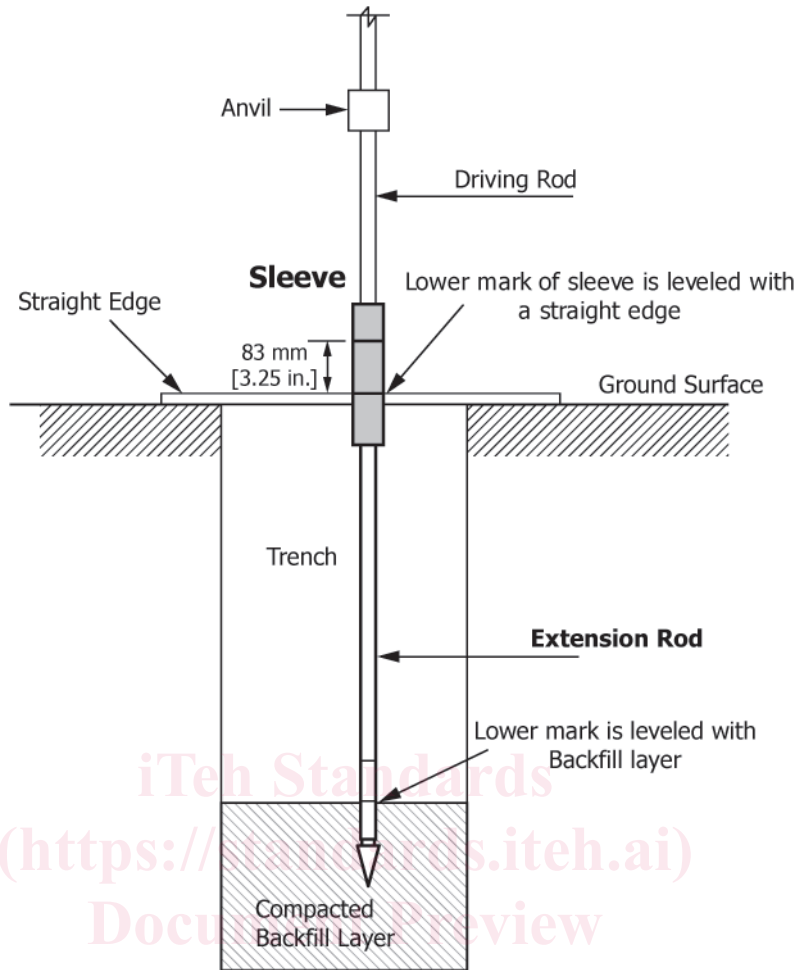

FIG. 3 Schematic of the 5-lb DCP with Extension Rod in Confined Excavation

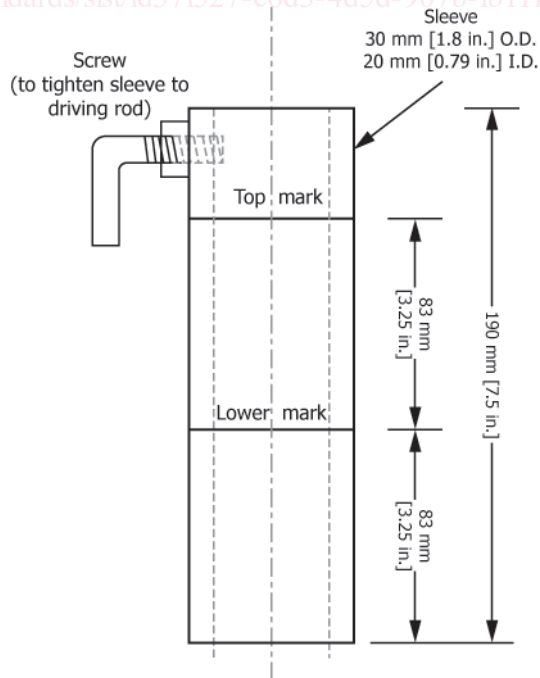

FIG. 4 Detail of the Sleeve Used with Extension Rod



6.8 The optional automated data readout unit should not interfere with the operation and results of the device. The output data of the system should satisfy the requirements of data reporting in Section 9.

7. Calibration

7.1 *Device preparation*—The device shall be inspected for damaged parts before testing; the cone tip angle should not be damaged and be within the acceptable tolerance before testing.

7.2 Soil sample preparation:

7.2.1 The soil percent compaction and optimum water content are determined for soil samples obtained from the field according to Test Method D698 or D1557 for laboratory compaction characteristics of soil as per the project compaction specifications.

7.2.2 A soil sample is obtained from the field to fill a 2-ft (610 mm) wide by 2-ft 610 mm [2 ft] wide by 610 mm [2 ft] long test pit with a depth of 12 in. (305 mm) 305 mm [12 in.]. The test pit can be constructed in the site or in the lab.

7.2.3 The soil is placed in the pit within $\pm 2\%$ of its optimum water content or as specified in the project compaction specifications. The soil water content in the pit is determined using Test Method D2216 or D6938.

7.2.4 The soil is compacted in two lifts, 6 in. (150 mm) 150 mm [6 in.] each using equal compaction effort in each lift. Initially, the soil is compacted using a low compaction effort. The soil density is measured using Test Method D6938 or D1556.

7.3 *Setup of the cone*—The operator holds the device vertically by the handle over the soil surface then lifts the drop hammer and releases it to cause the cone to penetrate until the lower mark on the driving rod is leveled with the surface of the soil layer.

7.4 *Cone testing*—The operator lifts the drop hammer to the upper stop disk and releases it, allowing it to fall freely under gravity. The hammer shall not unduly impact the upper disk when raised. The operator repeats the process and the number of drops needed to advance the cone a distance 3.25 in. (83 mm) 83 mm [3.25 in.] is recorded.

NOTE 2—In stiff soils, where the number of drops between the marks exceeds 20 drops at low compaction, the setup of the DCP test can be performed by dropping the hammer until only the top surface of cone (instead of the lower mark) is leveled with the surface of the soil. The testing is then performed by counting the number of drops for the distance of 3.25 in. (83 mm) 83 mm [3.25 in.] between the top surface of the cone and the lower mark as shown in Fig. 1. Record the starting point of testing in the report.

7.5 If the last drop needed to advance the cone 3.25 in. (83 mm) 83 mm [3.25 in.] overshoots the mark, then the last drop is not counted in the total number of drops.

7.6 The soil is removed from the test pit, replaced, and compacted using higher compaction efforts at the same water content. Steps 7.3 to 7.7 are repeated at higher compaction efforts until the compaction exceeds the specified percent compaction required in the field.

7.7 The number of hammer drops at each soil density is plotted against the corresponding soil percent compaction as shown in Fig. 5. A minimum of four points should be used to establish the calibration curve. At least one point should be within 2 % of the maximum percent compaction required in the field.

NOTE 3—Calibration of the device should be performed on samples representing the field water content. Calibration should be repeated if the calibration water content varies more than $\pm 2\%$ of the project standards. Calibration should also be performed when a new cone tip or a different tip angle is used to replace a deteriorated one.

8. Procedure

8.1 *Test site preparation*—Record site information, backfill type of each compacted lift, lift height, its optimum water content, and target percent compaction based on the standard or modified compaction tests in the lab.

8.2 Verify and record field water content using Test Method D2216 or D4959.

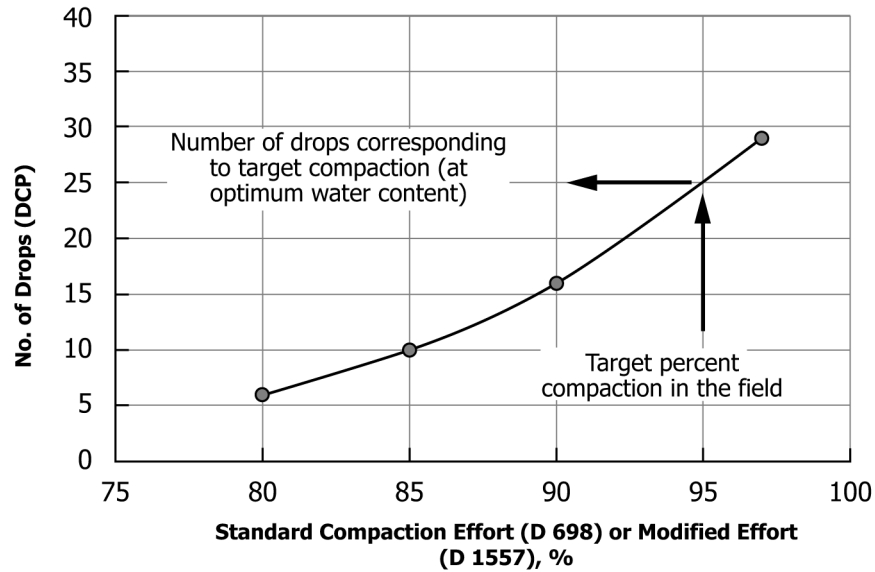

FIG. 5 Calibration of No. of Drops with Soil Percent Compaction

8.3 *Field testing at grade*—The operator performs steps 7.3 to 7.7 as in the calibration procedure to determine the number of hammer drops in the field.

8.4 The total number of drops is compared with the target number of drops at the same water content to establish the pass/fail compaction criteria. The pass criterion is established when the number of drops exceeds the target number of drops obtained from calibration.

8.5 It is recommended to use the device at least three times at each test section and take the average drop count. The readings should be taken at a minimum distance of 6 in. (150 mm) 150 mm [6 in.] from each other. If a soft zone or the presence of a rock causes one of the readings to be significantly different than the other readings in the layer, this reading should not be included in the averaging and it should be repeated in another location.

NOTE 4—It is recommended to take more than three readings when testing materials with high variability such as soils containing gravel and gravel type soil.

8.6 It is recommended to take more than three readings when testing materials with high variability such as soils containing gravel and gravel type soil.

8.7 *Testing a layer in a narrow trench below grade*—An extension rod is added to the driving rod when the device is used to monitor compaction in deep trenches. The sleeve shown in Fig. 4 is used if the operator can't see the markers on the rod inside the narrow trench. The lower mark of the sleeve is aligned with the ground surface to match the alignment of the lower mark of the cone rod with the backfill layer as shown in Fig. 3.

8.8 The operator performs the test as in Sections 7.3 to 7.7 and records the number of drops needed to advance the cone to the top mark of the sleeve.

9. Report: Test Data Sheet(s)/Form(s)

9.1 The methodology used to specify how data are recorded on the test data sheet(s)/form(s), as given below, is covered in 1.7 and in Practice D6026.

9.2 Record as a minimum the following general information for each Dynamic Cone Penetration test:

9.2.1 Operator name,