



Designation: ~~D1822~~—~~13~~ D1822 – 21

Standard Test Method for ~~Tensile-Impact Energy to Break Plastics and Electrical Insulating Materials~~Determining the Tensile-Impact Resistance of Plastics¹

This standard is issued under the fixed designation D1822; the number immediately following the designation indicates the year of original adoption or, in the case of revision, the year of last revision. A number in parentheses indicates the year of last reapproval. A superscript epsilon (ϵ) indicates an editorial change since the last revision or reapproval.

1. Scope*

1.1 This test method covers the determination of the energy required to rupture standard tension-impact specimens of plastic ~~or electrical-insulating materials~~. Rigid materials are suitable for testing by this method as well as specimens that are too flexible or thin to be tested in accordance with other impact test methods.

1.2 The values stated in SI units are to be regarded as standard. The values given in parentheses are for information only.

NOTE 1—This test method and [ISO 8256](#) address the same subject matter, but differ in technical content.

1.3 *This standard does not purport to address all of the safety ~~problems, concerns,~~ if any, associated with its use. It is the responsibility of the user of this standard to establish appropriate ~~safety~~ safety, health, and ~~health~~ environmental practices and determine the applicability of regulatory limitations prior to use.*

1.4 *This international standard was developed in accordance with internationally recognized principles on standardization established in the Decision on Principles for the Development of International Standards, Guides and Recommendations issued by the World Trade Organization Technical Barriers to Trade (TBT) Committee.*

2. Referenced Documents

2.1 ASTM Standards:²

[D256 Test Methods for Determining the Izod Pendulum Impact Resistance of Plastics](#)

[D618 Practice for Conditioning Plastics for Testing](#)

[D638 Test Method for Tensile Properties of Plastics](#)

[D883 Terminology Relating to Plastics](#)

[D4000 Classification System for Specifying Plastic Materials](#)

[D5947 Test Methods for Physical Dimensions of Solid Plastics Specimens](#)

[D6988 Guide for Determination of Thickness of Plastic Film Test Specimens](#)

[E177 Practice for Use of the Terms Precision and Bias in ASTM Test Methods](#)

[E456 Terminology Relating to Quality and Statistics](#)

[E691 Practice for Conducting an Interlaboratory Study to Determine the Precision of a Test Method](#)

2.2 ISO Standards:

[ISO 8256 Plastics—Determination of Tensile-Impact Strength](#)

¹ This test method is under the jurisdiction of ASTM Committee [D20](#) on Plastics and is the direct responsibility of Subcommittee [D20.10](#) on Mechanical Properties. Current edition approved ~~Sept. 1, 2013~~ Oct. 1, 2021. Published ~~November 2013~~ November 2021. Originally approved in 1961. Last previous edition approved in ~~2006~~ 2013 as ~~D1822–06~~ D1822–13. DOI: ~~10.1520/D1822–13~~ DOI: 10.1520/D1822–21.

² For referenced ASTM standards, visit the ASTM website, www.astm.org, or contact ASTM Customer Service at service@astm.org. For *Annual Book of ASTM Standards* volume information, refer to the standard's Document Summary page on the ASTM website. DOI: 10.1520/D1822-06.

*A Summary of Changes section appears at the end of this standard

3. Terminology

3.1 *Definitions*—~~Definitions of terms applying to this test method appear in~~ Terms used in this standard are defined in accordance with Terminology D883, unless otherwise specified. For terms relating to precision and bias and associated issues, the terms used in this standard are defined in accordance with Terminology E456.

4. Summary of Test Method

4.1 The energy utilized in this test method is delivered by a single swing of a calibrated pendulum of a standardized tension-impact machine. The energy to fracture a specimen, by shock in tension, is determined by the kinetic energy extracted from the pendulum of the impact machine in the process of breaking the specimen. One end of the specimen is mounted in the pendulum. The other end of the specimen is gripped by a crosshead which travels with the pendulum until the instant of impact (and instant of maximum pendulum kinetic energy), when the crosshead is arrested.

5. Significance and Use

5.1 Tensile-impact energy is the energy required to break a standard tension-impact specimen in tension by a single swing of a standard calibrated pendulum under a set of standard conditions (see Note 2). To compensate for the minor differences in cross-sectional area of the specimens, the energy to break is normalized to units of kilojoules per square metre (or foot-pounds-force per square inch) of minimum cross-sectional area. An alternative approach to normalizing the impact energy that compensates for these minor differences and still retains the test unit as joules (foot-pounds) is shown in Section 10. For a perfectly elastic material, the impact energy is usually reported per unit volume of material undergoing deformation. However, since much of the energy to break the plastic materials for which this test method is written is dissipated in drawing of only a portion of the test region, such normalization on a volume basis is not feasible. In order to observe the effect of elongation or rate of extension, or both, upon the result, the test method permits two specimen geometries. Results obtained with different capacity machines generally are not comparable.

5.1.1 With the Type S (short) specimen the extension is comparatively low, while with the Type L (long) specimen the extension is comparatively high. In general, the Type S specimen (with its greater occurrence of brittle fracture) gives greater reproducibility, but less differentiation among materials.

NOTE 2—Friction losses are largely eliminated by careful design and proper operation of the testing machine.

5.2 Scatter of data is sometimes attributed to different failure mechanisms within a group of specimens. Some materials exhibit a transition between different failure mechanisms. If so, the elongation will be critically dependent on the rate of extension encountered in the test. The impact energy values for a group of such specimens will have an abnormally large dispersion.

5.2.1 Some materials retract at failure with insignificant permanent set. With such materials, determining the type of failure, ductile or brittle, by examining the broken pieces is difficult, if not impossible. It is helpful to sort a set of specimens into two groups by observing the broken pieces to ascertain whether or not there was necking during the test. Qualitatively, the strain rates encountered here are intermediate between the high rate of the Izod test of Test Methods D256 and the low rate of usual tension testing in accordance with Test Method D638.

5.3 The energy for fracture is a function of the force times the distance through which the force operates. Therefore, given the same specimen geometry, it is possible that one material will produce tensile-impact energies for fracture due to a large force associated with a small elongation, and another material will produce the same energy for fracture result due to a small force associated with a large elongation. It shall not be assumed that this test method will correlate with other tests or end uses unless such a correlation has been established by experiment.

5.4 Comparisons among specimens from different sources are to be made with confidence only to the extent that specimen preparation, for example, molding history, has been precisely duplicated. Comparisons between molded and machined specimens must not be made without first establishing quantitatively the differences inherent between the two methods of preparation.

5.5 Only results from specimens of nominally equal thickness and tab width shall be compared unless it has been shown that the tensile-impact energy normalized to kilojoules per square metre (or foot-pounds-force per square inch) of cross-sectional area is independent of the thickness over the range of thicknesses under consideration.

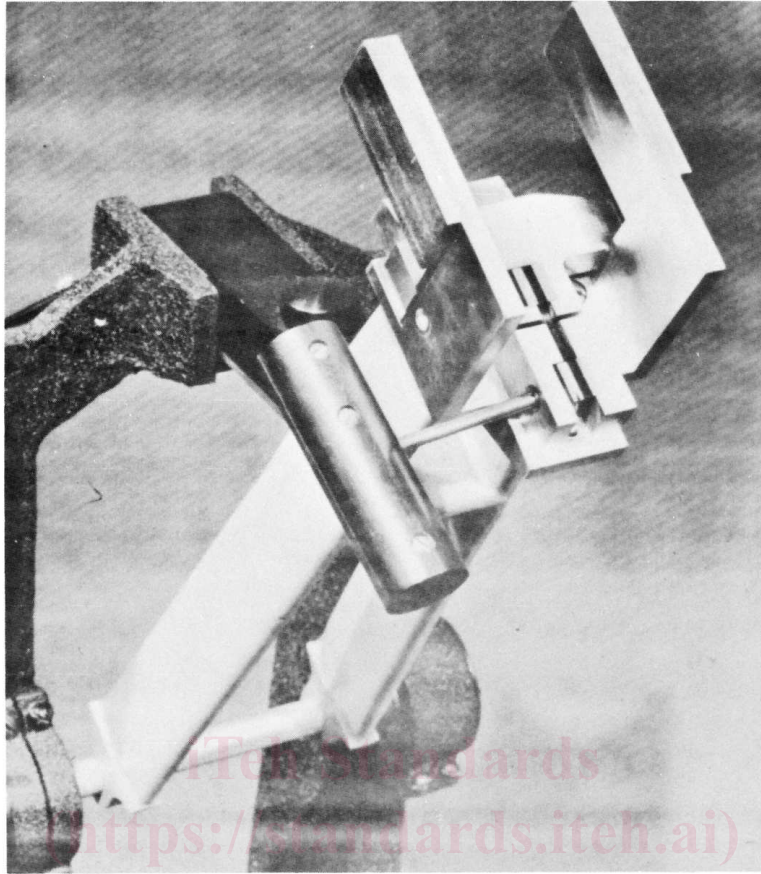

FIG. 1 Specimen-in-Head Tension-Impact Machine

ASTM D1822-21

5.6 The bounce of the crosshead supplies part of the energy to fracture test specimen (see Appendix X1).

5.7 For many materials, there are specifications that require the use of this test method, but with some procedural modifications that take precedence when adhering to the specification. Therefore, it is advisable to refer to that material specification before using this test method. Table 1 of Classification System D4000 lists the ASTM materials standards that currently exist.

6. Apparatus

6.1 The machine shall be of the pendulum type shown schematically in Fig. 1 and Fig. 2. The base and suspending frame shall be of sufficiently rigid and massive construction to prevent or minimize energy losses to or through the base and frame. The position of the pendulum holding and releasing mechanism shall be such that the vertical height of fall of the striker shall be $610 \pm 2 \text{ mm}$ ($24.0 \pm 0.1 \text{ in.}$). This will produce a velocity of the striker at the moment of impact of approximately 3.5 m (11.4 ft)/second (11.5 ft /second). The mechanism shall be so constructed and operated that it will release the pendulum without imparting additional acceleration or vibration.

6.2 The pendulum shall be constructed of a single- or multiple-membered arm holding the head, in which the greatest mass is concentrated. A rigid pendulum is essential to maintain the proper clearances and geometric relationships between related parts and to minimize energy losses, which always are included in the measured impact energy value. It is imperative that the center of percussion of the pendulum system and the point of impact are within $\pm 2.54 \text{ mm}$ ($\pm 0.100 \text{ in.}$) of each other and that the point of contact occurs in the neutral (free hanging) position of the pendulum within 2.54 mm (0.100 in.), both with and without the crosshead in place.

NOTE 3—The distance from the axis of support to the center of percussion is determined experimentally from the period of small amplitude oscillations of the pendulum by means of the following equation:

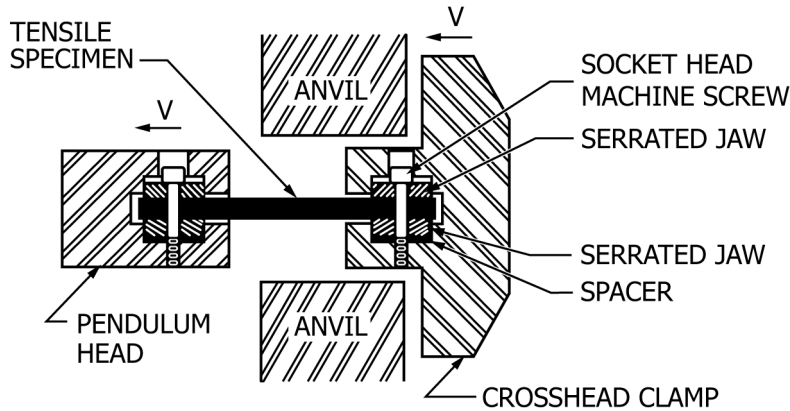

FIG. 2 Specimen-in-Head Tension-Impact Machine (Schematic)

$$L = (g/4\pi^2) p^2 \quad (1)$$

where:

L = distance from the axis of support to the center of percussion, mm (ft),

g = local gravitational acceleration (known to an accuracy of one part in one thousand), in mm/s² (ft/s²),

π = 3.14159, and

p = period, s, of a single complete swing (to and fro) determined from at least 50 consecutive and uninterrupted swings (known to one part in two thousand). The angle of swing shall be less than 0.09 radians (5°) each side of the center.

6.3 The positions of the rigid pendulum and crosshead clamps on the specimen are shown in Fig. 2. The crosshead is designed to be rigid and light in weight. The crosshead shall be supported by the pendulum so that the test region of the specimen is not under stress until the moment of impact, when the specimen shall be subjected to a pure tensile force. The clamps shall have file-like serrated jaws to prevent the specimen from slipping. The edge of the serrated jaws shall have a 0.40-mm (1/64-in.) radius to break the edge of the first serrations. The size of serrations will vary and shall be selected according to experience with hard and tough materials, and with the thickness of the specimen.

6.4 Means shall be provided for determining the energy expended by the pendulum in breaking the specimen. This is accomplished using either a pointer and dial mechanism or an electronic system consisting of a digital indicator and sensor (typically an encoder or resolver). standards.iteh.ai/catalog/standards/sist/415888ff-0bf4-4315-9ff5-0ff4bde4919d/astm-d1822-21

6.5 The indicated breaking energy is determined by detecting the height of rise of the pendulum beyond the point of impact in terms of energy removed from that specific pendulum.

6.5.1 Since the indicated energy must be corrected for pendulum-bearing friction, pointer friction, pointer inertia, and pendulum windage, instructions for making these corrections are found in Annexes A1 and A2 of Test Method D256. If the electronic display does not automatically correct for windage and friction, it shall be incumbent for the operator to determine the energy loss manually. (See Note 4.)

NOTE 4—Many digital indicating systems automatically correct for windage and friction. The equipment manufacturer may be consulted for details concerning how this is performed, or if it is necessary to determine the means for manually calculating the energy loss due to windage and friction.

6.5.2 Bounce correction is explained in Appendix X1. Some electronic displays permit the user to enter an energy correction offset so that the bounce correction is factored in before the breaking energy is displayed.

6.6 The procedures for the setup and calibration of tension-impact machines are described in Appendix X2.

6.7 *Micrometers*—Apparatus for measuring the width and thickness of the test specimen shall comply with the requirements of Test Method D5947 and D6988. For measuring the width of the restricted area of the Type S specimen, fit the anvil and spindle of the micrometer with a 4 to 8 mm (0.16 to 0.28 in.) nominal diameter double ball interface.

6.8 *Torque Wrench*, 0-8.5 N-m.

FIG. 3 Mold Dimensions of Types S and L Tension-Impact Specimens

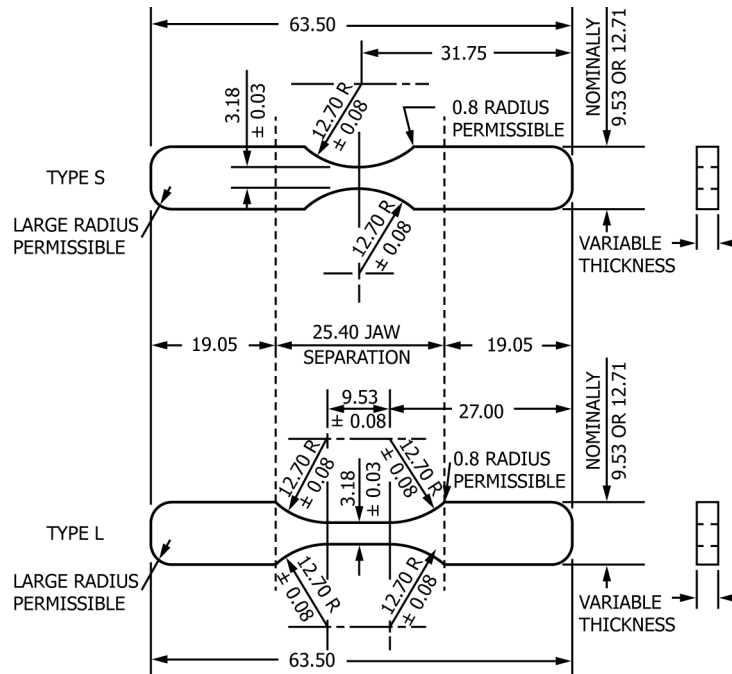

FIG. 3A Mold Dimensions of Types S and L Tension-Impact Specimens (Dimensioned in Millimetres)

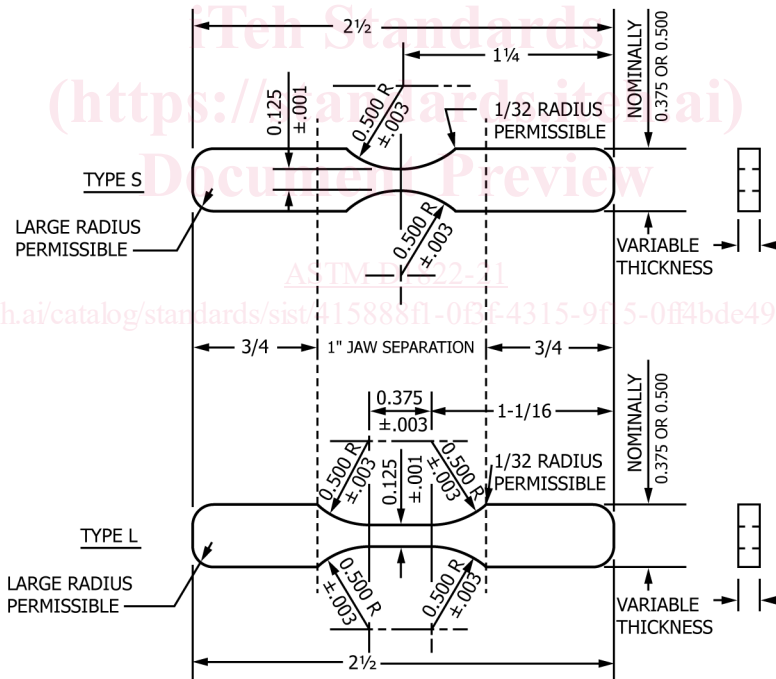

FIG. 3B Mold Dimensions of Types S and L Tension-Impact Specimens (Dimensioned in Inches)

7. Test Specimen

7.1 At least five and preferably ten specimens from each sample shall be prepared for testing. For sheet materials that are suspected of anisotropy, duplicate sets of test specimens shall be prepared having their long axis respectively parallel with, and normal to, the suspected directions of anisotropy.

7.2 The test specimen shall be sanded, machined, or die cut to the dimensions of one of the specimen geometries shown in Fig. 3, or molded in a mold whose cavity has these dimensions. Fig. 4A shows bolt holes and bolt hole location and Fig. 4B shows

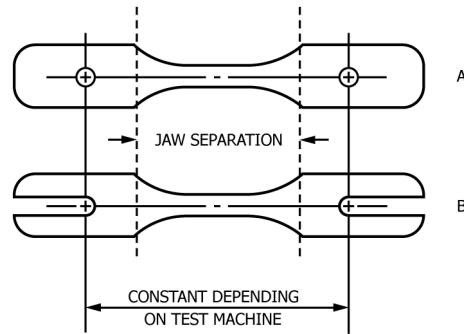

FIG. 4 Bolt Hole Location

a slot as an alternative method of bolting for easy insertion of the specimens into the grips. The No. 8-32 bolt size is recommended for the 9.53-mm (0.375-in.) wide tab and No. 8-32 or No. 10-32 bolt size is suggested for the ~~12.70-mm~~ 12.7-mm (0.500-in.) wide tabs. Final machined, cut, or molded specimen dimensions cannot be precisely maintained because of shrinkage and other variables in sample preparation.

7.3 A nominal thickness of 3.2 mm ($\frac{1}{8}$ in.) is optimum for most materials being considered and for commercially available machines. Thicknesses other than 3.2 mm ($\frac{1}{8}$ in.) are nonstandard and they shall be reported with the tension-impact value.

NOTE 5—Cooperating laboratories should agree upon standard molds and upon specimen preparation procedures and conditions.

8. Conditioning

8.1 *Conditioning*—Condition the test specimens in accordance with Procedure A of Practice D618, unless otherwise specified by contract or the relevant ASTM material specification. Conditioning time is specified as a minimum. Temperature and humidity tolerances shall be in accordance with Section 7 of Practice D618 unless specified differently by contract or material specification.

8.1.1 Note that for some hygroscopic materials, such as nylons, the material specifications call for testing “dry as-molded specimens.” Such requirements take precedence over the above routine preconditioning to 50 % relative humidity and require sealing the specimens in water vapor-impermeable containers as soon as molded and not removing them until ready for testing.

8.2 *Test Conditions*—Conduct the tests at the same temperature and humidity used for conditioning with tolerances in accordance with Section 7 of Practice D618, unless otherwise specified by contract or the relevant ASTM material specification.

9. Procedure

9.1 Measure the width and thickness of each specimen to the nearest 0.025 mm (0.001 in.) using the applicable test methods in Test Method D5947 or D6988. Record these measurements along with the identifying markings of the respective specimens.

9.2 Clamp the specimen to the crosshead while the crosshead is out of the pendulum. A jig to position the specimen properly with respect to the crosshead during the bolting operation is useful for some machines. With the crosshead properly positioned in the elevated pendulum, bolt or clamp the specimen at its other end to the pendulum itself, as shown in Fig. 1, using a torque wrench. To avoid excessive deformation of the specimens, use a torque suitable for the material being tested.

9.3 Use the lowest capacity pendulum available, provided that the specimens do not extract more than 85 % of the energy available. If this occurs, use a higher capacity pendulum.

NOTE 6—In changing pendulums, the tensile-impact energy will decrease as the mass of the pendulum is increased.

9.4 Slippage of specimens results in erroneously high values. Visually examine the tabs of the broken specimens for an undistorted image of the jaw faces, preferably under magnification, and compared against a specimen which has been similarly clamped but not tested. Because slippage has been shown to be present in many cases and suspected in others, the use of bolted specimens is mandatory. The function of the bolt is to assure good alignment and to improve the tightening of the jaw face plates. The bolt shall be tightened using a torque wrench. If slippage of the specimens in the clamp occurs, reject the specimen and increase the torque

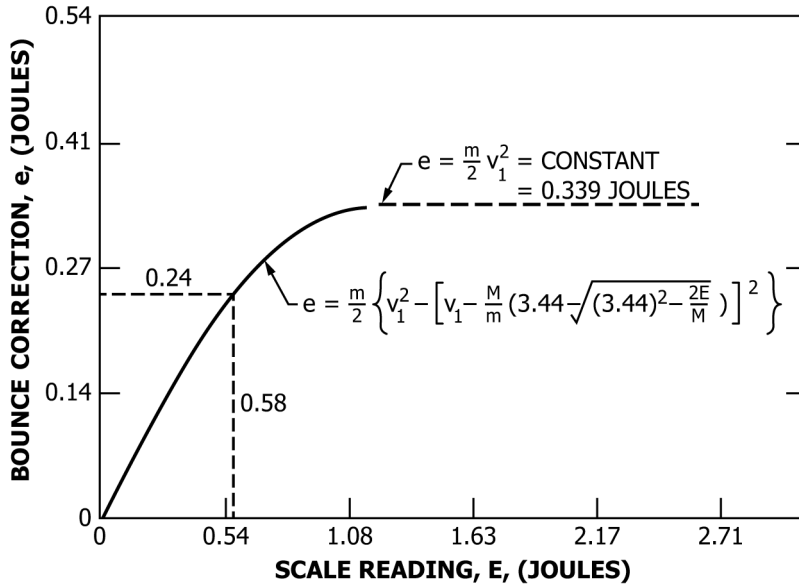

FIG. 5 Typical Correction Factor Curve for Single Bounce of Crosshead for Specimen-in-Head Tension-Impact Machine, 6.8-J Hammer, 0.428-lb Steel Crosshead (see Appendix X1)

the minimum amount necessary to eliminate the slippage while avoiding breaking or cracking the specimen due to excessive force. The clamping force selected for use on any one specimen is material dependent

9.5 Measure the tension-impact energy of each specimen and record its value, and comment on the appearance of the specimen regarding permanent set or necking, and the location of the fracture.

10. Calculation

10.1 Calculate the corrected impact energy to break as follows:

$$X = E - Y + e \tag{2}$$

where:

- X = corrected impact energy to break, in J (ft·lbf),
- E = scale reading of energy of break, in J (ft·lbf),
- Y = friction and windage correction in J (ft·lbf), and
- e = bounce correction factor, in J (ft·lbf) (Fig. 5).

NOTE 7—Fig. 5 is a sample curve. If desired, calculate a curve in accordance with Appendix X1 for the crosshead and pendulum used before applying any bounce correction factors.

NOTE 8—Examples: