



Designation: **F1233—08 (Reapproved 2019) F1233 – 21**

Standard Test Method for Security Glazing Materials And Systems¹

This standard is issued under the fixed designation F1233; the number immediately following the designation indicates the year of original adoption or, in the case of revision, the year of last revision. A number in parentheses indicates the year of last reapproval. A superscript epsilon (ϵ) indicates an editorial change since the last revision or reapproval.

1. Scope

1.1 This test method sets forth procedures whose purpose is limited to the evaluation of the resistance of security glazing materials and systems against the following threats:

1.1.1 *Ballistic Impact,*

1.1.2 *Blunt Tool Impacts,*

1.1.3 *Sharp Tool Impacts,*

1.1.4 *Thermal Stress,* and

1.1.5 *Chemical Deterioration.*

NOTE 1—Specifically exempted from this test method are the use of power (motor or engine-driven) tools or devices, explosives, military ordinance (excepting small arms) and tools, processes or devices requiring more than two persons to transport and operate.

1.2 The values stated in inch-pounds are to be regarded as the standard. The values given in parentheses are for information only.

1.3 *This standard does not purport to address all of the safety concerns, if any, associated with its use. It is the responsibility of the user of this standard to establish appropriate safety, health, and environmental practices and determine the applicability of regulatory limitations prior to use.* For a specific warning statement, see Warning in 10.1.1.6.

1.4 *This international standard was developed in accordance with internationally recognized principles on standardization established in the Decision on Principles for the Development of International Standards, Guides and Recommendations issued by the World Trade Organization Technical Barriers to Trade (TBT) Committee.*

2. Referenced Documents

2.1 *ASTM Standards:*²

[A36/A36M Specification for Carbon Structural Steel](#)

[A53/A53M Specification for Pipe, Steel, Black and Hot-Dipped, Zinc-Coated, Welded and Seamless](#)

[A574 Specification for Alloy Steel Socket-Head Cap Screws](#)

¹ This test method is under the jurisdiction of Committee F12 on Security Systems and Equipment and is the direct responsibility of Subcommittee F12.10 on Systems Products and Services.

Current edition approved Aug. 1, 2019; Oct. 15, 2021. Published August 2019; November 2021. Originally approved in 1989. Last previous edition approved in 2013 as F1233 – 08 (2013) (2019). DOI: 10.1520/F1233-08R19-10.1520/F1233-21.

² For referenced ASTM standards, visit the ASTM website, www.astm.org, or contact ASTM Customer Service at service@astm.org. For *Annual Book of ASTM Standards* volume information, refer to the standard's Document Summary page on the ASTM website.

F1029 Guide for Selection of Physical Security Measures for a Facility (Withdrawn 2004)³

2.2 *Other Documents:*

~~Sporting Arms and Ammunition Manufacturer's Institute (SAAMI) Arms and Ammunition Manufacturer's Institute (SAAMI)—
Ammunition—Ammunition~~⁴

~~United States Military Ammunition Specifications States Military—Ammunition-Specifications—Ammunition~~⁵

~~Federal Specification GGG-313U—Specification GGG-313U—Cold—Cold Chisel~~⁶

~~American Iron and Steel Institute M-1020 Iron and Steel Institute M-1020—Structural Steel—Structural Steel~~⁷

~~UL 10BC 10BC—Fire—Fire Extinguisher~~⁸

3. Terminology

3.1 Definitions:

3.1.1 *test director, n*—individual identified by the independent testing laboratory as being responsible to complete the specified tests as required and to document the results.

4. Class

4.1 *Ballistic Class*—Ballistic tests and test results from this standard shall be classified by the following (see also **Table 1**):

4.1.1 *HG1 Handgun - Low*—Ammunition conforming to SAAMI specifications for caliber .38 Special, 158 grain (~~10.2 g~~), (10.2 g), soft point, producing velocities of 875 (± 25) ft/s (266 (± 7) m/s) at 15 ft (4.5 m) from the muzzle.

4.1.2 *HG2 Handgun - Medium Soft Point*—Ammunition conforming to SAAMI specifications for caliber .357 Magnum, 158 grain (10.2 g), jacketed soft point, producing velocities of 1400 (± 50) ft/s (427 (± 15) m/s) at 15 ft (4.5 m) from the muzzle.

4.1.3 *HG3 Handgun - Medium Jacketed*—Ammunition conforming to SAAMI specifications for caliber 9 mm, 124 grain (8.0 g), full metal casing, producing velocities of 1250 (± 50) ft/s (381 (± 15) m/s) at 15 ft (4.5 m) from the muzzle.

4.1.4 *HG4 Handgun - High*—Ammunition conforming to SAAMI specifications for caliber .44 Magnum, 240 grain, lead gas check producing velocities of 1450 (± 50) ft/s (442 (± 15) m/s) at 15 ft (4.5 m) from the muzzle.

4.1.5 *SMG Submachine Gun*—Ammunition conforming to SAAMI specifications for caliber 9 mm, 124 grain (8.0 g), full metal casing producing velocities of 1400 (± 50) ft/s (~~427 (± 15)~~) (427 (± 15)) m/s) at 15 ft (4.5 m) from the muzzle.

4.1.6 *R1 Rifle - Light*—Ammunition conforming to U.S. Military specifications for caliber .223 (5.56 mm) NATO, M193 ball producing velocities of 3250 (± 50) ft/s (991 (± 15) m/s) at 15 ft (4.5 m) from the muzzle.

4.1.7 *R2 Rifle - Heavy Soft Point*—Ammunition conforming to SAAMI specifications for caliber .30-'06, 180 grain (11.7 g) soft point producing velocities of 2925 (± 75) ft/s (991 (± 15) m/s) at 15 ft (4.5 m) from the muzzle.

4.1.8 *R3 Rifle - Heavy Jacketed*—Ammunition conforming to SAAMI specifications for caliber .308 Winchester (~~7.62 mm~~), (7.62 mm), 147 grain (9.5 g), M80 Ball, full metal casing producing velocities of 2800 (± 50) ft/s (853 (± 15) m/s) at 15 ft (4.5 m) from the muzzle.

4.1.9 *R4-AP - Armor Piercing*—Ammunition conforming to U.S. Military specifications for caliber .30-'06, M2AP producing velocities of 2775 (± 50) ft/s (846 (± 15) m/s) at 15 ft (~~4.5 m~~) (4.5 m) from the muzzle.

4.1.10 *R5 - Ball Jacketed*—Ammunition conforming to U.S. Military specifications for caliber .50 M2 Ball, full metal casing producing velocities of 2810 (± 50) ft/s (856 (± 15) m/s) at 15 ft (4.5 m) from the muzzle.

³ The last approved version of this historical standard is referenced on www.astm.org.

⁴ Available from Sporting Arms and Ammunition Manufacturers' Association (SAAMI), Box 1075, Riverside, CT 06878. <http://www.saami.org>.

⁵ Available from ~~Standardization Documents Order Desk, Bldg. 4, Section D, DLA Document Services, Building 4/D, 700 Robbins Ave., Philadelphia, PA 19111-5094, Attn: NPODS.~~ <http://quicksearch.dla.mil>.

⁶ Available from General Services Adm., 7th and D Sts. SW, Washington, DC 20407. <https://www.gsa.gov>.

⁷ Available from American Iron and Steel Institute, 1000 16th St. NW, Washington, DC 20036 (AISI), 25 Massachusetts Avenue, NW, Suite 800, Washington, DC 20001. <https://www.steel.org>.

⁸ Available from Underwriters Laboratories, Inc., Laboratories (UL), UL Headquarters, 333 Pfingsten Rd., Northbrook, IL 60062; Road, Northbrook, IL, 60062. <http://www.ul.com>.

TABLE 1 Ballistic Criteria

Class	Weapon Description	Caliber	Bullet Mass ^A /Type ^B	Velocity ^C , ft/s (m/s)	Minimum No. of Impacts ^D
HG1	Handgun—Low	.38 Special	158 gr (10.2 g);	850–900	3
HG1	Handgun - Low	.38 Special	158 gr (10.2 g), lead lead	850 to 900 (259–274) (259 to 274)	3
HG2	Handgun—Medium, Soft Point	.357 Magnum	158 gr (10.2 g);	1350–1450	3
HG2	Handgun - Medium, Soft Point	.357 Magnum	158 gr (10.2 g), JSP JSP	1350 to 1450 (411–442) (411 to 442)	3
HG3	Handgun—Medium, Jacketed	9 mm	124 gr (8.0 g), FMC	1200–1300	3
HG3	Handgun - Medium, Jacketed	9 mm	124 gr (8.0 g), FMC	1200 to 1300 (365–396) (365 to 396)	3
HG4	Handgun—High	.44 Magnum	240 gr (15.6 g);	1400–1500	3
HG4	Handgun - High	.44 Magnum	240 gr (15.6 g), LGC LGC	1400 to 1500 (427–442) (427 to 442)	3
SMG	Submachine-gun	9 mm	124 gr (8.0 g), FMC	1350–1450	3
SMG	Submachine-gun	9 mm	124 gr (8.0 g), FMC	1350 to 1450 (411–442) (411 to 442)	3
R1	Rifle—Light	.223 (5.56 mm)	55 gr (3.6 g), M193	3200–3300	3
R1	Rifle - Light	.223 (5.56 mm)	55 gr (3.6 g), M193 Ball, FMC	3200 to 3300 (975–1006) (975 to 1006)	3
R2	Rifle—Heavy, Soft Point	.30-06	180 gr (11.7 g), SP	2850–3000	3
R2	Rifle - Heavy, Soft Point	.30-06	180 gr (11.7 g), SP	2850 to 3000 (867–914) (867 to 914)	3
R3	Rifle—Heavy, Jacketed	.308 Winchester	147 gr (9.5 g), M80	2700–2800	3
R3	Rifle - Heavy, Jacketed	.308 Winchester (7.62 mm) (7.62 mm)	147 gr (9.5 g), M80 Ball, FMC Ball, FMC	2700 to 2800 (823–853) (823 to 853)	3
R4-AP	Rifle—Armor Piercing	.30-06	166 gr (10.8 g);	2715–2850	1
R4-AP	Rifle - Armor Piercing	.30-06	166 gr (10.8 g), M2-AP M2-AP	2715 to 2850 (828–867) (828 to 867)	1
R5	Rifle—Jacketed	.50	709.5 gr (45.9 g)	2760–2860	1
R5	Rifle - Jacketed	.50	709.5 gr (45.9 g) Ball, FMC Ball, FMC	2760 to 2860 (841–867) (841 to 867)	1
SH1 ^E	Shotgun—Buckshot	12 gage,	00 buckshot,	1150–1250	1 ^F
SH1 ^E	Shotgun - Buckshot	12 gage, 3 in. Magnum 3 in. Magnum	00 buckshot, 15 pellets 15 pellets	1150 to 1250 (350–381) (350 to 381)	1 ^F
SH2	Shotgun—Slug	12 gage	1 oz. (437.5 gr, 28.3 g)	1600–1700	3
SH2	Shotgun - Slug	12 gage	1 oz. (437.5 gr, 28.3 g) rifled slug rifled slug	1600 to 1700 (487–518) (487 to 518)	3

^A gr denotes grain as a unit of mass; 1 gr = 1.429 × 10⁻⁴ lb (0.0647981 g).

^B FMC = Full Metal Casing, JSP = Jacketed Soft Point, LGC = Lead Gas-Check, and SP = Soft Point.

^C Velocity measured at a distance of 10 ft (3 m) from the strike face of the sample. Muzzle of the barrel is positioned at a distance of 25 ft (7.6 m) from the strike face of the sample.

^D Minimum number of shots required on glazed features plus additional shots to examine other features of the assembly. Prior to testing the intended impact location(s) shall be marked in the approximate center of the target area. Where 3 impacts are specified, they are to be located at the corners of a 5 in. (127 mm) equilateral triangle. The minimum spacing between impact locations is 4 in. (102 mm).

^E This ammunition is to be used as an adjunct to the primary test to further evaluate the ability of designed assembly details to resist fragmentary threats.

^F The shot pattern of the pellets shall be such that they all impact within an 8 in. (203 mm) diameter circle at a distance of 25 ft (7.62 m) from the muzzle of the weapon.

4.1.11 *SH1 - Shotgun - Buckshot*—Ammunition conforming to SAAMI specifications for Shotshell 12-gage, 3 in. Magnum, 00 Buckshot producing velocities of 1315 (±50) ft/s (400 (±15)–(400 (±15) m/s) at 15 ft (4.5 m) from the muzzle.

NOTE 2—The 12-gage ballistic threat is to be used as a confirmatory test of assemblies. Glazing materials are not to be tested or rated against this threat.

4.1.12 *SH2 - Shotgun - Slug*—Ammunition conforming to SAAMI specifications for Shotshell 12-gage, 1 oz. (437.5 g) rifled slug producing velocities of 1650 (±50) ft/s (503 (±15) m/s) at 15 ft (4.5 m) from the muzzle.

4.2 *Forced Entry Class*—See **Table 2**.

TABLE 2 Forced Entry Sequence of Testing

Sequence	Test Implements	Impacts	Minutes	Amount	Class Achieved
1	Ball Peen Hammer	10			1.0
2	Ball Peen Hammer	10			1.1
3	1½-in. (4-cm) Diameter Pipe/Sledge	25			1.2
4	Extinguisher, CO ₂		1		1.3
5	Sledge Hammer	25			1.4
6	Propane Torch Flame		5 ^A		1.5
7	Ripping Bar	10			2.0
8	Ram	10			2.1
9	4-in. (10-cm) Diameter Pipe/Sledge	25			2.2
10	Sledge Hammer	25			2.3
11	Propane Torch Flame		5 ^B		2.4
12	Ripping Bar	10			2.5
13	Chisel/Hammer	25			2.6
14	Gasoline	4		½ Pint (¼ L)	2.7
15	Angle Iron/Sledge	25			2.8
16	Sledge Hammer	25			3.0
17	Ram	10			3.1
18	4-in. (10-cm) Diameter Pipe/Sledge	25			3.2
19	Sledge Hammer	25			3.3
20	Propane Torch Flame		5 ^B		3.4
21	Wood Splitting Maul	25			3.5
22	Sledge Hammer	25			3.6
23	Ripping Bar	10			3.7
24	Fire Axe	25			3.8
25	Chisel/Hammer	25			3.9
26	Acetone			½ Pint (¼ L)	3.10
27	Sledge Hammer	25			4.0
28	Ram	10			4.1
29	4-in. (10-cm) Diameter Pipe/Sledge	25			4.2
30	Sledge Hammer	25			4.3
31	Propane Torch Flame		5 ^B		4.4
32	Fire Axe	25			4.5
33	Sledge Hammer	25			4.6
34	Wood Splitting Maul	25			4.7
35	Chisel/Hammer	25			4.8
36	Sledge Hammer	25			4.9
37	Acetone			½ Pint (¼ L)	4.10
38	Fire Axe	25			4.11
39	Sledge Hammer	25			4.12
40	Chisel/Hammer	25			4.13
41	Wood Splitting Maul	25			5.0

^A For Class 1.5, the flame shall be extinguished with a fine mist of water immediately after the propane torch application.

^B For Classes 2.4, 3.4, and 4.4, if the sample continues to burn after removal of the flame (self-sustaining), it shall be allowed to burn an additional 10 min and then extinguished with a fine mist of water.

5. Summary of Test Method

5.1 Forced entry shall be determined by resistance of the glazing material or system to the following:

5.1.1 Ballistics attack only.

5.1.2 Physical attack only to include blunt tool impacts, sharp tool impacts, thermal stress, and chemical deterioration.

5.1.3 Ballistics attack followed by, and in combination with, physical attack.

6. Significance and Use

6.1 This test method is based on field experience rather than laboratory analysis. It provides a basis for the comparative evaluation of ballistic/forced entry/containment resistance of security glazings and systems and should not be used to establish or confirm the absolute prevention of forcible entries or forced exits. This test method defines three factors which determine the success or failure of any attempt to forcefully enter (or exit) the glazing or system. They are: (1) the tools employed, (2) the techniques and methods used by the attackers, and (3) the total time available to effect the entry or exit. This test method defines two of the three factors (tools and techniques) and allows the third (duration) to vary in order to establish levels of forced entry or exit resistance.

7. Apparatus (Ballistics)

7.1 *Ballistic Firing Devices*—Firearms or test barrels suitable for use with the following calibers of ammunition producing minimum velocities as required:

- 7.1.1 *.38 Special*, 158 grain (10.2 g), lead,
- 7.1.2 *.357 Magnum*, 158 grain (10.2 g), jacketed soft point,
- 7.1.3 *9 mm*, 124 grain (8.0 g), full metal casing,
- 7.1.4 *.44 Magnum*, 240 grain (15.6 g), lead gas check,
- 7.1.5 *.223 (5.56 mm, M193 Ball)*, 55 grain (3.6 g), full metal casing,
- 7.1.6 *.30-’06*, 180 grain (11.7 g), soft point,
- 7.1.7 *.308 Winchester (7.62 mm, M80 Ball)*, 147 grain (10.5 g), full metal casing,
- 7.1.8 *.30-’06*, 165 grain (10.6 g), M2-AP (armor piercing),
- 7.1.9 *.50 caliber, 710 grain (46 g), M2-FMC Ball*,
- 7.1.10 *12 gage, 3 in. Magnum*, 00 Buckshot, 15 pellets, and
- 7.1.11 *12 gage, 1 oz. (437.5 grain, 28.3 g), rifled slug*.

7.2 *Ammunition Class*—All ammunition used in conducting tests within this test method shall be manufactured in compliance with current configurations and standards established by the Sporting Arms and Ammunition Manufacturer’s Institute (SAAMI) or United States Military Specifications, as applicable, except as may be noted within this test method.

7.3 *Witness Material:*

7.3.1 Aluminum foil, kitchen foil, or equivalent, 0.00094 in. (0.024 mm) \pm 10 % thick. Alloy may be 8111 or 1100, “0” temper.

7.4 *Instrumentation:*

7.4.1 *Photosensitive Triggering Screens*,⁹

7.4.2 *Chronograph*,⁹

7.4.3 *Thermometer*—Temperature ranges from +120 to ~~-30°F~~-30 °F (+49 to ~~-34°C~~)-34 °C).

7.5 *Test Frame and Stand:*

7.5.1 Samples of glazing submitted for testing shall be in sizes that would be encountered during normal use, but in no case smaller than 12 by 12 in. (30 by 30 cm) or larger than ~~29¾ by~~ by 29¾ in. (75 by 75 cm). The size and configuration of each sample will be such that it can be mounted in a structurally sound, rigid test fixture capable of accommodating a variety of sizes of rectangular samples. The framing must be affixed to the glazing sample in a manner which does not enhance or detract from the ballistic resistance of any portion of the sample to be ballistically impacted. For testing of glazing materials only, the mounting method is not subject to any tests herein.

7.6 *Test Set-Up:*

⁹ The sole source of supply of the apparatus known to the committee at this time is Oehler Research, P.O. Box 9135, Austin, TX 78766. If you are aware of alternative suppliers, please provide this information to ASTM International Headquarters. Your comments will receive careful consideration at a meeting of the responsible technical committee,¹ which you may attend.

7.6.1 The sample shall be mounted rigidly (bolted) to the test fixture to produce a zero degree ($\pm 3^\circ$) obliquity (ZDO) to the path of the bullet. Photosensitive triggering screens shall be positioned 5 and 15 ft (1.5 and 4.5 m) from the threat side of the sample which, in conjunction with an elapsed time counter or direct reading chronograph, shall be used to determine bullet velocities 10 ft (3 m) from the strike face of the sample. The test weapon shall be rigidly mounted at a distance of 25 ft (~~7.5 m~~) (7.5 m) from the muzzle to the target area of the test assembly. The test weapon shall be aimed to produce a zero degree obliquity trajectory to the target area within the tolerances of this test method.

7.6.2 The witness material shall be securely positioned parallel to, and no more than 6 in. (15 cm) behind (protected side), the target area of the test assembly. Curvilinear features of the target area shall therefore have the witness contoured to parallel these features. The witness material shall be stretched taut.

7.6.3 Should there be reason to suspect bullet flight stabilities, the test director is obligated to implement a paper witness panel, positioned 3 ft (91 cm) in front of the target area. This witness panel shall be inspected following each test firing as to indication of a yawed projectile. Evidence of a yawed or unstable projectile shall constitute an unfair hit, and shall require retesting.

7.6.4 The number and location of ballistic impacts required of this specification are minimum requirements. Further, the test director shall be obligated to conduct zero degree obliquity or oblique firings (as required by design) into the test specimen features that have design features passing completely or partially through the thickness of the glazing to examine all possible penetration paths. Not only shall the primary weapon/ammunition be used, but the 12-gage shotgun (as defined within this test method as an adjunct to the primary test) as well. The 12-gage ballistic threat is to be used as a confirmatory test of assemblies. Glazing materials are not to be tested or rated against this threat.

7.6.4.1 Due to chronograph/triggering screen accessibility, the test director may elect not to electronically measure muzzle velocities of certain oblique firings.

8. Apparatus (Physical Attack)

8.1 *Test Stand*—The test glazing samples will be mounted in a vertical test stand of rigid, 6 in. (15 cm) steel wide flange beams as in Fig. 1. The wide flange beam stand will be anchored in, or rigidly fixed to, a substantial concrete structure at each of its four corners (minimum requirements), and no linear dimension between supports of the test will exceed 8 ft (2.5 m).

8.2 *Test Frame:*

8.2.1 *Glazing Material Tests*—Unframed glazing samples will be mounted in a test frame detailed in Fig. 2 and Fig. 3, a weldment constructed of structural steel angle iron (conforming to Specification A36/A36M for 6 by 3½ by 5⁄8 in. (15 by 9 by 1.6 cm) which has a 1¼ in.² (3 cm²) steel bar fixed stop (conforming to Specification A36/A36M for 1¼ in.² (3 cm²) which will accept a square test sample of minimum 12 by 12 in. (30 by 30 cm) and maximum 29¾ by 29¾ in. (75 by 75 cm), and will allow ¼-in. (6-mm) clearance on all edges. The fixed stop square bar will be oriented to support the entire periphery of the sample facing the protected side for a maximum distance of 1.0 in. (2.5 cm) from its edge.

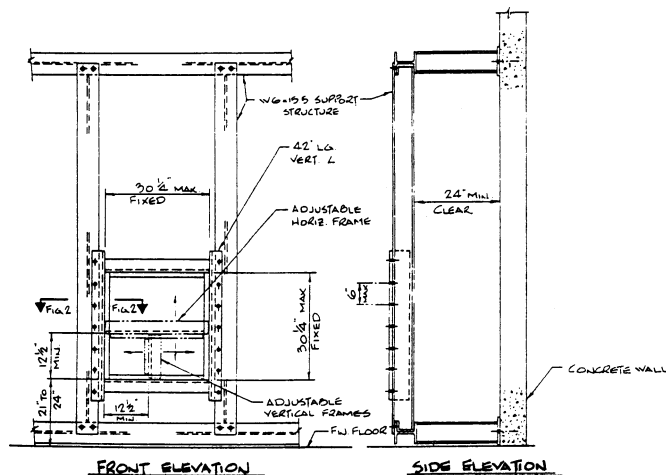

FIG. 1 Test Stand and Frame Assembly

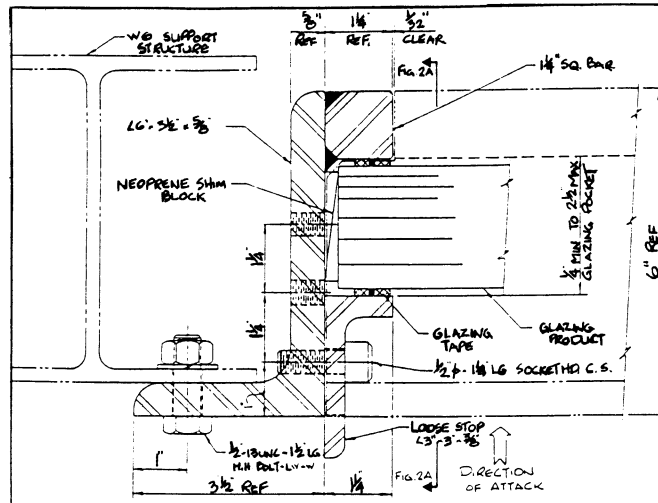

FIG. 2 Glazing Material Test Frame

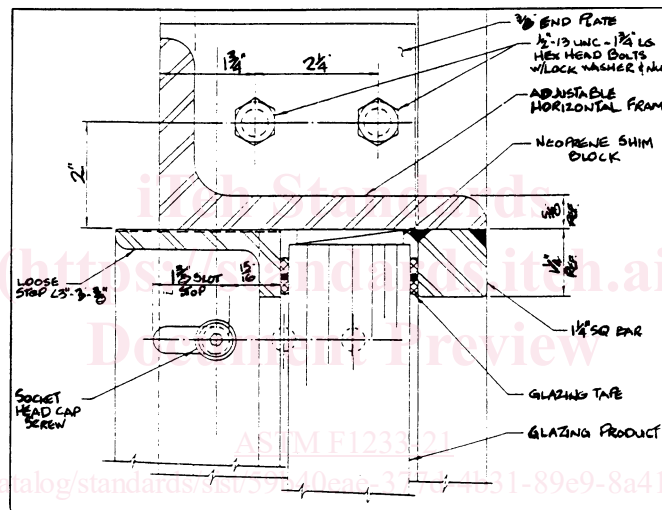

FIG. 3 Section of Glazing Material Test Frame

8.2.1.1 The test sample will rest at the bottom on two neoprene setting blocks ($\frac{1}{4}$ by 4-in. (6 by 100-mm) sample thickness) of 60 to 80 durometer placed at the quarter points. Prior to inserting the glazing sample in the test frame, a $\frac{3}{16}$ -in. (5-mm) glazing tape shall be applied to the fixed stop and adjustable stop where contact is made with the test sample.

8.2.1.2 The mounting is completed by bolting the adjustable stop to the test frame with $\frac{1}{2}$ -in. (13-mm) socket head cap screws (conforming to Specification A574) torqued to 120 ± 10 ft·lbf (163 ± 14 N·m) each. The center to center location of adjustable stop mounting bolts shall be no greater than 6 in. (15 cm). When the test sample is mounted it will be centered in the test frame and positioned with neoprene shims to result in not more than 1.0-in. (2.5-cm) edge coverage (bite) of the test sample.

8.2.1.3 Compression of the glazing tape will be made by the adjustable stop, but not to allow a test sample face to stop clearance of more than $\frac{1}{8}$ in. (3 mm). When mounted, the bottom edge of the exposed faces (protected and assaulted) of the sample will be no higher than 24 in. (61 cm) nor lower than 21 in. (53 cm) from the horizontal surface supporting the test (attack) personnel.

8.2.2 *Glazing System Tests*—The glazing system will be mounted in accordance with the manufacturer’s recommendations and shall be securely anchored so as the mounting system will not absorb any of the testing shock. Consideration should be given to, but is not limited to:

8.2.2.1 Overall size of glazing system.

8.2.2.2 Amount of “bite” within the frame.

8.2.2.3 Integrity of the frame.

8.2.2.4 Strength of base material.

8.2.2.5 Size of removable stop.

8.2.2.6 Removable stop fastener.

8.2.2.7 Interface between glazing and frame.

8.2.2.8 Integrity of anchorage of glazing system to adjoining architectural features.

8.3 *Blunt Impacting Tools:*

8.3.1 *Sledge Hammer*, 12-lb (5.5-kg), double-faced, drop-forged steel head with 36-in. (91-cm) handle.

8.3.2 *Pipe*, Steel, 4-in. (10-cm), in accordance with Specification **A53/A53M**, 90° cut-off.

8.3.3 *Ram*, Two man, 120-lb (54-kg), steel with 4 by 4-in. (10 by 10-cm) strike face and two 1-in. (2.5-cm) round handles mounted perpendicular to the longitudinal centerline extending 12 in. (30.5 cm) beyond the extremity of two opposing sides.

8.3.4 *Ball Peen Hammer*, 32-oz (0.5-kg), drop-forged, steel head, with 16-in. (41-cm) handle.

8.4 *Sharp Impacting Tools:*

8.4.1 *Ripping Bar*—Slotted claw and chisel ends, forged steel, 24 in. (61 cm).

8.4.2 *Cold Chisel*—Conforming to Federal Specification GGG-313U, 7/8-in. (22-mm) edge, 8 in. (20 cm) long, to be struck with 16-oz. (0.25-kg) claw hammer.

8.4.3 *Structural Steel Angle*, 20 by 2 in. (51 by 5 cm), 1/4 in. (6 mm) thick, AISI-M1020, 90° cut-off.

8.4.4 *Pipe*, Steel, 1½ in. (4 cm nominal) outside diameter, Schedule 80, in accordance with Specification **A53/A53M**, 90° cut-off.

8.4.5 *Fireman’s Axe-Pick Head*—Drop-forged steel, 6 lb (3 kg), 36 in. (91 cm) long.

8.4.6 *Wood Splitting Maul*, 8-lb (3.5-kg), heat-treated steel head with 3-in. (7.5-cm) cutting edge with 36-in. (91-cm) handle.

8.5 *Thermal Stress Tools:*

8.5.1 *Fire Extinguisher CO₂*—Steel cylinder, 20 lb (9 kg), conforming to UL 10BC, or equivalent.

8.5.2 *Propane Torch*, 12 to 15-oz (5.5 to 7-kg) cylinder with general purpose Tip No. HT-880-2,¹⁰ or equivalent.

8.6 *Chemically Deteriorating Materials:*

8.6.1 *Gasoline*—American Oil Company unleaded premium, 93 octane or equivalent.

8.6.2 *Solvent*, Containing acetone (minimum of 95 % concentration-technical grade).

¹⁰ The sole source of supply of the apparatus known to the committee at this time is Turner Companies, 821 Park Ave., Sycamore, IL 60178. If you are aware of alternative suppliers, please provide this information to ASTM International Headquarters. Your comments will receive careful consideration at a meeting of the responsible technical committee,¹ which you may attend.

8.6.3 *Dispenser*, Hand-operated, pump-type atomizing dispenser similar to that used for dispensing window cleaning solutions and other household products (polypropylene or polyethylene).

8.7 *Materials*:

8.7.1 *Forced Entry Shape*—A rigid, rectangular shape measuring 8 by 8 by 5 in. ($\pm 1/8$ in.) (20 by 20 by 13 cm (± 3 mm)) fabricated from 16 MSG steel.

8.8 *Test Personnel*:

8.8.1 Six males, muscular (180 to 250 lb (82 to 113 kg)), in good health, who carry out an enthusiastic assault.

8.8.2 No less than two members of the test team will be left-handed, and no less than two shall be right-handed.

8.9 *Test Specimens*:

8.9.1 *Number of Samples*—All testing is done on a single sample with the exception of extreme temperature firings as described in 9.2.1. Replicate testing is to be specified by the purchaser.

8.9.2 *Size of Samples*:

8.9.2.1 *Base Material Tests*—The size of all transparent glazing material samples will be no larger than $29\frac{3}{4}$ by $29\frac{3}{4}$ in. (75 by 75 cm) or smaller than 12 by 12 in. (30 by 30 cm). Sample size submitted for test shall be the installed size for the intended use, but in no case larger or smaller than the aforesaid dimensions. To facilitate fixturing, the sample thickness shall not be less than $\frac{1}{4}$ in. (6 mm) nor more than $2\frac{1}{2}$ in. (6.4 cm). The sample shall be submitted without framing, gaskets, or edging except that which is essential to maintaining any laminar spacing (or sealing of that spacing).

9. Preparation for Test

9.1 *Forced Entry Test Environment*—The location of the forced entry fixturing shall be in a protected environment whose ambient temperature is $72 \pm 5^\circ\text{F}$ ($22 \pm 3^\circ\text{C}$); $72 \pm 5^\circ\text{F}$ ($22 \pm 3^\circ\text{C}$). All test materials will be in this environment for a minimum of 24 h immediately preceding initiation of the test. The area immediately adjacent to the test sample extending 6 ft (1.8 m) to the left and right of either vertical edge of the sample, 10 ft (3 m) from the assault face of the sample, and 8 ft (2.4 m) over the horizontal surface supporting the test (attack) personnel, shall be free of all obstructions and appurtenances.

9.2 *Ballistic Test Environment*—The location of the ballistic test apparatus shall be in a protected environment whose ambient temperature is essentially at room temperature conditions $72 \pm 5^\circ\text{F}$ ($22 \pm 3^\circ\text{C}$); $72 \pm 5^\circ\text{F}$ ($22 \pm 3^\circ\text{C}$).

9.2.1 *Extreme Temperature Firings*—Extreme temperature ballistic testing of glazing materials intended for use in exterior applications shall be required. One sample shall be required for each of the following tests. The required temperature conditions must be maintained at the specimen surfaces until the first shot is fired. The 3 shots must be completed within 2 min from the time of the first shot. Glazing intended for interior use only shall have relief from these extreme temperature firings but must be permanently labeled FOR INTERIOR USE ONLY.

9.2.1.1 *High-Temperature Test*—Condition sample for 3 h at $+120 \pm 5^\circ\text{F}$ ($+49 \pm 3^\circ\text{C}$); $+120 \pm 5^\circ\text{F}$ ($+49 \pm 3^\circ\text{C}$).

9.2.1.2 *Cold-Temperature Test*—Condition sample for 3 h at $-20 \pm 5^\circ\text{F}$ ($-29 \pm 3^\circ\text{C}$); $-20 \pm 5^\circ\text{F}$ ($-29 \pm 3^\circ\text{C}$).

9.2.1.3 *Temperature Gradient Test (Winter)*—Condition strike face of sample for 3 h at $-20 \pm 5^\circ\text{F}$ ($-29 \pm 3^\circ\text{C}$); $-20 \pm 5^\circ\text{F}$ ($-29 \pm 3^\circ\text{C}$) with edges and rear face at ambient ($+70 \pm 10^\circ\text{F}$ ($+70 \pm 10^\circ\text{F}$ or $21 \pm 5^\circ\text{C}$); $21 \pm 5^\circ\text{C}$).

9.2.1.4 *Temperature Gradient Test (Summer)*—Condition strike face of sample for 3 h at $+120 \pm 5^\circ\text{F}$ ($48 \pm 3^\circ\text{C}$); $+120 \pm 5^\circ\text{F}$ ($48 \pm 3^\circ\text{C}$) with edges and rear face at ambient ($+70 \pm 10^\circ\text{F}$ ($+70 \pm 10^\circ\text{F}$ or $21 \pm 5^\circ\text{C}$); $21 \pm 5^\circ\text{C}$).

10. Procedures

10.1 *Ballistic Test*—Twelve primary ballistic classes (see 4.2) establish varying degrees of protection. The shotgun is used to further evaluate the ability of designed-through openings to resist fragmentary threats.

10.1.1 *Procedure*—Ammunition of the appropriate type and caliber shall be single fired to obtain the required number of fair hits on each glazing sample according to Table 1. The separation between any two ballistic impacts on a single contiguous area of glazing shall be no less than 4 in. (10 cm) center-to-center.

10.1.1.1 After each firing, the witness panel on the protected side shall be inspected visually. Only a complete perforation of the witness panel, whether by bullet fragments or material from the test sample (spall), shall be classified as a “penetration.” Any perforation of the witness panel through which the light from a 40-W incandescent lamp can be detected shall be termed a “penetration.” Impacts which produce any other results will be classified as “no penetration.” These definitions shall apply whether or not the test sample has been completely perforated. In the case of extreme temperature firings (9.2.1), the visual inspection may be completed after the last of the required firings are completed

10.1.1.2 For purposes of this test method, a fair hit shall be a zero degree obliquity ballistic impact ($\pm 3^\circ$) using the specified weight and type of unyawed bullet (3° maximum) within the specified velocity range on the specified location of the test sample. All other firings shall be classified as unfair except:

10.1.1.3 An impact at less than the minimum acceptable velocity which results in penetration but which is otherwise a fair hit shall be classified as a fair hit.

10.1.1.4 An impact at more than the maximum acceptable velocity which does not produce penetration but which is otherwise a fair hit shall be classified as a fair hit.

10.1.1.5 Oblique shots required by the test director because of suspected weak points.

10.1.1.6 All firings shall be conducted after the sample has been conditioned to the ambient temperature range for a maximum of 4 h and shall continue until the required number of non-penetrating fair hits or a single penetrating fair hit is (are) obtained, whichever occurs first. (**Warning**—Personal safety during ballistic tests is paramount and shall be strictly enforced by the test director to preclude injury to those persons conducting or observing the tests, or both.)

10.1.2 *Data*—Data records of each firing will be maintained and submitted with the test report by the testing laboratory, and shall include the following:

10.1.2.1 Complete identification of the test sample.

10.1.2.2 Ballistic class of test sample (see Annex A2).

10.1.2.3 Temperature of the test sample, if different from the ambient temperatures.

10.1.2.4 Type and lot number of the test ammunition.

10.1.2.5 Velocity and impact location of each shot.

10.1.2.6 Fair/unfair, penetration/no penetration, and spall/no spall determination of each shot.

10.1.2.7 Date, location, and ambient temperature of the test.

10.1.2.8 Photograph (test director’s and manufacturer’s option) of sample before and after each shot or complete test, or both.

10.1.3 *Reporting*—After completion of all testing, a comprehensive test report shall be prepared by the test laboratory which will specify the date, location, and results of the test and shall include, as appendices thereto, all data and photographs (see 10.1.2).

10.1.4 *Acceptance Criteria*—Where samples are submitted for *ballistic classification*, any fair hit which produces a “penetration” shall be cause to reject the sample and prohibit the labeling and use of that design of that glazing type as a bullet-resisting element for the ballistic classification tested, regardless of the number of other fair hits which did not produce “penetration.”

10.1.5 *Resubmission*—Failure of any glazing material to demonstrate full compliance with the requirements of 10.1.1 does not preclude the modification and resubmission of that design of the glazing for retesting. All such retesting shall be conducted in accordance with the full range of the requirements of this test method even though the glazing may have demonstrated partial compliance with the requirements of this test method.

10.2 *Forced Entry Testing:*

10.2.1 Any glazing sample or assembly to be evaluated as a forced entry barrier shall be subjected to forced entry testing in accordance with 10.2.4, 10.2.5, and Annex A1.

10.2.2 *Optional Ballistic Testing*—When required, ballistic testing may be performed on any glazing sample in accordance with 10.1. Following ballistic testing, the same sample will be subjected to forced entry testing.

10.2.3 *Optional Ballistic Testing Acceptance Criteria—Criteria:* ~~When forced entry samples are being tested for ballistics, “penetration” without a complete perforation of the test sample shall be noted but is not cause for rejection of the sample.~~

10.2.3.1 When forced entry samples are being tested for ballistics classification, “penetration” without a complete perforation of the test sample shall be noted but is not cause for rejection of the sample.

10.2.3.2 When forced entry samples are being subjected to ballistic assault prior to forced entry classification for the purpose of weakening the glazing, “perforation” of the test sample shall be noted but not cause for rejection or failure of the sample.

10.2.4 *Forced Entry Acceptance Criteria*—Any glazing sample breached sufficiently to allow the following categories shall be determined to have been forcibly entered.

10.2.4.1 *Passage of Contraband*—Any penetration of the glazing material such that a 1/8-in. (3-mm) diameter solid shape can be probed and passed through the glazing test specimen will be considered a failure for the passage of contraband by forcible entry. These criteria will apply whether free passage of the shape is made through a hole in the glazing or through the gap created by dissociation of the glazing material from its frame.

10.2.4.2 *Body Passage*—Any opening in the glazing that is sufficient to freely pass a solid incompressible rectangular object measuring 8 by 8 by 5 in. (20 by 20 by 13 cm) constitutes a failure by forcible entry. Free passage is defined as passing the object through the opening with an applied force no greater than 10 lb (4.4 N). This criterion will apply whether the free passage of the shape is made through a hole through the glazing or through the gap created by dissociation of the glazing material from its frame.

10.2.4.3 *Flame Test*—After removal of the flame of the propane torch and immediately extinguishing any self-sustained burning for Class II (Table 2, Sequence 6), or removal of the flame and the 10-min self-sustained burning period for Classes II-C, III-C, and IV-C (Table 2, Sequences 11, 20, 31), the sample will be determined to have been forcibly entered if:

(a) The size of any hole entirely through the sample of Class I-C created by the propane torch application allows passage of contraband (see 10.2.4.1) or body passage (see 10.2.4.2), or,

(b) The burning of the sample of Classes II-C, III-C, and IV-C is self-sustaining for a period of 10 min, and the size of any hole through the sample (whether created previously or by the flame test) increases in size by self-sustained burning to allow passage of contraband (see 10.2.4.1) or body passage (see 10.2.4.2).

10.2.5 *Forced Entry Test*—The glazing test sample shall be tested in accordance with the sequence of Table 2 until entry is forced.

10.2.6 *Data*—Data records of all testing will be maintained and submitted with the following:

10.2.6.1 Complete identification of the test sample.

10.2.6.2 Forced entry class of test sample (see Annex A2).

10.2.6.3 Temperature of the test sample, if different from ambient.

10.2.6.4 Complete description of the attack, including number of attackers, tools, impacts, and overall time of the attack.

10.2.6.5 Specific features of the sample attacked, tools used to attack that feature, and elapsed time for each segment of the attack.