

# INTERNATIONAL STANDARD

**ISO**  
**5085-2**

First edition  
1990-12-01

---

---

## Textiles — Determination of thermal resistance —

### Part 2:

**High thermal resistance**  
**(standards.iteh.ai)**

*Textiles — Détermination de la résistance thermique —*

*ISO 5085-2:1990*

*Partie 2: Résistance thermique élevée*

<https://standards.iteh.ai/catalog/standards/sis/5085-2-1990/5085-aa09-b65e63e7a3c6/iso-5085-2-1990>



Reference number  
ISO 5085-2:1990(E)

## Foreword

ISO (the International Organization for Standardization) is a worldwide federation of national standards bodies (ISO member bodies). The work of preparing International Standards is normally carried out through ISO technical committees. Each member body interested in a subject for which a technical committee has been established has the right to be represented on that committee. International organizations, governmental and non-governmental, in liaison with ISO, also take part in the work. ISO collaborates closely with the International Electrotechnical Commission (IEC) on all matters of electrotechnical standardization.

Draft International Standards adopted by the technical committees are circulated to the member bodies for voting. Publication as an International Standard requires approval by at least 75 % of the member bodies casting a vote.

International Standard ISO 5085-2 was prepared by Technical Committee ISO/TC 38, *Textiles*.

ISO 5085 consists of the following parts, under the general title *Textiles* — *Determination of thermal resistance*:

- Part 1: *Low thermal resistance*
- Part 2: *High thermal resistance*

iTeh STANDARD PREVIEW  
(standards.iteh.ai)

<https://standards.iteh.ai/catalog/standards/sist/5d9cd009-3994-4bf5-aa09-b65e63e7a3c6/iso-5085-2-1990>

## Introduction

The thermal insulation provided by woven and knitted fabrics and non-woven fibre aggregates (fleeces, batts and wads) is of considerable practical significance in connection with the use of these materials as clothing (especially cold-weather clothing), bedding (blankets, quilts), carpets, roof insulation, etc.

The measurement of the thermal resistance of textiles allows the incorporation of the values for clothing and furnishing fabrics into calculations for thermal environments, heat losses from rooms, etc. Thermal resistances of layers of fabrics are additive, thus values for whole clothing assemblies can be calculated.

The method of test can be easily adapted to allow for provision of air gaps between layers of fabric.

It has been suggested that a simple measurement of thickness provides an adequate measure of the thermal insulation of, say, blankets. This is only acceptable, however, if a common value can be assumed for the thermal insulation per unit thickness. However, the transmission of heat through a textile can occur not only by conduction through the fibres and the entrapped air but also by radiation through the air spaces within the fabric. Because of this, there is a considerable variation in the thermal insulation per unit thickness, and thickness is, therefore, an unreliable guide to the warmth provided by, say, blankets even when they are of one type (e.g. raised, cellular or terry).

ISO 5085 is published in two parts. This part is suitable for the determination of high thermal resistances, i.e. from about 0,2 m<sup>2</sup>·K/W to about 2,0 m<sup>2</sup>·K/W. For values less than about 0,2 m<sup>2</sup>·K/W, the method specified in ISO 5085-1 is suitable.

**iTeh STANDARD PREVIEW**  
**(standards.iteh.ai)**

This page intentionally left blank

[ISO 5085-2:1990](#)

<https://standards.iteh.ai/catalog/standards/sist/5d9cd009-3994-4bf5-aa09-b65e63e7a3c6/iso-5085-2-1990>

# Textiles — Determination of thermal resistance —

## Part 2: High thermal resistance

### 1 Scope

This part of ISO 5085 specifies a method for the determination of the resistance of fabrics, fabric assemblies or fibre aggregates in sheet form to the transmission of heat through them in the "steady state" condition. It applies to materials whose thermal resistance is within about 0,2 m<sup>2</sup>·K/W to 2,0 m<sup>2</sup>·K/W.

### 2 Normative reference

The following standard contains provisions which, through reference in this text, constitute provisions of this part of ISO 5085. At the time of publication, the edition indicated was valid. All standards are subject to revision, and parties to agreements based on this part of ISO 5085 are encouraged to investigate the possibility of applying the most recent edition of the standard indicated below. Members of IEC and ISO maintain registers of currently valid International Standards.

ISO 139:1973, *Textiles — Standard atmospheres for conditioning and testing*.

### 3 Definition

For the purposes of this part of ISO 5085, the following definition applies.

**thermal resistance, *R***: The ratio of the temperature difference between the two faces of a test specimen to the rate of flow of heat per unit area normal to the faces. It is analogous to electrical resistance in the case of current flow through an electrical conductor.

### 4 Principle

The thermal resistance is obtained by measuring the energy required to maintain an invariable difference of temperature in a heating body covered with the fabric to be tested as compared with the ambient temperature.

### 5 Apparatus<sup>1)</sup>

**5.1 Flat-topped heating body (B)** (see figures 1, 2 and 3), with electrical heating elements. The heating body comprises five blackened plates in an insulating case measuring 800 mm × 650 mm × 250 mm and with a 570 mm × 430 mm opening at the top. The heating body rests on a reinforced metal stand (A) which acts as the cold plate. The five plates making up the heating body are as follows:

**5.1.1 Two blackened metal plates**, incorporating a network of electrical resistors, and together forming the heating element (D).

**5.1.2 A plastics sheet (E).**

**5.1.3 An insulating plate** (made of polyurethane foam, for instance), of thermal resistance between 0,2 m<sup>2</sup>·K/W and 0,8 m<sup>2</sup>·K/W, and incorporating a thermopile, forming the measurement sensor (F). The thermopile, has 25 brass discs (H) on each face; these are distributed over a rectangular area measuring 570 mm × 430 mm.

**5.1.4 A contact plate (G)**, located uppermost in the stack (i.e. immediately under the test specimen) in order to distribute the heat.

1) For details of suppliers of suitable apparatus, apply to national standards institutions.

## 5.2 Measurement and control unit (C) (see figure 1).

The temperature of the heating element (D) is regulated by means of a differential control circuit using the readings from two temperature sensors, one in contact with the heating element and the other in contact with the cold plate (A).

The measurement sensor (F) generates an electrical voltage which is measured by a digital voltmeter and from which the results are calculated.

The equipment shall have a voltage measurement accuracy of  $\pm 1\%$  or better.

## 6 Atmosphere for conditioning and testing

Place the equipment in a room where there are no draughts and in which the rate of change of temperature is less than 1 K/h. The temperature and relative humidity inside the room shall be as normally found inside a dwelling in the country of test.

In some air-conditioned premises, small but rapid temperature fluctuations can occur. Such premises shall be avoided.

## 7 Test specimens

### 7.1 General

The test may be performed on specimens taken from a piece of fabric or from a finished article, or on the uncut finished article itself; in the case of a finished article, the test may be performed on a part including slide fasteners, pockets or stitching.

When a test specimen is taken from an article or other piece, proceed as indicated in 7.2 and 7.3.

### 7.2 Cutting out the specimen

Leave the sample lying flat for 24 h to allow it to assume its natural thickness. Take the specimen by cutting the fabric (or article) while it is flat, from an area where there are no faults.

### 7.3 Dimensions

The minimum size of the specimen shall be 600 mm  $\times$  450 mm. To measure the dimensions, simply lay the specimen on the measurement surface.

### 7.4 Number

Carry out the test on two specimens representing two different points on the same article or carry out the test on two different articles.

If necessary, to meet particular requirements, supplementary tests may be performed (using a larger number of specimens).

## 8 Procedure

### 8.1 Warming up the apparatus

In the event of discontinuous operation, 4 h warming-up is necessary.

### 8.2 Measurement

When the test is to be performed on an article with a removeable lining, first place it on a sufficiently large table and even out the lining (see also clause 10).

**8.2.1** Place the first specimen on the heating body (B) so that it covers at least the entire heated surface. When the article in its finished form is large, ensure the free circulation of air in the vicinity of the apparatus. Wait as long as necessary for two successive values read at intervals of 15 min from the voltmeter to differ by less than 1%. Record the value read as  $U_1$ . If the difference between successive readings remains greater than 1%, continue the test until any two measurements are obtained on the voltmeter with less than 1% difference.

**NOTE 1** For information, light fabrics stabilize in about 1 h whereas a heavy fabric takes about 4 h to stabilize.

Make similar measurements on the second specimen and record the value  $U_2$ .

Calculate the average of  $U_1$  and  $U_2$  and record it as  $U$ .

**8.2.2** If  $U_1$  and  $U_2$  differ by more than 5%, test two additional specimens. If the difference between  $U_1$  and  $U_2$  for the two additional specimens is greater than for the first two specimens, record the individual calculated values of the thermal resistance in the test report, without calculating the average.

**8.2.3** Remove the specimen, wait 1 h for the apparatus to restabilize, and record the reading  $U_0$  indicated on the digital voltmeter. Wait a further 15 min and again record the reading of the voltmeter. The two values shall not differ by more than 1%. If they do, wait a further 1 h and repeat the operations specified in this paragraph until two readings differing by less than 1% are obtained at an interval of 15 min.

**NOTE 2** When first starting up the apparatus, it is advisable to allow it to operate alone for a few hours, noting successive values of  $U_0$ . The use of a recorder can give

valuable information on the operating and environmental conditions.

## 9 Expression of results

Calculate an approximate thermal resistance using the following formula, expressing the result in square-metre kelvins per watt to the nearest 0,01 m<sup>2</sup>·K/W:

$$\left( \frac{U_0}{U} - 1 \right) k$$

where

$k$  is a coefficient characteristic of the apparatus used ( $k \approx 10$ );

$U$  and  $U_0$  are as defined in 8.2.1 and 8.2.3.

Use this approximate result to obtain a more accurate value by reference to the calibration curve for the particular apparatus.

A calibration curve is supplied by the manufacturer of the apparatus. It shall be checked using reference materials.

## 10 Interpretation of results

The extreme heterogeneity and mobility of the lining of some articles can result in major variations in the measurements made. Experience has shown that the coefficient of variation can attain in some cases as much as 8 % and it is important to take this into account in the analysis of the results.

## 11 Test report

The test report shall state:

- a) that the procedure was conducted in accordance with this part of ISO 5085;
- b) a description of the sample tested;
- c) the thermal resistance, in square-metre kelvins per watt (m<sup>2</sup>·K/W);
- d) where applicable, the individual values calculated for the thermal resistance (see 8.2.2);
- e) the ambient conditions prevailing during the test (temperature in degrees Celsius, pressure and relative humidity);
- f) details of any operations not specified in this part of ISO 5085, together with details of any incidents liable to have affected the results.

ISO 5085-2:1990

<https://standards.iteh.ai/catalog/standards/sist/5d9cd009-3994-4bf5-aa09-b65e63e7a3c6/iso-5085-2-1990>

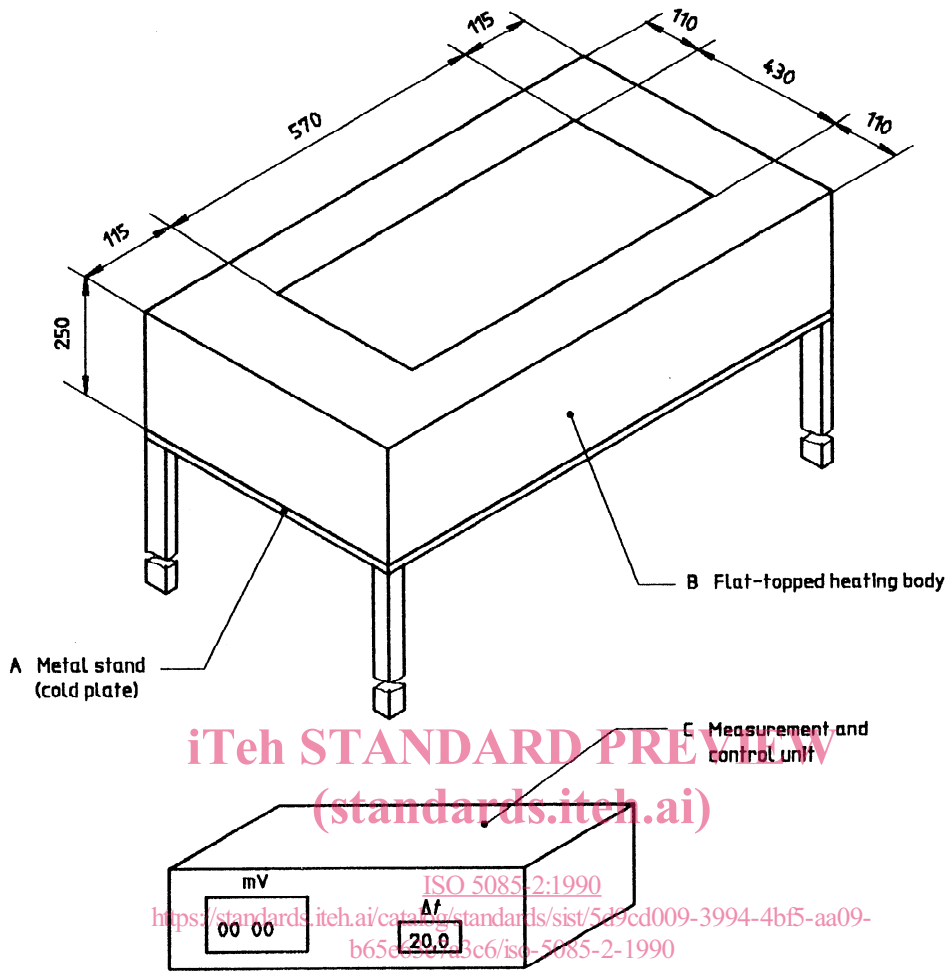

Figure 1 — Flat-topped heating body

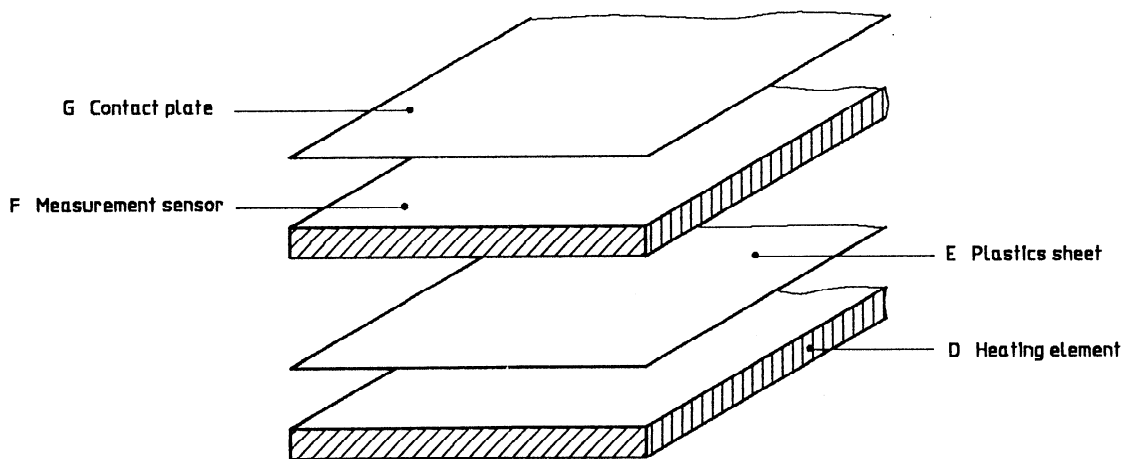

Figure 2 — Details of heating body



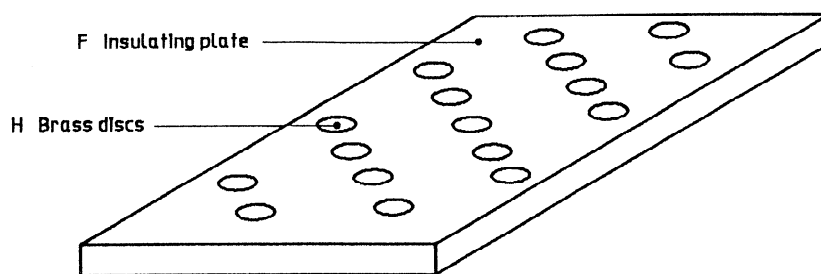

Figure 3 — Details of measurement sensor

---

**iTeh STANDARD PREVIEW**  
**(standards.iteh.ai)**

ISO 5085-2:1990

<https://standards.iteh.ai/catalog/standards/sist/5d9cd009-3994-4bf5-aa09-b65e63e7a3c6/iso-5085-2-1990>