



Designation: D7098 – 21

Standard Test Method for Oxidation Stability of Lubricants by Thin-Film Oxygen Uptake (TFOUT) Catalyst B^{1,2}

This standard is issued under the fixed designation D7098; the number immediately following the designation indicates the year of original adoption or, in the case of revision, the year of last revision. A number in parentheses indicates the year of last reappraisal. A superscript epsilon (ϵ) indicates an editorial change since the last revision or reappraisal.

1. Scope*

1.1 This test method covers the oxidation stability of lubricants by thin-film oxygen uptake (TFOUT) Catalyst B. This test method evaluates the oxidation stability of petroleum products, and it was originally developed as a screening test to indicate whether a given re-refined base stock could be formulated for use as automotive engine oil³ (see Test Method D4742). The test is run at 160 °C in a pressure vessel under oxygen pressure, and the sample contains a metal catalyst package, a fuel catalyst, and water to partially simulate oil conditions in an operating engine. In addition, the test method has since been found broadly useful as an oxidation test of petroleum products.⁴

1.2 The applicable range of the induction time is from a few minutes up to several hundred minutes or more. However, the range of induction times used for developing the precision statements in this test method was from 40 min to 280 min.

1.3 The values stated in SI units are to be regarded as standard. No other units of measurement are included in this standard.

1.3.1 *Exception*—Pressure units are provided in psig, and dimensions are provided in inches in **Annex A1** and **Annex A2**, because these are the industry accepted standard and the apparatus is built according to the figures shown.

¹ This test method is under the jurisdiction of ASTM Committee D02 on Petroleum Products, Liquid Fuels, and Lubricants and is the direct responsibility of Subcommittee D02.09.0G on Oxidation Testing of Engine Oils.

Current edition approved Oct. 1, 2021. Published November 2021. Originally approved in 2005. Last previous edition approved in 2015 as D7098 – 08 (2015). DOI: 10.1520/D7098-21.

² While Catalyst B can be used for testing oxidation stability of many lubricant types, the mixture of fuel, nitro-paraffin, and catalyst components used in this test method simulates the Sequence III-E Engine Test. Test results on several ASTM reference oils have been found to correlate with Sequence III-E engine tests in hours for a 375 % viscosity increase. (See Ku, Chia-Soon, Pei, Patrick T., and Hsu, Stephen M., “A Modified Thin-Film Oxygen Uptake Test (TFOUT) for the Evaluation of Lubricant Stability in ASTM Sequence III-E Test, SAE Technical Paper Series 902121, Tulsa, OK, Oct. 22-25, 1990.)

³ Ku, C. S. and Hsu, S. M., “A Thin Film Uptake Test for the Evaluation of Automotive Lubricants,” *Lubrication Engineering*, 40, 2, 1984, pp. 75–83.

⁴ Selby, Theodore W., “Oxidation Studies with a Modified Thin-Film Oxygen Uptake Test”, *SAE Technical Paper Series 872127*, Toronto, Ontario, Nov. 2-5, 1987.

1.4 *This standard does not purport to address all of the safety concerns, if any, associated with its use. It is the responsibility of the user of this standard to establish appropriate safety, health, and environmental practices and determine the applicability of regulatory limitations prior to use.*

1.5 *This international standard was developed in accordance with internationally recognized principles on standardization established in the Decision on Principles for the Development of International Standards, Guides and Recommendations issued by the World Trade Organization Technical Barriers to Trade (TBT) Committee.*

2. Referenced Documents

2.1 ASTM Standards:⁵

- A314 Specification for Stainless Steel Billets and Bars for Forging
- B211 Specification for Aluminum and Aluminum-Alloy Rolled or Cold-Finished Bar, Rod, and Wire (Metric) B0211_B0211M
- D664 Test Method for Acid Number of Petroleum Products by Potentiometric Titration
- D1193 Specification for Reagent Water
- D2272 Test Method for Oxidation Stability of Steam Turbine Oils by Rotating Pressure Vessel
- D4742 Test Method for Oxidation Stability of Gasoline Automotive Engine Oils by Thin-Film Oxygen Uptake (TFOUT)
- D7962 Practice for Determination of Minimum Immersion Depth and Assessment of Temperature Sensor Measurement Drift
- D8164 Guide for Digital Contact Thermometers for Petroleum Products, Liquid Fuels, and Lubricant Testing
- D8278 Specification for Digital Contact Thermometers for Test Methods Measuring Flow Properties of Fuels and Lubricants
- E1 Specification for ASTM Liquid-in-Glass Thermometers
- E144 Practice for Safe Use of Oxygen Combustion Vessels

⁵ For referenced ASTM standards, visit the ASTM website, www.astm.org, or contact ASTM Customer Service at service@astm.org. For *Annual Book of ASTM Standards* volume information, refer to the standard's Document Summary page on the ASTM website.

*A Summary of Changes section appears at the end of this standard

INDUCTION TIME DETERMINATION

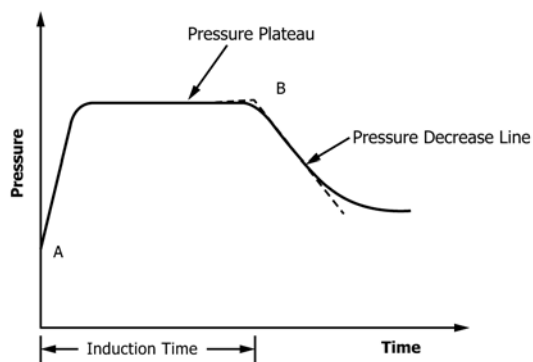

FIG. 1 Pressure versus Time Diagram of the Oxidation Test

3. Terminology

3.1 Definitions of Terms Specific to This Standard:

3.1.1 *break point, n*—the precise point of time at which rapid oxidation of the oil begins.

3.1.2 *oxidation induction time, n*—the time until the oil begins to oxidize at a relatively rapid rate as indicated by the decrease of oxygen pressure.

3.1.3 *oxygen uptake, n*—oxygen absorbed by oil as a result of oil oxidation.

4. Summary of Test Method

4.1 The test oil is mixed in a glass container with four other liquids used to simulate engine conditions: (1) an oxidized/nitrated fuel component (Annex A3), (2) a mixture of soluble metal naphthenates (lead, iron, manganese, and tin naphthenates (Annex A4), (3) a nitro-paraffinic compound, and (4) Type I reagent water.

4.2 The glass container holding the oil mixture is placed in a pressure vessel equipped with a pressure sensor. The pressure vessel is sealed, charged with oxygen to a pressure of 620 kPa (90 psig), and placed in an oil or dry bath at 160 °C at an angle of 30° from the horizontal. The pressure vessel is rotated axially at a speed of 100 r/min forming a thin film of oil within the glass container resulting in a relatively large oil-oxygen contact area.

4.3 The pressure of the pressure vessel is recorded continuously from the beginning of the test and the test is terminated when a rapid decrease of the pressure vessel pressure is observed (Point B, Fig. 1). The period of time that elapses between the time when the pressure vessel is placed in the oil or dry bath and the time at which the pressure begins to decrease rapidly is called the oxidation induction time and is used as a measure of the relative oil oxidation stability.

5. Significance and Use

5.1 This test method was originally developed to evaluate oxidation stability of lubricating base oils combined with additives chemistries similar to those found in gasoline engine oils and service.²

5.2 This test method is useful for screening formulated oils before engine tests. Within similar additive chemistries and base oil types, the ranking of oils in this test appears to be predictive of ranking in certain engine tests. When oils having different additive chemistries or base oil type are compared, results may or may not reflect results in engine tests. Only gasoline engine oils were used in generating the precision statements in this test method.

6. Apparatus

6.1 *Oxidation Bath and Pressure Vessel*—See appropriate Annex (Annex A1⁶ or Annex A2⁷) for detailed description of apparatus and accessories for equipment described in this test method.

NOTE 1—To reduce vapor odors when opening pressure vessel after use, a hood may be desirable.

6.2 *Precision Pressure Gauge*—Use a certified precision pressure gauge to accurately control the oxygen feed to the pressure vessel. The gauge shall have a sufficient range to encompass 0 kPa to 650 kPa (~90 psig) required by the test method with division 2.0 kPa (~0.5 psig) or better to enable readings to be made to 2.0 kPa (~0.25 psig).

6.3 *Thermometer*, digital (DCT) or liquid-in-glass styles shall be used to check the bath temperature monthly at a minimum. The thermometer shall be able to be read with an accuracy of ±0.1 °C at the level of 160 °C, such as D02-DCT-06 in Specification D8278. Thermometers, digital (DCT) or analog, need to be checked for accuracy at least one time per year. See Specification E1 and Practice D7962 for guidance.

7. Reagents

7.1 *Purity of Reagents*—Reagent grade chemicals shall be used in all tests. Unless otherwise indicated, it is intended that all reagents shall conform to the specifications of the Committee on Analytical Reagents of the American Chemical Society.⁸

7.2 *Purity of Water*—Unless otherwise indicated, references to reagent water shall be understood to mean distilled water meeting requirements of reagent water as defined by Type I of Specification D1193.

7.3 *Acetone*, CH₃COCH₃.

7.4 *Air*, containing 2000 ppm nitrogen dioxide, NO₂ (commercially available compressed gas mixture, certified within ±5 %).

⁶ The sole source of supply of the apparatus known to the committee at this time is Koehler Instrument Co., Inc., 1595 Sycamore Ave., Bohemia, NY11716 and Stanhope-Seta, London St., Chertsey, Surrey, KT16 8AP, U.K. If you are aware of alternative suppliers, please provide this information to ASTM International Headquarters. Your comments will receive careful consideration at a meeting of the responsible technical committee,¹ which you may attend.

⁷ The sole source of supply of the apparatus known to the committee at this time is Tannas Co., 4800 James Savage Rd., Midland, MI 48642. If you are aware of alternative suppliers, please provide this information to ASTM International Headquarters. Your comments will receive careful consideration at a meeting of the responsible technical committee,¹ which you may attend.

⁸ *ACS Reagent Chemicals, Specifications and Procedures for Reagents and Standard-Grade Reference Materials*, American Chemical Society, Washington, DC. For suggestions on the testing of reagents not listed by the American Chemical Society, see *Analar Standards for Laboratory Chemicals*, BDH Ltd., Poole, Dorset, U.K., and the *United States Pharmacopeia and National Formulary*, U.S. Pharmacopeial Convention, Inc. (USPC), Rockville, MD.

7.5 *Cyclo-hexane*, C_6H_{12} , Practical Grade or other suitable hydrocarbon solvent. (**Warning**—Highly flammable. Skin irritant on repeated contact. Aspiration hazard.)

7.6 *Isopropyl Alcohol*, $CH_3CH(CH_3)OH$.

7.7 *Oxygen*, 99.8 %.

8. Materials

8.1 TFOUT Catalyst B Package:⁷

8.1.1 *Fuel Component*—The fuel component is a nitrated gasoline fraction or organic equivalent. This component may be prepared in accordance with the procedures described in [Annex A3](#).

8.1.2 *Soluble Metal Catalyst Mixture*—This catalyst is a mixture of soluble metal catalysts (lead, iron, manganese, and tin). The catalyst may be prepared according to the procedures described in [Annex A4](#).

8.1.2.1 Other oxidation stability test methods have demonstrated that soluble metal catalyst supplies may be inconsistent and have significant effects on the test results. Thus, for test comparisons, the same source and same batch of metal naphthenates shall be used.

NOTE 2—It is good research practice to use the same batches of catalyst components when closely comparing engine oils.

NOTE 3—Slow, steady reactivity of some of the catalyst chemicals can be a problem. Such problems can be reduced by storing the closed catalyst vials in a refrigerator at approximately 5 °C. The catalyst chemicals remain effective up to six months after the septum is punctured, if they are stored as noted above.

8.1.3 *Nitro-paraffin*—This compound is made up of a nitri-alkane blend.

NOTE 4—Suitably prepared catalyst packages may be purchased from Tannas Co.⁷

8.2 *Varnish and Deposit Remover*, water-soluble varnish remover or other engine varnish/deposit removers.

8.3 *Silicone Stopcock Grease*.

9. Preparation of Apparatus

9.1 *Glass Sample Container*—A clean glass sample container is important for obtaining repeatable results. Thorough cleaning can be accomplished by (a) rinsing with cyclo-hexane or other suitable hydrocarbon solvent, (b) soaking in concentrated solution of a water-soluble varnish remover, (c) thoroughly rinsing with water, (d) rinsing with acetone, (e) and permitting to dry.

NOTE 5—A segmented glass reaction dish has been found suitable to prevent premature mixing of the catalyst components (see [Fig. A2.4](#))

9.2 *Cleaning of Pressure Vessel*—Fill with concentrated solution of a water-soluble varnish remover and soak for suitable time, rinse with water, rinse with acetone, and permit to dry.

9.3 *Cleaning of Pressure Vessel Stem*—Periodically disassemble, inspect, and clean the pressure vessel stem. Rinse the inside of the stem with isopropyl alcohol and blow dry with oil free compressed air. For users of apparatus described in [Annex A1](#), periodically insert a dry pipe cleaner into the transducer line opening for removal of potential residue buildup.

NOTE 6—Replace O-rings when reassembling the pressure transducers.

9.4 Periodically pressure test the pressure vessels at 690 kPa (~100 psi) with air or oxygen. If the pressure drops more than 0.690 kPa (~0.1 psi) on the pressure gauge within 60 s, replace the O-ring seals and inspect the valve seals according to manufacturer's directions. If the problem continues, contact the specific equipment manufacturer.

NOTE 7—Previous versions of this test method have called for hydrostatic testing of the pressure vessel. This was found unnecessary at the relatively low pressures involved in running this test method.

9.5 *Cleaning of Catalyst Syringes*—Use individual catalyst syringes for each catalyst component. Thoroughly clean and dry syringes prior to each use. (See [Annex A5](#) for recommended procedure.)

10. Procedure

10.1 *Weighing and Mixing Sample and Catalyst Components*:

10.1.1 Place the clean glass sample container onto the precision balance and tare.

10.1.2 Weigh $1.500\text{ g} \pm 0.001\text{ g}$ of oil sample into the container and tare.

10.1.3 Add $0.045\text{ g} \pm 0.001\text{ g}$ of the soluble metal catalyst mixture into the glass sample container and tare.

10.1.4 Add $0.030\text{ g} \pm 0.001\text{ g}$ each of the fuel component, nitro-paraffin and reagent water to the glass sample container and tare each time. It is easiest to add the distilled water last and place on top of the oil sample.

10.1.5 Just prior to inserting the glass sample container into the pressure vessel, thoroughly mix the catalyst components within the sample container by hand-rotation (approximately five rotations) and proceed immediately to [10.2](#). Delay may result in variation of results.

10.2 *Pressure Vessel Assembly and Charging*—Immediately and rapidly assemble and charge the pressure vessel in accordance with apparatus type (see [A1.2](#) or [A2.7](#)).

NOTE 8—Avoid releasing the oxygen too rapidly by decreasing the pressure to atmospheric in no less than 1 min to avoid possible foaming and overflow of the sample from the glass sample container.

10.3 *Oxidation*—Before starting the test, bring the heating bath to the test temperature at 160 °C and insert the pressure vessel(s) in accordance with apparatus type (see [A1.3](#) or [A2.8](#)).

10.3.1 Allow the bath temperature to level out at the test temperature, which must occur within 15 min after insertion of the pressure vessel. Maintaining the test temperature within the specified limits of $160\text{ °C} \pm 0.3\text{ °C}$ during the entire test run is the most important single factor ensuring both repeatability and reproducibility of test results. If the test temperature cannot be maintained as specified, the test results shall not be considered valid.

NOTE 9—The time for the bath to reach the operating temperature after insertion of the pressure vessel may differ for different apparatus assemblies and shall be observed for each unit (a unit may carry one, two, three, or four pressure vessels). The objective is to find a set of conditions, which does not permit a drop of more than 2 °C after insertion of the pressure vessel(s) and allows the pressure vessel pressure to reach plateau within 15 min.

10.4 Keep the pressure vessel completely submerged and maintain continuous and uniform rotation throughout the test.

A standard rotational speed of 100 r/min ± 5 r/min is required; any variation in this speed could cause erratic results.

10.5 Monitor the pressure of the pressure vessel preferably using a strip chart or some other form of electronic data collection program. If a dial pressure gauge is used, make readings at least every 5 min. (The maximum pressure must be reached within 15 min.) After a test period (the induction time), the pressure decreases because of oxygen absorption by oil (the break point).

10.5.1 When the oil reaches the break point, the pressure decreases rapidly as oxygen is absorbed rapidly by the test oil. The test can be terminated as soon as sufficient information has been collected to form a tangent to the decreasing pressure trace (see 10.6) or, if desired, continued until pressure decreases to some further level.

NOTE 10—The pressure within the pressure vessel increases at the beginning because of gas expansion accompanying the temperature increase of the pressure vessel. Following this rise, the pressure reaches a plateau as shown in Fig. 1. This pressure may gradually drop slightly during the test. A gradual decrease of the pressure is not unusual and does not invalidate the test. The time between initiating the test and the break point is called the oxidation induction time.

NOTE 11—If a break in pressure does not occur within 300 min to 500 min, the operator may elect to terminate the test. A slow decrease in pressure may also indicate a small leak from the pressure vessel, which is why it is a good practice to occasionally determine whether a slow leak is present.

10.6 Record the time at which the pressure starts to decrease rapidly at the break point (Point B, Fig. 1), which is marked as the intersection of the tangent of the pressure plateau line during the final 20 min before the break point and the tangent of the pressure decrease line following the break point as shown in Fig. 1.

11. Report

11.1 Report the oxidation induction time in minutes. Determine the induction time as the time period from the beginning of the test (Point A, Fig. 1) to the break point (Point B, Fig. 1).

12. Precision and Bias⁹

12.1 The precision of this test method, as determined by statistical examination of interlaboratory results on break point time, is as follows:

12.1.1 *Repeatability*—The difference between successive results, obtained by the same operator with the same apparatus under constant operating conditions on identical test material, would in the long run, in the normal and correct operation of the test method, exceed the following values only in one case in twenty:

14 % of mean

12.1.2 *Reproducibility*—The difference between two single and independent results obtained by different operators working in different laboratories on identical test material would, in the long run, in the normal and correct operation of the test method, exceed the following values only in one case in twenty:

39 % of mean

12.2 The range of induction times used for developing this precision statement was from 40 min to 280 min.

12.3 *Bias*—No information can be presented on the bias of the procedure in this test method for measuring oxidation stability because no material having an accepted reference value is available.

12.4 The precision statements in 12.1.1 and 12.1.2 were determined from an interlaboratory study using the same batch of soluble metal mixture (TFOUT Catalyst B Package of Tannas Co.).

13. Keywords

13.1 oxidation stability; sequence III E engine simulation; TFOUT

ASTM D7098-21

⁹ Supporting data have been filed at ASTM International Headquarters and may be obtained by requesting Research Report RR:D02-1571, including the raw data and the statistical treatment of data. Contact ASTM Customer Service at service@astm.org.

ANNEXES

(Mandatory Information)

A1. THIN FILM OXYGEN UPTAKE TEST USING THE RBOT/TFOUT APPARATUS

INTRODUCTION

Two types of TFOUT instruments were used in generating the precision data given in this test method. The first was the modified RBOT (now known as RPVOT) instrument originally used to develop the test procedure and for distinction is called the RBOT/TFOUT apparatus. The second was an instrument designed specifically to run the TFOUT test and later modified to permit running the RPVOT test.

NOTE A1.1—This annex utilizes two modified RPVOT (Test Method D2272) apparatus of similar design for running the TFOUT test. However,

strain-gauge pressure transducers and a computer were incorporated into the later version.

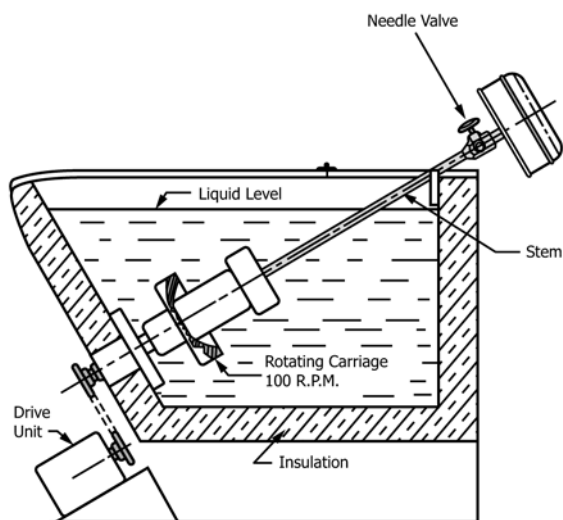

FIG. A1.1 Schematic Drawing of Oxidation Test Apparatus

A1.1 *Pressure Vessel*, with lid, cap, and stem is constructed as shown in Fig. A1.1. The pressure vessel has the same dimensional specifications as the RPVOT pressure vessel (see Test Method D2272). Therefore, the pressure vessel for RPVOT can be used for this test. However, in the test an aluminum insert and a glass sample container, as specified in A1.4 and A1.5, respectively, are to be used.³

A1.1.1 *Pressure Vessel Body and Lid*, are to be made of 303 stainless steel (see Specification A314). The pressure vessel body is to be machined from 76.2 mm (3.00 in.) solid stainless steel. The interior surface shall be given a smooth finish to facilitate cleaning.

A1.1.2 *Pressure Vessel Stem*, is to be constructed of 303 stainless steel, the stem having an inside diameter of 6.4 mm (0.25 in.) and is to be equipped with a 6.4 mm needle valve. The stem is connected to the center of the lid as shown in Fig. A1.3.

A1.1.3 *Pressure Vessel Cap (or Closure Ring)*, is to be made of chrome-plated steel.

A1.1.4 *O-ring Gaskets*, silicone or a fluorinated elastomer, 50.8 mm (2.00 in.) inside diameter by 60.3 mm (2.375 in.) outside diameter.

A1.2 *Pressure Vessel Assembly and Charging*—After proper cleaning (see Section 9), assemble the pressure vessel as shown in Fig. A1.2.

A1.2.1 Put the aluminum insert into the pressure vessel followed by the glass sample container and the TFE (tetrafluoro ethylene) plastic cover disk.

A1.2.2 Place the stainless hold-down spring on top of the TFE disk and the glass sample container.

NOTE A1.2—The stainless steel hold-down spring not only holds down the TFE cover disk but also, more importantly, prevents the glass sample container from slipping inside the pressure vessel with consequent poor results.

A1.2.3 Apply a thin coating of silicone stopcock grease to the O-ring high pressure vessel seal located in the gasket groove of the pressure vessel lid to provide lubrication.

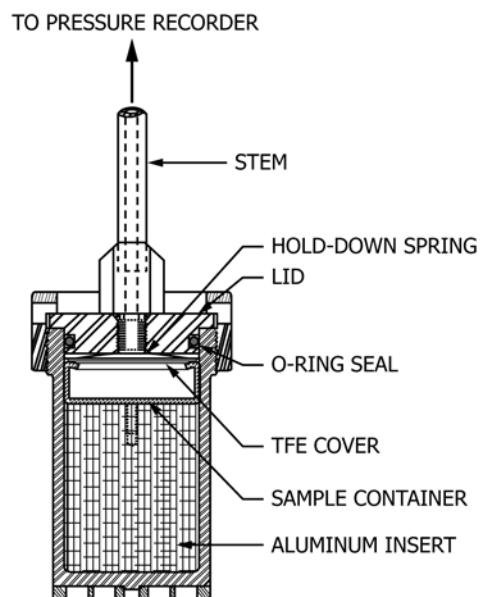

(HIGH PRESSURE REACTOR I.D. is 6.03 cm)

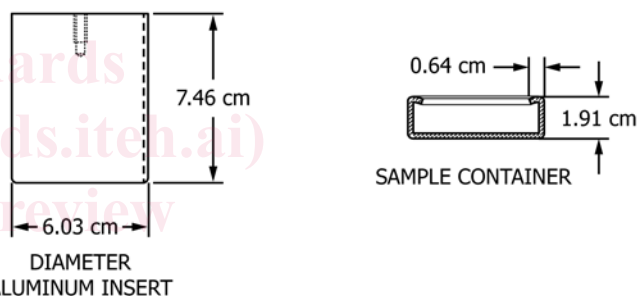

FIG. A1.2 Schematic Drawing of an Assembled Vessel, Aluminum Insert, and Glass Sample Container

A1.2.4 Insert the lid into the pressure vessel.

A1.2.5 Place and tighten the cap on the pressure vessel to lock down the lid in the pressure vessel.

A1.2.6 Attach the pressure oxygen hose and purge the pressure vessel twice at about 620 kPa (90 psig) of oxygen to remove the air originally present in the pressure vessel. (**Warning**—See Note 8.)

A1.2.7 Charge the pressure vessel to 620 kPa (90 psig) oxygen at 21 °C using an in-line precision pressure gauge to monitor the pressure vessel pressure with 1 kPa (0.12 psig). (For ambient temperatures other than 21 °C, increase (or decrease) the initial pressure by 2.5 kPa (0.4 psig) for each 1 °C above (or below) 21 °C.)

A1.2.8 Fill the pressure vessel to the required pressure and close the inlet valve. Test the pressure vessel for leaks by immersing in water or by using soap solution.

A1.2.9 Proceed to 10.3.

A1.3 *Oxidation*—Before starting the test, bring the heating bath to the test temperature of 160 °C while the stirrer is in

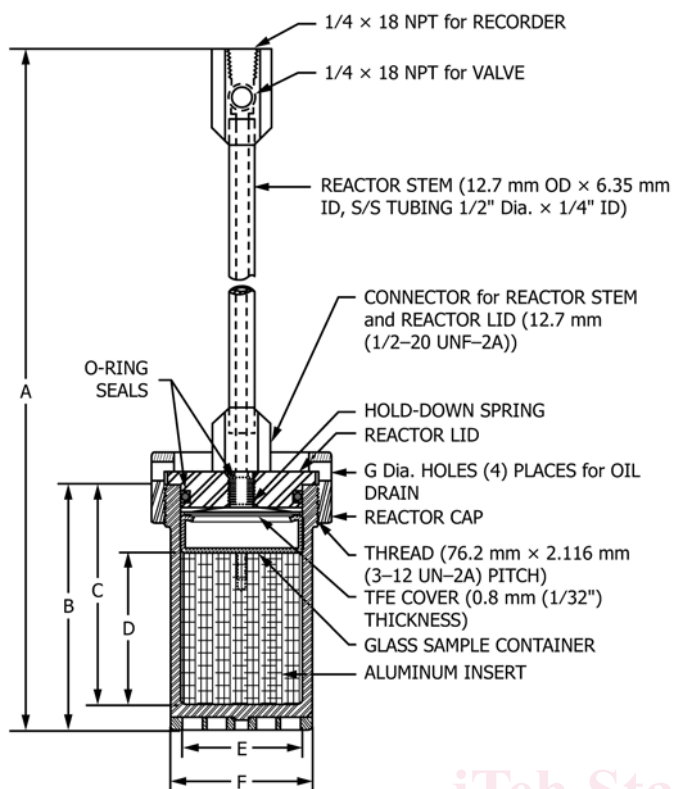

DIMENSIONS

	mm	in.
A	536	21.110
B	120.6	4.750
C	107.9	4.250
D	74.6	2.937
E	ø60.3/60.6	ø2.375 +.010/-0.000
F	ø69.8	ø2.750
G	ø9.5	ø.375

FIG. A1.3 Construction of Oxidation Vessel

operation. (This can be done during preparation of the sample and the pressure vessel.)

A1.3.1 Switch off the stirrer and insert the pressure vessel into the carriages. Note the time, and restart the stirrer.

A1.3.2 If an auxiliary heater is used, keep it on for the first 5 min of the run and then turn it off (Note 9).

A1.3.3 Proceed to 10.3.1.

A1.4 *Aluminum Insert*, (Fig. A1.2) made of 2024 aluminum rod (see Specification B211) with 60.3 mm in diameter and 74.6 mm in height.

A1.5 *Glass Sample Container*, (Fig. A1.2) constructed of borosilicate glass.

A1.5.1 The top of the sample container is to be covered with a 57.2 mm (2.25 in.) diameter TFE-fluorocarbon disk with a 3.2 mm (0.125 in.) diameter hole in the center. The TFE cover prevents sample splash during vessel charge. The disk shall have a thickness of 0.8 mm (0.03149 in.). As an added safeguard against the occurrence of rotational differences between the glass sample container and pressure vessel, a hold-down spring is required.

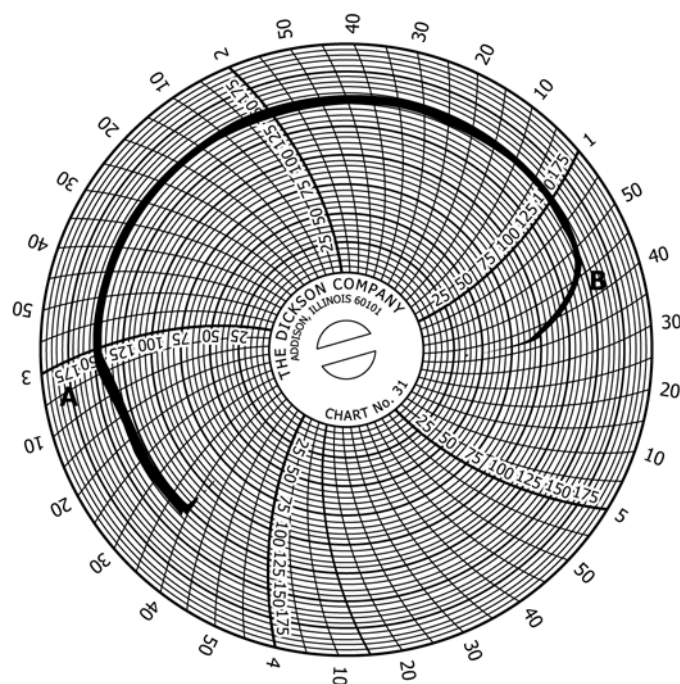

FIG. A1.4 Chart of Recording Pressure Gauge (Actual Size—144 mm (4½ in.))

A1.5.2 The glass sample container shall have a sliding fit in the pressure vessel with no excess side clearance. The container alone is to have a maximum wall thickness of 2.5 mm.

A1.6 *Gauge*, recording, as shown in Fig. A1.4, or indicating, with a range from 0 kPa to 1400 kPa (~200 psi) and graduated in 25 kPa (or 5 psi) divisions.

A1.6.1 The accuracy must be 2 % or less of the total scale interval.

A1.6.2 Mount recording gauges so that their faces are perpendicular to the axis of rotation.

NOTE A1.3—Clock-wound, round chart recorders shall be periodically checked for constancy of the clock works and agreement with standard time.

A1.7 *Oxidation Bath*, equipped with an efficient stirrer and with a suitable device for holding and rotating the pressure vessel axially at an angle of 30° at 100 r/min ± 5 r/min while submerged in oil to a point at least 25.4 mm (1 in.) below the level of the bath liquid (Note 2). Keep the oil level at 50.8 mm (2 in.) below the bath cover.

A1.7.1 A bath at least 229 mm (9 in.) deep, filled with 30 L (8 gal) of heavy bath oil per pressure vessel (petroleum or synthetic oil having a flash point greater than 250 °C). Dry bath technology is also available as shown in Test Methods D4742 and D2272; see manufacturer's manual for operational details.⁷

A1.7.2 Provide thermal regulation to maintain the bath within ±0.3 °C of the test temperature for a period as long as 8 h. There shall be sufficient heat immediately available to bring the high pressure vessels to operating temperature of 160 °C within 15 min.

A1.8 *Thermometer*, digital (DCT) or liquid-in-glass styles shall be used to check the bath temperature monthly at a minimum. The thermometer shall be able to be read with an accuracy of ± 0.1 °C at the level of 160 °C, such as D02-DCT-06 in Specification D8278. Thermometers, digital or

analog, need to be checked for accuracy at least one time per year. If using the ASTM Solvents Distillation 102C-86 thermometer, then use as prescribed in Specification E1 and Guide D8164.

A2. THIN FILM OXYGEN UPTAKE TEST USING THE DESIGNED TFOUT APPARATUS

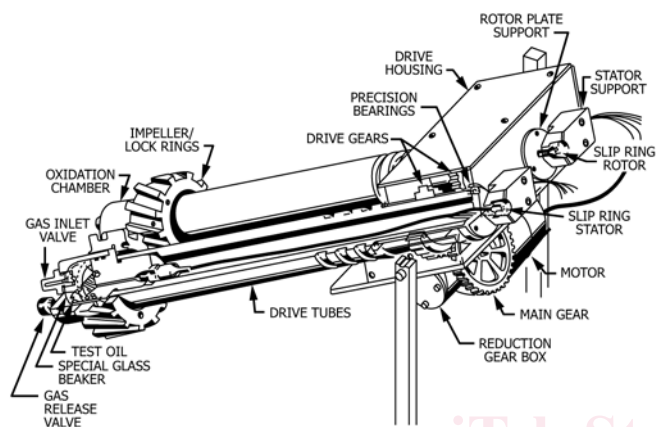

FIG. A2.1 Construction of Oxidation Vessel



FIG. A2.2 Photo of Reaction Vessel Body Assembly

A2.1 *Pressure Oxidation Vessel*, for the TFOUT apparatus is constructed as shown in Fig. A2.1. The TFOUT apparatus is designed to utilize the more sensitive strain-gauge technology and electronic amplification with a linear chart recorder or computer.

A2.2 *Oxidation Chamber*, is comprised of a reaction vessel cover and body constructed of highly polished 304 stainless steel. Dry bath technology is also available as shown in Test Methods D4742 and D2272; see manufacturer's manual for operational details.⁷

A2.2.1 *Reaction Vessel Body*, (Fig. A2.2), houses the reaction vessel cover and a special glass reaction dish and attaches to the drive tube. The vessel body measures 69.9 mm (2.75 in.) in diameter and 63.5 mm (2.5 in.) in length, with fittings for the gas inlet and gas outlet valves.

A2.2.2 *Reaction Vessel Cover*, (Fig. A2.3), protrudes from the reaction vessel body into the drive tube, with a 1/4-18 NPT drilled and tapped hole for connection with the pressure transducer fitting. Two O-rings, as specified in A2.5, are used for a pressure seal.

A2.3 *Drive Tube*, (Fig. A2.3), is to be constructed of 304 stainless steel, polished to a mirror-like finish, having an overall length of 493.3 mm (19.5 in.) and inside diameter of 39.7 mm (1.563 in.).

A2.4 *Impeller/Lock Ring*, (Fig. A2.3), is constructed of a highly polished 304 stainless steel with an outside diameter of 114.3 mm (4.5 in.) and thickness of 44.5 mm (1.75 in.),

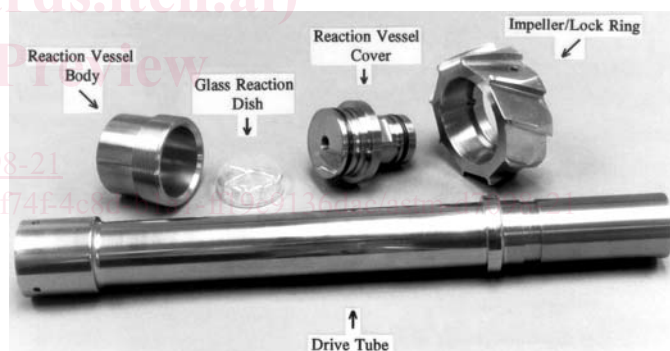

FIG. A2.3 Photo of High Pressure Vessel Components

equipped with nine 30° angle grooves utilized for stirring once the reactor is lowered into the bath. The impeller/lock ring fastens the reaction vessel body to the drive tube.

A2.5 *O-ring Gaskets*, silicone or a fluorinated elastomer, deterioration occurs over time.

A2.5.1 *Reaction Vessel O-ring*—Use two per reaction vessel cover, change after 50 runs (OD = 59.26 mm (2.33 in.)).

A2.5.2 *Gas Inlet O-ring*—Use one per gas inlet valve, change after two runs (OD = 14.29 mm (0.56 in.)).

A2.5.3 *Dual Valve O-ring*—Use one per gas inlet valve, change after 20 runs, and two per gas outlet valve, change after 50 runs (OD = 7.94 mm (0.31 in.)).