



Designation: **C1179–15** **C1179 – 21**

Standard Test Method for Oxidation Mass Loss of Manufactured Carbon and Graphite Materials in Air¹

This standard is issued under the fixed designation C1179; the number immediately following the designation indicates the year of original adoption or, in the case of revision, the year of last revision. A number in parentheses indicates the year of last reappraisal. A superscript epsilon (ϵ) indicates an editorial change since the last revision or reappraisal.

1. Scope*

1.1 This test method provides a comparative oxidation mass loss of manufactured carbon and graphite materials in air.

1.2 The values stated in SI units are to be regarded as standard. No other units of measurement are included in this standard.

1.3 *This standard does not purport to address all of the safety concerns, if any, associated with its use. It is the responsibility of the user of this standard to establish appropriate safety, health, and environmental practices and determine the applicability of regulatory limitations prior to use.*

1.4 *This international standard was developed in accordance with internationally recognized principles on standardization established in the Decision on Principles for the Development of International Standards, Guides and Recommendations issued by the World Trade Organization Technical Barriers to Trade (TBT) Committee.*

2. Summary of Test Method

2.1 The test method determines mass loss characteristics of carbon and graphite articles in air as a function of temperature and time by subjecting standard size specimens to muffle furnace exposure and then comparing pre-test and post-test mass differentials.

3. Significance and Use

3.1 This test method is primarily concerned with the oxidation mass loss of manufactured carbon and graphite materials in air at temperatures from 371 °C to 677 °C.

3.2 The test method will provide acceptable results at preselected test temperatures that yield less than 10 % mass loss in 100 h. These results can be used to determine relative service temperatures.

4. Interferences

4.1 Results can be affected by materials released by the furnace walls or furniture. These materials may be present from previous oxidation test samples or other furnace use. It is recommended that the furnace be operated at 1093 °C for 1 h prior to use for oxidation mass loss testing.

4.2 The validity of this test method depends upon the availability of oxygen to the test specimen. The door of the furnace shall be kept closed to maintain temperature control; however, the furnace door shall not be sealed, rendering the door airtight.

¹ This test method is under the jurisdiction of ASTM Committee D02 on Petroleum Products, Liquid Fuels, and Lubricants and is the direct responsibility of Subcommittee D02.F0 on Manufactured Carbon and Graphite Products.

Current edition approved Dec. 1, 2015; Nov. 1, 2021. Published January 2016; November 2021. Originally approved in 1991. Last previous edition approved in 2005; 2015 as C1179 – 91 (2010) 15. DOI: 10.1520/C1179-15.10.1520/C1179-21.

*A Summary of Changes section appears at the end of this standard

4.3 Due to factors beyond the scope of the test method that might cause significant differences, this test method is only useful for comparative results.

5. Apparatus

5.1 *Muffle Furnace*, with automatic temperature regulation with $\pm 4^{\circ}\text{C} \pm 4^{\circ}\text{C}$ precision. Furnace chamber volume 983 cm³ to 2458 cm³.

NOTE 1—Commercially available muffle furnaces advertised to achieve $\pm 11^{\circ}\text{C}$ can be set up to achieve the necessary precision.

5.2 *Thermocouple*, K-type (chromel/alumel with Type 304 stainless steel sheath).

5.3 *Digital Thermometer*, for temperature readout.

5.4 *Crucible Tongs*.

5.5 *Glazed Crucibles*, flat bottom.²

5.6 *Quart Glass Tray*, or equivalent.

5.7 *Nylon Gloves*, lint-free.

5.8 *Paper*, lint-free.

5.9 *Analytical Balance*, with 0.001 g resolution.

5.10 *Desiccator*, charged with indicating desiccant.

6. Sample Preparation

[ASTM C1179-21](https://standards.iteh.ai/catalog/standards/sist/16895afb-1337-46f3-82ce-edb3b66affe3/astm-c1179-21)

<https://standards.iteh.ai/catalog/standards/sist/16895afb-1337-46f3-82ce-edb3b66affe3/astm-c1179-21>

6.1 All specimens are to be handled with lint-free nylon gloves or equivalent during all machining, handling, impregnation, and testing. Specimens should be kept free of contamination by placing them on clean nonmetallic surfaces during all operations. Once the specimens have been oxidized, direct handling is not recommended.

6.2 Test specimens are to consist of right cylinders 25.4 mm diameter by 25.4 mm long ± 0.3 mm. Specimens are to be machined all over with carbide-tipped tools to achieve a surface roughness visually comparable to ~~0.8 μm~~ 0.8 μm arithmetic average (AA).

6.3 Wipe specimens with lint-free paper to remove carbon machining dust.

6.4 Specimens and crucibles are to be clearly identified. To avoid sample contamination, use a carbide-tipped scribe to mark the specimens. Crucibles can be marked with ceramic ink.

6.5 Place each specimen to be tested on its side (cylindrical surface) in a dried, tared crucible. Specimens are to be kept in the same crucible for the test duration. Record the individual identification numbers for each specimen/crucible set.

6.6 Dry the specimen/crucible sets in a vented oven at 120 °C to 150 °C for a minimum of 2 h. Remove the specimen/crucible sets and cool in a desiccator for a minimum of 30 min to achieve room temperature.

² The sole source of supply of the crucible (Coors crucible 60048) known to the committee at this time is Coors Ceramics Co., 17750 W. 32nd Ave., Golden, CO 80401. If you are aware of alternative suppliers, please provide this information to ASTM International Headquarters. Your comments will receive careful consideration at a meeting of the responsible technical committee,¹ which you may attend.

7. Procedure

7.1 Before the running of this test method, the operator should practice the transferring of similar shaped specimens from furnace to desiccator. The specimen/crucible set should be transferred so that the specimen is exposed to the atmosphere for no longer than 30 s. The desiccator should be in the immediate vicinity of the furnace.

7.2 Preheat and stabilize the furnace to the designated test temperature as verified by a monitoring thermocouple extending 50 mm into the chamber from the rear furnace wall (see Fig. 1).

7.3 Just before testing, remove the specimen/crucible sets from the desiccator and immediately weigh on an analytical balance to the nearest 0.001 g. Record this data as pretest mass.

7.4 Place two preweighed replicate specimen/crucible sets on a quartz glass tray or equivalent and insert into the furnace chamber so that the monitoring thermocouple is approximately centered between the specimens. Specimens are to be 25 mm ± 6 mm apart and centered on the monitoring thermocouple (see Fig. 1).

7.5 Monitor the thermocouple reading and maintain furnace chamber temperature within ±4 °C of the designated test temperature. Record the temperature readings from the monitoring thermocouple on the data sheet for the following times for each test period:

7.5.1 Just before inserting samples into furnace,

7.5.2 1 h after start, and

7.5.3 Just before removing samples for weighing.

7.6 Remove the specimen/crucible sets from the furnace every 25 h ± 1 h, for a total test time of 100 h, ±15 min. Cool in a desiccator for a minimum of 30 min. Weigh the specimen/crucible set on an analytical balance to the nearest 0.001 g and record data as post-test mass for the specific test time interval at the designated test temperature.

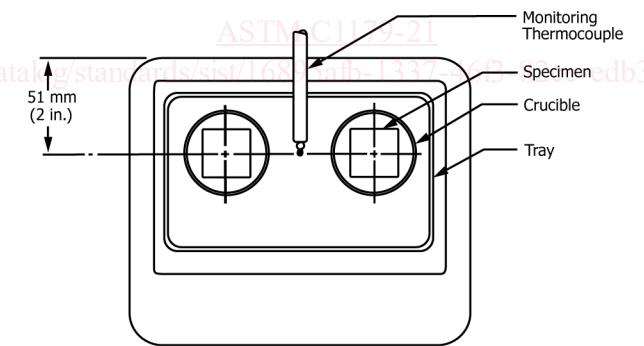

(a) Furnace Chamber—Top View

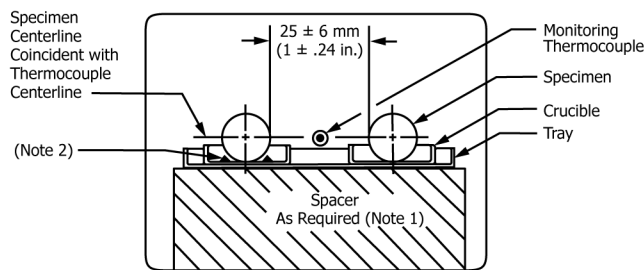

(b) Furnace Chamber—Cross Section View

NOTE 1—A medium weight insulating firebrick has been found to be satisfactory for this purpose.

NOTE 2—Small wedges of ceramic (broken) crucible pieces can be used to hold samples in place.

FIG. 1 Views of Furnace Chamber