



Designation: E1945 – 21

Standard Test Method for Percent Dispersibility¹

This standard is issued under the fixed designation E1945; the number immediately following the designation indicates the year of original adoption or, in the case of revision, the year of last revision. A number in parentheses indicates the year of last reapproval. A superscript epsilon (ϵ) indicates an editorial change since the last revision or reapproval.

1. Scope

1.1 This test method is used to determine the percent dispersibility of dry pesticide formulations.

1.2 The values stated in SI units are to be regarded as standard. No other units of measurement are included in this standard.

1.3 *This standard does not purport to address all of the safety concerns, if any, associated with its use. It is the responsibility of the user of this standard to establish appropriate safety, health, and environmental practices and determine the applicability of regulatory limitations prior to use.* For specific precautionary statements see Section 7.

1.4 *This international standard was developed in accordance with internationally recognized principles on standardization established in the Decision on Principles for the Development of International Standards, Guides and Recommendations issued by the World Trade Organization Technical Barriers to Trade (TBT) Committee.*

2. Referenced Documents

2.1 *ASTM Standards:*²

D1126 Test Method for Hardness in Water

D1193 Specification for Reagent Water

3. Summary of Test Method

3.1 A known amount of dry pesticide formulation is added to a 250 mL mixing cylinder that has been filled to volume with standard water. The mixing cylinder is then stoppered and inverted 30 times in 2 min. The mixing cylinder is allowed to stand for 1 min. After 1 min, the top 225 mL is drawn off and the remaining suspension is dried. The residue weight will determine percent dispersibility.

¹ This test method is under the jurisdiction of ASTM Committee E35 on Pesticides, Antimicrobials, and Alternative Control Agents and is direct responsibility of Subcommittee E35.22 on Pesticide Formulations and Delivery Systems

Current edition approved Oct. 1, 2021. Published November 2021. Originally approved in 1998. Last previous edition approved in 2016 as E1945 – 02(2016). DOI: 10.1520/E1945-21.

² For referenced ASTM standards, visit the ASTM website, www.astm.org, or contact ASTM Customer Service at service@astm.org. For *Annual Book of ASTM Standards* volume information, refer to the standard's Document Summary page on the ASTM website.

4. Significance and Use

4.1 This test method is designed specifically for dry formulations.

4.2 This test method may not be applicable to all dry formulations such as those containing water soluble or liquid technicals/pesticides or ingredients that rise to the top upon separation.

4.3 This test method may not be applicable to those technicals that decompose below the drying temperature.

4.4 This test method should be run in duplicate.

4.5 Products containing water soluble or volatile components may result in errors.

5. Apparatus

5.1 *Balance*, top loading, with an accuracy of ± 0.01 g or better.

5.2 *Gravity Oven*.

5.3 *Weighing Dish*, 150 mL capacity or greater.

5.4 *Vacuum Apparatus*, see Fig. 1, equipped with a vented stopper.

5.5 *Mixing Cylinder*, stoppered, 250 mL, flat bottom.

5.6 *Timer*, adjustable, with an accuracy of ± 1 s.

5.7 *Weighing Dish*, aluminum (57 \times 18 mm) or petri dish or equivalent.

5.8 *Filtering Flask*, heavy wall, 500 mL.

6. Reagents (Test Water)

6.1 *Purity of Reagents*—Reagent grade chemicals shall be used in all tests. Unless otherwise indicated, it is intended that all reagents shall conform to the specifications of the Committee on Analytical Reagents of the American Chemical Society where such specifications are available.³

³ *Reagent Chemicals, American Chemical Society Specifications*, American Chemical Society, Washington, DC. For Suggestions on the testing of reagents not listed by the American Chemical Society, see *Annual Standards for Laboratory Chemicals*, BDH Ltd., Poole, Dorset, U.K., and the *United States Pharmacopeia and National Formulary*, U.S. Pharmacopeial Convention, Inc. (USPC), Rockville, MD.

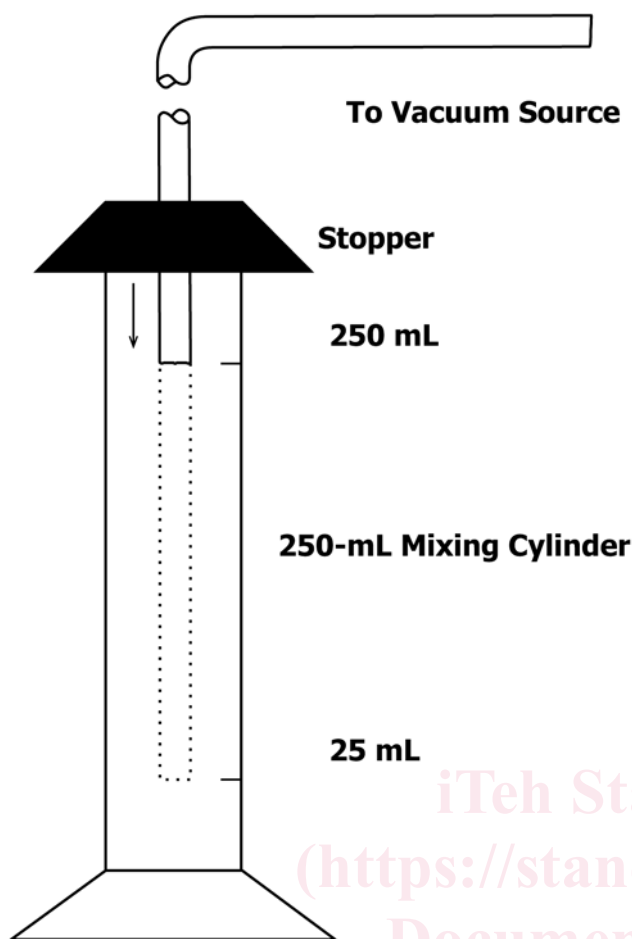

FIG. 1 Vacuum Apparatus

6.2 *Purity of Water*—Unless otherwise indicated, reference to water shall be understood to mean reagent water, Type IV, as defined by Specification D1193.

NOTE 1—Type IV grade reagent water may be prepared by distillation, ion exchange, reverse osmosis, electrodialysis, or a combination thereof.

6.3 *Synthetic Hard Water Stock*, transfer 12.14 g of anhydrous calcium chloride (CaCl_2) and 5.55 g of magnesium chloride hexahydrate ($\text{MgCl}_2 \cdot 6\text{H}_2\text{O}$) to a 1000 mL volumetric flask. Dissolve the reagents with approximately 750 mL of water and equilibrate to 20 °C. Dilute the solution to 1000 mL total volume with water at 20 °C, stopper the flask, and mix the solution thoroughly. This mixture is equivalent to 13 680 ppm as calcium carbonate (CaCO_3) and is based on a compositional ratio of 4:1 calcium carbonate to magnesium carbonate.

6.3.1 *Soft Water*, equivalent to a total hardness of 34.2 ppm as calcium carbonate (CaCO_3). Transfer 2.50 mL of synthetic hard water stock by pipet to a 1000 mL volumetric flask. Dilute to the 1000 mL mark with water at 20 °C. Mix solution thoroughly.

NOTE 2—It is recommended that total hardness be checked in accordance with Test Method MT-73, CIPAC 1, EDTA titration.⁴ An alternate

method is provided in Test Method D1126 where the value is represented as CaCO_3 . A value within $\pm 5\%$ of the nominal hardness value is acceptable.

6.3.2 *Hard Water*, equivalent to a total hardness of 342 ppm as calcium carbonate (CaCO_3). Transfer 25.0 mL of synthetic hard water stock by buret to a 1000 mL volumetric flask. Dilute to the 1000 mL mark with water at 20 °C. Mix this solution thoroughly (see Note 2).

6.3.3 *Extra-hard Water*, equivalent to a total hardness of 1000 ppm as calcium carbonate (CaCO_3). Transfer 73.1 mL of synthetic hard water stock by buret to a 1000 mL volumetric flask. Dilute to the 1000 mL mark with water at 20 °C. Mix this solution thoroughly (see Note 2).

6.3.4 *Other Test Waters*—Other synthetic waters can be prepared by using the following calculation:

$$\begin{aligned} \text{Desired Water Hardness} &= 13.680 = & (1) \\ & [\text{milliliters of synthetic} \\ & \text{hard water stock at } 20^\circ\text{C to be} \\ & \text{diluted volumetrically to 1000 mL} \\ & \text{with water at } 20^\circ\text{C}]. \end{aligned}$$

6.4 *Other Carriers*—Carriers other than water may be used when appropriate.

7. Safety Precautions

7.1 Before testing, read the precautionary statements on the product label or the Safety Data Sheet (SDS), or both. Take proper precautions to prevent skin contact and inhalation of the fines or vapors, or both. Take care to prevent contamination of the surrounding area. Always wear the appropriate safety equipment and, where indicated, wear respiratory devices approved by the National Institute of Occupational Safety and Health (NIOSH) for the product being tested.

8. Procedure

8.1 Each sample should be run in duplicate.

8.1.1 Weigh a 2.5 g sample into a weighing dish. Record the sample weight (W_1) to an accuracy of ± 0.01 g.

8.1.2 Fill a 250 mL mixing cylinder to volume with test water and equilibrate to $20^\circ\text{C} \pm 2^\circ\text{C}$, (see Note 3).

NOTE 3—Other temperatures may be examined as defined by actual field use applications.

8.1.3 Transfer the sample from 8.1.1 to the mixing cylinder.

8.1.4 Stopper and invert the cylinder 30 times in two minutes.

8.1.5 Let the mixing cylinders stand for 1 min.

8.1.6 Remove 225 mL from the mixing cylinder using the vacuum apparatus in accordance with Section 5.4. Ensure that the tip of the suction tube remains slightly below the liquid surface while removing the 225 mL. Take care not to disturb the bottom 25 mL layer.

8.1.7 Record the tare weight of the weighing dish to an accuracy of ± 0.01 g.

8.1.8 Gently swirl the remaining suspension to loosen the hard-packed material. Transfer quantitatively to the weighing dish. Rinse the cylinder with additional test water if necessary.

⁴ "Physico-Chemical Methods for Technical and Formulated Pesticides," CIPAC Handbook, Vvol F, compiled by W. Dorbat and A. Martin, Collaborative International Pesticide Analytical Council Ltd., Great Britain, 1995.