



Designation: ~~D7940~~—14 D7940 – 21

## Standard Practice for Analysis of Liquefied Natural Gas (LNG) by Fiber-Coupled Raman Spectroscopy<sup>1</sup>

This standard is issued under the fixed designation D7940; the number immediately following the designation indicates the year of original adoption or, in the case of revision, the year of last revision. A number in parentheses indicates the year of last reappraisal. A superscript epsilon ( $\epsilon$ ) indicates an editorial change since the last revision or reappraisal.

### 1. Scope

1.1 This ~~standard~~ practice is for both on-line and laboratory instrument-based determination of composition for liquefied natural gas (LNG) using Raman spectroscopy. ~~The~~ Although the procedures in this practice refer specifically to liquids, the basic methodology can also be applied to other light hydrocarbon mixtures in either liquid or gaseous states, ~~if the needs of the application are met, although the rest of this practice refers specifically to liquids, provided the data quality objectives and measurement needs are met.~~ From the composition, gas properties such as heating value and the Wobbe index may be calculated. The components commonly determined according to this test method are CH<sub>4</sub>, C<sub>2</sub>H<sub>6</sub>, C<sub>3</sub>H<sub>8</sub>, i-C<sub>4</sub>H<sub>10</sub>, n-C<sub>4</sub>H<sub>10</sub>, iC<sub>5</sub>H<sub>12</sub>, n-C<sub>5</sub>H<sub>12</sub>; ~~neo-C<sub>5</sub>H<sub>12</sub>, N<sub>2</sub>, O<sub>2</sub>.~~ The applicable range of this standard is 200 ppmv to 100 mol %. Components heavier than C5 are not measured as part of this practice.

NOTE 1—Raman spectroscopy does not directly quantify the component percentages of noble ~~gases; gases;~~ however, ~~inerts~~ inert substances can be calculated indirectly by subtracting the sum of the other species from ~~100 %; 100 %.~~

1.2 ~~Units~~—The values stated in SI units are to be regarded as standard. No other units of measurement are included in this standard.

1.3 ~~This standard does not purport to address all of the safety concerns, if any, associated with its use. It is the responsibility of the user of this standard to establish appropriate safety, health, and environmental practices and determine the applicability of regulatory limitations prior to use.~~

1.4 ~~This international standard was developed in accordance with internationally recognized principles on standardization established in the Decision on Principles for the Development of International Standards, Guides and Recommendations issued by the World Trade Organization Technical Barriers to Trade (TBT) Committee.~~

### 2. Referenced Documents

#### 2.1 ASTM Standards:<sup>2</sup>

- ~~D3588 Practice for Calculating Heat Value, Compressibility Factor, and Relative Density of Gaseous Fuels~~
- ~~D4150 Terminology Relating to Gaseous Fuels~~
- ~~E691 Practice for Conducting an Interlaboratory Study to Determine the Precision of a Test Method~~
- ~~D1945 Test Method for Analysis of Natural Gas by Gas Chromatography~~
- ~~D1946 Practice for Analysis of Reformulated Gas by Gas Chromatography~~
- ~~D3588 Practice for Calculating Heat Value, Compressibility Factor, and Relative Density of Gaseous Fuels~~

<sup>1</sup> This ~~test method~~ practice is under the jurisdiction of ASTM Committee D03 on Gaseous Fuels and is the direct responsibility of Subcommittee D03.12 on On-Line/At-Line Analysis of Gaseous Fuels.

Current edition approved ~~June 1, 2014~~ Nov. 1, 2021. Published ~~July 2014~~ November 2021. Originally approved in 2014. Last previous edition approved in 2014 as D7940 – 14. DOI: ~~10.1520/D7940-14~~ 10.1520/D7940-21.

<sup>2</sup> For referenced ASTM standards, visit the ASTM website, www.astm.org, or contact ASTM Customer Service at service@astm.org. For Annual Book of ASTM Standards volume information, refer to the standard's Document Summary page on the ASTM website.

[D4150 Terminology Relating to Gaseous Fuels](#)

[D7833 Test Method for Determination of Hydrocarbons and Non-Hydrocarbon Gases in Gaseous Mixtures by Gas Chromatography](#)

[E691 Practice for Conducting an Interlaboratory Study to Determine the Precision of a Test Method](#)

2.2 *BS EN Standards*.<sup>3</sup>

[BS EN 60079-28 Explosive Atmospheres. Protection of Equipment and Transmission Systems using Optical Radiation](#)

[BS EN 60825-1 Safety of Laser Products Part 1: Equipment Classification, Requirements and User's Guide](#)

2.3 *ISO Standards*.<sup>4</sup>

[ISO 6974-5 Natural Gas—Determination of Composition with Defined Uncertainty by Gas Chromatography, Part 5: Determination of nitrogen, carbon dioxide Nitrogen, Carbon Dioxide and C1 to C5 and C6+ hydrocarbons Hydrocarbons for a laboratory and on-line process application using three columns Laboratory and On-line Process Application Using Three Columns](#)

[ISO 6976:2016\(E\) Natural Gas—Calculation of Calorific Values, Density, Relative Density and Wobbe Indices from Composition](#)

### 3. Terminology

3.1 *Definitions*: ~~Refer to~~ For definitions ~~D4150~~ for definitions related to gaseous fuels of general terms used in D03 Gaseous Fuels standards, refer to Terminology [D4150](#).

3.2 *Definitions of Terms Specific to This Standard*:

3.2.1 ~~Accumulations, accumulations, n—while the exposure time is optimized to control the amount of light entering the camera for a single exposure, multiple exposures can be co-added to improve signal-to-noise. The~~ the number of exposures co-added are referred to as accumulations.

3.2.1.1 *Discussion*—

While the exposure time is optimized to control the amount of light entering the instrument for a single exposure, multiple exposures can be co-added to improve signal-to-noise.

3.2.2 ~~charge-coupled device, device (CCD), n—silicon based two dimensional light sensor characterized by possessing a grid of potential energy wells where light-generated free electrons collect and then are read out sequentially.~~

3.2.3 ~~charge-coupled device (CCD) binning, v—process of combining “bins” or pixel wells on the CCD.~~

3.2.4 ~~Exposure Time, exposure time, n—the CCD converts photons to electrons over time for a measurement. The exposure time indicates the amount of time allocated for capturing photons. The number of electrons is counted at the end of the allotted exposure time via a binning process.~~

3.2.4.1 *Discussion*—

The number of electrons is counted at the end of the allotted exposure time via a binning process. The CCD converts photons to electrons over time for a measurement.

3.2.5 ~~incident light,  $\lambda_i$ , n—monochromatic light illuminated into sample.~~

3.2.6 ~~Raman Scattering Effect, scattering effect, n—an energy transfer process between photons and molecules. In this photon-molecule interaction, scattered light has a different wavelength compared to the incident wavelength. The Raman wavelength shift spectrum is unique for each molecule because the shift is dependent upon the molecular bonding structures.~~

3.2.6.1 *Discussion*—

In this photon-molecule interaction, scattered light has a different wavelength compared to the incident wavelength. The Raman wavelength shift spectrum is unique for each molecule because the shift is dependent upon the molecular bonding structures.

3.2.7 ~~Raman spectroscopy, n—a type of molecular vibration spectroscopy in which a laser is used to excite virtual energy states in the molecules being illuminated, which then decay, producing new photons that are the sum and difference between the laser and the vibrational frequencies. These new photons are then collected and analyzed to determine the vibrational spectrum of the molecules.~~

3.2.7.1 *Discussion*—

These new photons are then collected and analyzed to determine the vibrational spectrum of the molecules.

<sup>3</sup> Available from British Standards Institution (BSI), 389 Chiswick High Rd., London W4 4AL, U.K., <http://www.bsigroup.com>.

<sup>4</sup> Available from International Organization for Standardization (ISO), 1, ch. de la Voie-Creuse, CP 56, CH-1211 Geneva 20, Switzerland, <http://www.iso.org>.

3.2.8 *Raman spectrum,  $n$* —plot of intensity against Raman wavelength shift.

3.2.9 *scattered light,  $\lambda_s = \lambda_s, n$* —scattered light as a result of the Raman scattering effect.

3.2.10 *signal strength,  $n$* —a measure of the amount of Raman-scattered photons reaching the CCD. Usually some scaled combination of raw areas of peaks from compounds expected to be present in LNG.

3.2.10.1 Discussion—

Usually some scaled combination of raw areas of peaks from compounds expected to be present in LNG.

3.2.11 *wavenumber,  $k$  or  $\nu, [cm^{-1}]$ ,  $n$* —abbreviated as  $cm^{-1}$ ; method of specifying the wavelength of optical radiation. Raman bands are constant wavenumber shifts from the excitation source independent of the wavelength of that source. number of waves per unit length of optical radiation.

3.2.11.1 Discussion—

Raman bands are constant wavenumber shifts from the excitation source independent of the wavelength of that source.

3.3 Acronyms:

3.3.1 *CCD*—charge coupled device

3.3.2 *IS*—industry standard

3.3.3 *NIST*—National Institute of Standards and Technology

3.3.4 *NMI*—National Metrology Institute

3.3.5 *OH*—hydroxyl groups

3.4 Acronyms: Abbreviations:

3.4.1 *GC*—Gas chromatograph

3.4.2 *GHV*—Gross Heating Value heating value

<https://standards.iteh.ai/catalog/standards/sist/6c3af6b7-25e3-4589-8ccc-b46616875ffc/astm-d7940-21>

3.4.3 *LNG*—Liquefied natural gas

3.4.4 *LPG*—Liquefied petroleum gas

3.3.5 *NIST*—National Institute of Standards and Technology

3.5 Symbols:

3.5.1  *$\lambda_i$* —incident light

3.5.2  *$\lambda_s$* —scatter light

3.5.3  *$k$* —coverage factor for confidence interval

**4. Summary of Practice**

4.1 Measurement of the volume fractions of individual molecular species contained in a liquid stream of interest such as LNG is accomplished by obtaining and analyzing Raman spectra (Fig. 1). Monochromatic light from a laser is directed down a fiber-optic cable through a sample-compatible probe-optic probe and into the liquid to be measured. Monochromatic photons interact with the molecules of the liquid via the Raman effect to produce new photons whose wavelengths have been shifted in proportion to vibration frequencies of the molecules. These new, shifted photons are collected through the same optics that delivered the original monochromatic light and are directed down a separate fiber that is connected to a detection module. The detection module contains a spectrograph, which directs photons of different wavelengths to different pixels on a CCD detector. The CCD pixels integrate

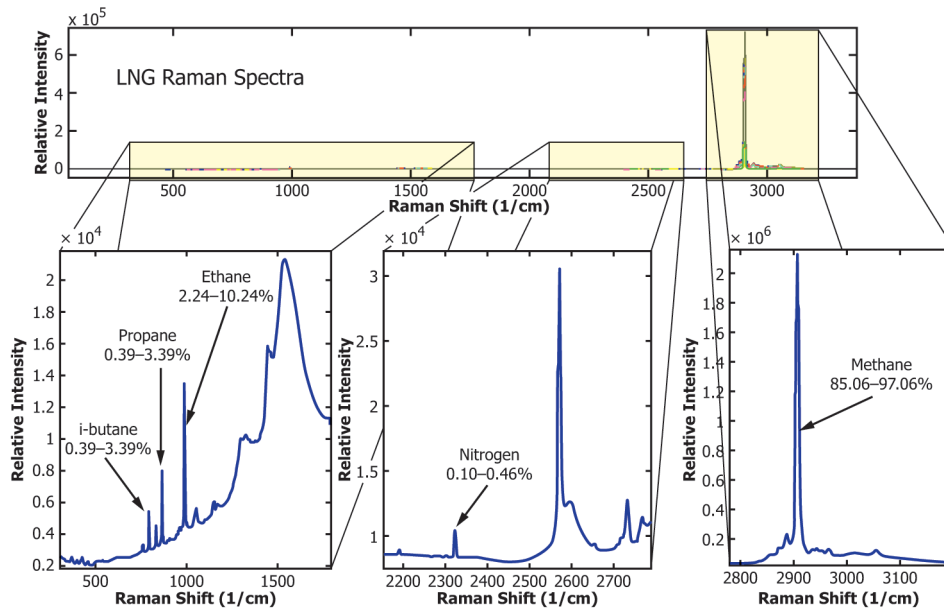

FIG. 1 LNG Raman Spectra

the photons falling on them into a digital signal, whose value is proportional to the number of photons. Thus, a spectrum is produced, representing a histogram charting the number of photons detected at each wavelength, corresponding to the number of molecules with particular ~~vibration~~vibrational frequencies. The spectra can be mathematically processed to yield the molecular composition of the liquid. Using standards such as Practice D3588, the energy content, and indices such as the Wobbe index, can be calculated from the composition information.

## 5. Significance and Use

5.1 The composition of liquefied ~~gaseous~~gaseous fuels (LNG, LPG) is important for custody transfer and production. Compositional determination is used to calculate the heating value, and it is important to ensure regulatory compliance. Compositional determination is also used to optimize the efficiency of liquefied hydrocarbon gas production and ensure the quality of the processed fluids.

5.2 Alternatives to compositional measurement using Raman spectroscopy are described in Test Method D1945, Practice D1946, and Test Method D7833.

5.3 The advantage of this ~~standard practice~~standard practice over ~~existing other standards mentioned~~existing other standards mentioned stated in 5.2 ~~above~~above, is that Raman spectroscopy can determine composition by directly measuring the liquefied natural gas. Unlike chromatography, no vaporization step is necessary. Since incorrect operation of on-line vaporizers can lead to poor precision and accuracy, elimination of the vaporization step offers a significant improvement in the analysis of LNG.

## 6. Interferences

6.1 Cosmic rays may be detected by the CCD, thus interfering with the Raman spectrum. Typically, a data collection process ~~and~~and algorithm is used to eliminate this ~~consideration~~interference. Spectra are taken in pairs and mathematically compared to each other to determine if a cosmic ray has excited specific pixels, which can then be excised from the data ~~set~~set.

6.2 Thermally generated electrons add to the true scatter spectrum. This effect is minimized by detector design and manufacturing as well as cooling, and with subtraction of the remaining thermal background is subtracted background.

6.3 ~~The standard~~This practice is intended for sample locations where the sample phase is entirely liquid. Mixed-phase (gas and liquid) or the presence of a significant amount of bubbles due to insufficient insulation or cavitation may impact the precision and accuracy.

7. Apparatus

7.1 Analyzer Base Unit (Fig. 2)—The base unit contains the electrically powered system components including the laser with associated safety devices, detection module, control electronics, data communication equipment, human/machine interface, and environmental control equipment. This is typically mounted inside an enclosure suitable for the installation site.

7.1.1 Laser—Generates monochromatic light for the creation of a Raman signal within the sample. To be effective, the laser shall have a narrow-enough line width with a stable-enough power output and wavelength so as not to compromise the generation and analysis of the Raman spectra. The wavelength of the laser must match the design specifications of the detector module such that the Raman photons produced are in the wavelength range that the detector module can detect. In addition, the laser photons and Raman photons must be of such a wavelength that they can be transmitted through a fiber-optic cable with minimal attenuation. Generally, a laser of wavelength ~~785 nm~~ 785 nm has been found to work well, but other lasers in the range of 500 to 800 nm may also be possible, provided the detector is chosen appropriately. The laser shall also have features that make it compatible with both explosive atmosphere safety (see EN60079-28) as well as eye safety (see EN 60825-1). This will generally include a remote-capable power-interlocking system, a redundant power-monitoring system, and a visible operation indicator light system. Typical performance values meet these criteria:

7.1.1.1 Power stability  $\pm 5\%$  long term over operating temperature range (0 to 45 °C),

7.1.1.2 Line width  $\leq 1 \text{ cm}^{-1}$ , and

7.1.1.3 Wavelength stability 0.005 nm short term (several minutes) and 0.05 nm long term (years).

7.1.2 ~~Detection Module~~ Detection Module

7.1.2.1 Spectrograph—Optical device for separating the Raman signal photons by wavelength and imaging them onto a detector. To provide sufficient separation between molecular vibrational frequencies and allow the detection of Raman photons that carry this information, the spectrograph shall combine high spatial and spectral resolution; high optical throughput; and stability over time, temperature, and environmental changes. The spectrograph shall also provide sufficient free spectral range to capture all the vibration frequencies of interest. Spectrographs using holographic transmission gratings and refractive imaging optics are ideally suited to this task. The spectrograph also shall include a notch or edge filter to block excess un-shifted laser light without significantly affecting signal photons. The following typical performance values meet these criteria:

(1) Spectral range—Range— $\leq 150$  to  $\geq 3500 \text{ cm}^{-1}$

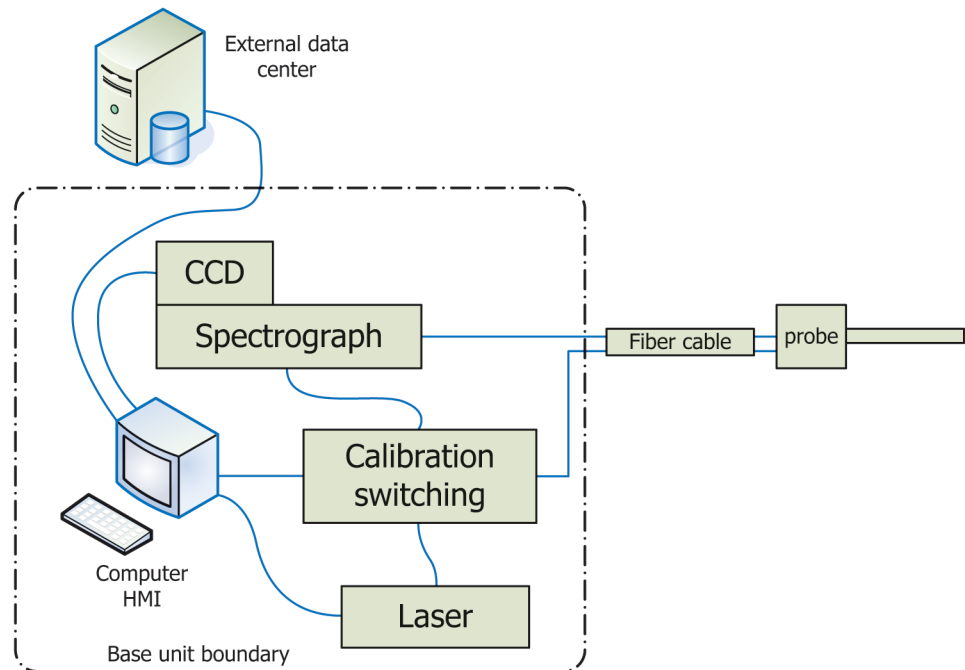

FIG. 2 Analyzer Base Unit

- (2) *Spectral resolution—Resolution*— $\leq 7 \text{ cm}^{-1}$
- (3) *Spectral thermal stability—Thermal Stability*— $\leq 0.1 \text{ cm}^{-1}/^{\circ}\text{C}$  band shift,
- (4) *Optical throughput—Throughput*—Numerical aperture (NA) of spectrograph matched to fiber NA (typically f/1.8), and
- (5) *Notch or edge filter—Edge Filter*— $\geq 8$  optical density at laser wavelength and  $\geq 80 \%$  transmission beyond  $200 \text{ cm}^{-1}$ .

7.1.2.2 *CCD*—The CCD detector is a silicon-chip-based two-dimensional array of light-sensitive pixels having the characteristics of high-quantum efficiency, high linearity, adequate dynamic range, with very low background noise, coupled with a sufficient number of pixels to support system resolution requirements. The low-noise characteristic is due to a combination of the design of the chip, cooling of the chip to reduce thermally generated signals, and low-read noise electronics. The chip shall be contained in a hermetic vacuum Dewar to prevent ambient contamination from interfering with spectral accuracy. Typical performance values:

- (1) *Quantum efficiency—Efficiency*— $\geq 40 \%$  at spectral range center;
- (2) *Spectral range—Range*—At least 4 % quantum efficiency from 400 to 1050 nm;
- (3) *Dynamic range—Range*—16-bit digital, with  $\geq 50\,000$  electron quantum well capacity;
- (4) *Read noise—Noise*— $\leq 10$  electrons; and
- (5) *Dark count—Count*— $\leq 0.5$  electrons/pixel/second, typically requires cooling to at least  $-30 \text{ }^{\circ}\text{C}$ .

7.1.2.3 *Spectrum Standard*—Light source of known spectrum used to standardize/calibrate the detection module and provide the correct mapping of scattered wavelength to a physical CCD pixel coordinates/location. Typically, an atomic emission source such as a neon light is used for this purpose.

7.1.2.4 *Raman Shift Standard*—A physical sample having known Raman shift characteristics used to determine the operating wavelength of laser module and correct for any short-term or accumulated error. The position of the spectral band(s) of this material can be used to calculate the operational wavelength of the laser:

$$\lambda_i = \frac{1}{\left(\bar{\nu} + \frac{1}{\lambda_s}\right)} \quad (1)$$

where  $\lambda_i$  is the incident wavelength (the operational wavelength of the laser) in cm,  $\lambda_s$  is the measured wavelength of the Raman band in cm, and  $\bar{\nu}$  is the accepted standard position of the Raman band of the reference material in wavenumbers.

7.1.3 *Fiber-Optic Cable*—Typically contains two individual optical fibers, one of which carries laser light to the sample, with the other returning the Raman signal back to the detection module. For Raman systems using lasers with the theoretical ability to exceed the limits set forth in EN 60079-28, there shall be some form of breakage detection or armoring associated with the cable. A typical approach is to incorporate into the cable a pair of electrical conductors that carry an intrinsically safe level of current that is integral to the laser power interlock. Interruption of this current by cable damage shuts down the laser.

7.1.3.1 *Excitation Fiber*—Carries incident light from the analyzer to the probe. Should be low OH all-glass fiber.

7.1.3.2 *Collection Fiber*—Carries scattered light from the probe to the analyzer. Should be low OH all-glass fiber.

7.1.3.3 *Interlock Conductors*—28-gauge or greater copper with capacitance and inductance sufficiently low to meet industry standard (IS) barrier requirements.

7.1.4 *Sample Probe*—The sample probe interfaces the fiber cable to the sample stream. It shall be constructed of materials compatible with the sample stream and be able to maintain stable optical performance from cryogenic temperatures in the case of LNG measurement to ambient. The probe contains a hermetically sealed window separating the optics from the sample stream. The primary functions of the probe are: removal of the Raman signal generated by laser light traveling through the excitation fiber (which would contaminate the sample spectra), imaging the laser light into the sample, superimposing an image of the collection fiber onto the illuminated sample volume, removing the majority of the unshifted laser light before leaving the probe (again to eliminate background signals), and finally, providing efficient delivery of the excitation light into, and efficient collection of the Raman signal out of, the stream to be measured.

7.1.4.1 *Optical Assembly*—Collection of lenses and filters constructed to operate from ambient to cryogenic temperatures ( $-190 \text{ }^{\circ}\text{C}$ ) or ambient to above  $150 \text{ }^{\circ}\text{C}$ . Shall be vibration- and shock-resistant (100-G shock, 10-G full spectral vibration up to 500 Hz).

7.1.4.2 *Housing*—Shall be made from a material that is chemically and physically compatible with the stream being measured. It is typically 316 stainless steel. The probe shall be rigid enough to withstand the hydrodynamic forces it will experience when

installed in the sample stream. It shall incorporate features to hermetically seal the window and fiber feed-throughs to isolate the optics from the sample and ambient environment. The housing shall have process-compatible mounting features; typically a flange or compression fitting.

7.1.4.3 *Window*—The window sealing mechanism shall be chemically compatible with the materials being analyzed and shall have a low-fluorescent background so as not to obscure spectral features. The window material and construction shall be able to withstand the sample pressure. Windows are typically constructed of ultra-pure sapphire for strength, chemical resistance, and to reduce spectral contamination. It shall be constructed such that it can maintain a hermetic seal when subjected to a standard 7 J 2.5-cm diameter steel ball impact test (per pressure vessel and hazardous atmosphere requirements).

7.1.5 *Computer Control System and User Interface*—Typically, a computer subsystem is used to interface with the CCD, collect spectra, perform calculations, as well as monitor diagnostic sensors and provide a user interface.

7.1.6 *Software*—Software is used for the following functions:

7.1.6.1 Perform Raman wavelength shift calculations,

7.1.6.2 Produce spectrum of intensity versus Raman wavelength shift,

7.1.6.3 Determine species present,

7.1.6.4 Calculate relative abundance of species present and perform calculations of quantities based on these abundances,

7.1.6.5 Track key diagnostic factors such as temperatures, spectral intensity, and laser power, and

7.1.6.6 Maintain and check instrument calibration and drift.

## **8. Hazards**

8.1 Probes can be installed in sample streams that operate at high pressure and temperature. Extra care should be taken to assure the probe cannot be accidentally ejected from the stream interface.

8.2 The probe shall be installed in such a manner that explosion hazards are eliminated in the event of an explosive sample mixture being present, either by limitation of laser power to below that which can cause ignition, or by interlock, in which a physical switch senses when liquid level is about to fall below the probe and shuts the laser off.

8.3 This test method involves the use of a Class IIb laser, which, if handled improperly, can cause eye damage. Always check the emission status of the laser when performing service work and ensure that the laser is either off or personnel are wearing appropriate laser protection eyewear.

## **9. Sampling, Test Specimens, and Test Units**

9.1 The probe tip shall be mounted in the pipe or vessel containing the liquid to be measured and positioned into the flow at least 2 in., 5 cm, or 10 % of the pipe diameter, in from the wall of the pipe or container, to ensure representative sampling.

9.2 The probe should be mounted within 45° of horizontal such that liquid immersion of the tip is assured.

9.3 The temperature and pressure shall be such as to ensure that the sample is in the liquid phase.

9.4 The probe should be engineered such that it is within the fatigue limits of expected vortex shedding induced vibrations.

9.5 The probe window and housing structure shall be designed to withstand the expected pressure and temperature of the sample being measured with a reasonable safety factor.

## **10. Preparation of Apparatus**

10.1 The laser module shall be operated within its specified ambient temperatures range to ensure the stability of the incident light.