



Standard Test Method for Treestand Fall Arrest System¹

This standard is issued under the fixed designation F2337; the number immediately following the designation indicates the year of original adoption or, in the case of revision, the year of last revision. A number in parentheses indicates the year of last reapproval. A superscript epsilon (ϵ) indicates an editorial change since the last revision or reapproval.

1. Scope

1.1 This test method covers the determination of the load capacities for treestand fall arrest systems (FAS) and components or subsystems.

1.2 This test method addresses equipment used in hunting situations requiring personal protection against falls from heights and applies to the manufacturers, distributors, purchasers, and users of such equipment.

1.3 The values stated in inch-pound units are to be regarded as standard. The values given in parentheses are mathematical conversions to SI units that are provided for information only and are not considered standard.

1.4 *This standard does not purport to address all of the safety concerns, if any, associated with its use. It is the responsibility of the user of this standard to establish appropriate safety, health, and environmental practices and determine the applicability of regulatory limitations prior to use.*

1.5 *This international standard was developed in accordance with internationally recognized principles on standardization established in the Decision on Principles for the Development of International Standards, Guides and Recommendations issued by the World Trade Organization Technical Barriers to Trade (TBT) Committee.*

2. Terminology

2.1 The terminology and definitions in the referenced documents are applicable to this practice.

2.2 Definitions:

2.2.1 *anchorage, n*—a component or structure, or both, to which a full body harness (FBH) is attached to the tree trunk.

2.2.2 *climbing belt, n*—a strap/belt (or system of straps) which is fastened about the person in a manner so as to contain the torso and stabilize the users horizontal load while either working from a vertical position to attach treestands, climbing devices, and so forth, or during ascent/descent of tree or ladder.

2.2.2.1 *Discussion*—A FBH may be constructed to additionally serve this function.

2.2.3 *connecting hardware, n*—any locking hardware that connects the FAS components in series, thus creating a linear linkage along which the maximum arrest force (MAF) acts.

2.2.3.1 *Discussion*—Includes snap hooks, carabiners, links, anchorage hardware, and buckles.

2.2.4 *connector, n*—a device that is used to connect components of a full body harness, fall restraint.

2.2.4.1 *Discussion*—Connectors include but are not limited to tethers, locking snap hooks, carabiners, deceleration devices, and specialty systems such as self-retracting treestand safety ropes, ladder climbing systems, vertical treestand safety ropes and rope grab.

2.2.5 *deceleration device, n*—any mechanism, such as a rope grab, rip stitch tether, specially woven tether, tearing or deforming tether, automatic self-retracting treestand safety ropes, etc. which serves to dissipate energy during fall arrest or otherwise limit the maximum arrest force (MAF) on a user during a fall arrest.

2.2.6 *deceleration distance, n*—the additional vertical distance a falling user travels, excluding treestand safety rope elongation and free-fall distance before stopping, from the point at which the deceleration device begins to operate.

2.2.7 *engineered products, n*—strategically designed products by a professional to meet a specific need.

2.2.8 *equivalent, a, n*—alternative designs, methods or materials used to protect against a hazard which the manufacturer can demonstrate will provide an equal or greater degree of safety for the user than the methods, materials or designs specified in the standard.

2.2.9 *fall arrest system (FAS), n*—the complete collection of equipment and components that is designed to stop a fall in progress.

2.2.10 *free fall, v*—the act of falling before a fall arrest system (FAS) begins to apply force to arrest the fall.

2.2.11 *flexible stretch tether, n*—a full body harness tether that expands and contracts following the user's movement.

2.2.12 *full body harness (FBH), n*—a component with a design of straps which is fastened about the person in a manner so as to contain the torso and distribute the fall arrest forces

¹ This test method is under the jurisdiction of ASTM Committee F08 on Sports Equipment, Playing Surfaces, and Facilities and is the direct responsibility of Subcommittee F08.18 on Treestands.

Current edition approved Dec. 1, 2021. Published December 2021. Originally approved in 2003. Last previous edition approved in 2020 as F2337 – 20. DOI: 10.1520/F2337-21.

over at least the upper thighs, pelvis, chest, and shoulders with means for attaching it to other components or subsystems.

2.2.13 *maximum arrest force (MAF), n*—the peak dynamic force exerted on the body during fall arrest.

2.2.14 *product safety sign or label, n*—sign, label, hang tag or decal affixed to a product that provides safety information about that product.

2.2.15 *rope grab, n*—a device which travels on a connecting treestand safety rope and automatically, by friction, engages the treestand safety rope and locks so as to arrest the fall of a user.

2.2.15.1 *Discussion*—A rope grab usually employs the principal of inertial locking, cam/level locking, or both (that is, Prusik, Klemheist, or Autoblock knots).

2.2.16 *safety symbols, n*—a graphic representation intended to convey a safety message without the use of words.

2.2.17 *self-recovery point, n*—the maximum distance a user can fall to minimize the risk of the user not having the ability to recover so that they are no longer suspended in a harness after a fall has been arrested.

2.2.18 *suspension relief device, n*—a device to allow relief of a person's weight on the lower extremities if suspended in a harness, or allow the user to descend to the ground.

2.2.18.1 *Discussion*—The device is to help maintain circulation in the legs and help prevent suspension trauma (blood pooling).

2.2.19 *tether, n*—a component of a treestand full body harness consisting of a flexible strap which is attached to the dorsal area of the harness for the purpose of securing the FBH directly or indirectly to an anchorage to the tree trunk.

2.2.20 *thigh/leg straps, n*—the straps, which are integrated with the buttock strap (optional) and are routed from back to front across the groin area or loop around the upper part of the thigh.

2.2.21 *total fall distance, n*—the maximum vertical distance between a full body harness anchorage and the lowest extremity of the body before and after the fall is arrested including tether extension or drop distance, or both (refer to Fig. 1 for clarification of total fall distance calculation).

2.2.22 *treestand, n*—a device designed to be affixed to a tree so as to permit an individual to sit or stand thereon for the purpose of attaining an elevated position from which to observe, photograph, or hunt.

2.2.23 *treestand safety rope, n*—component consisting of a flexible line for connection to a tree trunk at one end to hang vertically and which serves as a means for connecting other components of a fall arrest system.

3. Summary of Test Method

3.1 One system test shall consist of the testing of one individual fall arrest system unit for maximum arrest force (MAF) in accordance with the procedures in 6.1.

3.2 One system test shall consist of the testing of one individual fall arrest system unit for performance in accordance with the procedures in 6.2.

3.3 One system test shall consist of testing one individual fall arrest system unit for dynamic strength in accordance with the procedures in Section 7.

3.4 One climbing belt test shall consist of testing one individual climbing belt (for use only if FAS includes integral climbing belt) in accordance with the procedures in Section 8.

3.5 For each test a test weight torso having the physical properties described in 5.4 or 5.5 shall be dropped from an adequate elevation to simulate a free-fall motion from a treestand platform.

3.6 One static load test shall consist of testing one (1) individual Suspension Relief Device in accordance with the procedures in Section 9 of this standard.

3.6.1 A Suspension Relief Device shall be provided with each FAS/FBH complete with instructions. This device shall be capable of allowing the user to relieve the load on the user's lower extremities if suspended in a harness to help maintain circulation in the legs and help prevent suspension trauma (blood pooling). The capacity rating of the Suspension Relief Device shall be equal to the FAS rated capacity.

4. Significance and Use

4.1 This test method is intended to measure the maximum arrest force and dynamic strength on treestand FAS and components or subsystems. This test is intended for program quality assurance and production quality control purposes. It is not intended to be an independent material or product acceptance test.

5. Apparatus

5.1 A vertical, rigid, round wood pole shall be used to mount the test weight torso and fall arrest system (FAS) such that pole deflection is minimized during testing.

5.2 The mounting pole diameter shall be 10 ± 1 in. and shall have a minimum height necessary for free fall to meet the provisions of 6.1.4, 6.2.4, 7.1.3 – 7.1.6, and 8.1.3.

5.3 The mounting pole shall have a wood dowel/stop affixed horizontally on the backside of the pole at the point just below where the anchorage is attached. The purpose of this stop is to prevent any vertical slippage of the anchorage during testing. This wood dowel/stop shall be 3 ± 0.25 in. in diameter, smooth, cylindrical in shape and at least 1.5 in. in length.

5.4 The test weight torso used during the performance test shall weigh 220 ± 2 lb. The test weight torso shall be as shown in Fig. 2.

5.5 The test weight torso used during the dynamic strength test shall weigh 300 ± 3 lb or the rated capacity of the harness ± 3 lb as specified on the label attached to unit to be tested.

5.6 The test weight torso and test operator shall be raised to the required elevation by means of a man lift, forklift/basket, or other device capable of providing means to ascend to the proper elevation and provide a stable and safe working environment.

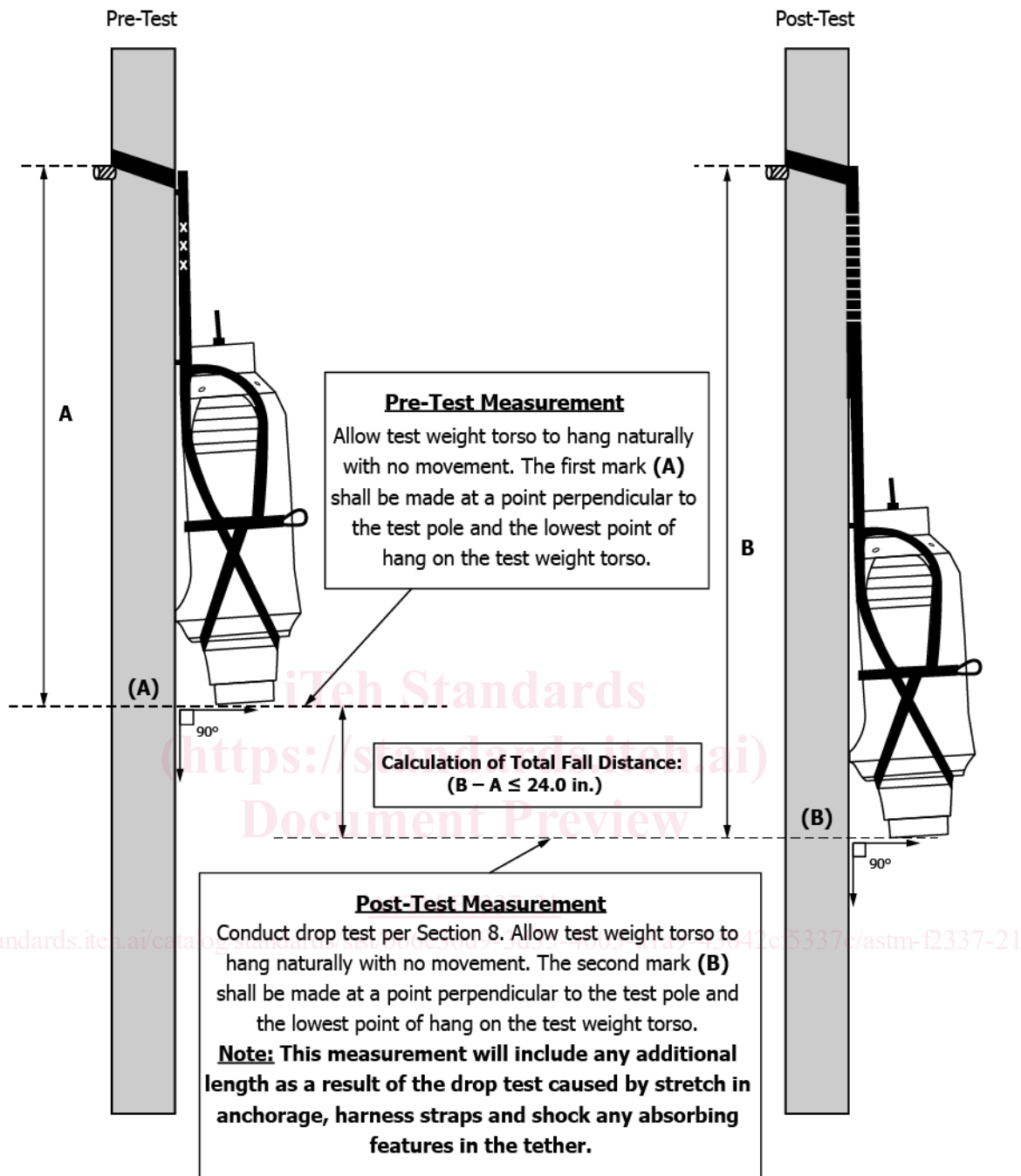

NOTE 1—See Fig. 2 for specification of typical test weight torso that includes various weight configurations.

FIG. 1 Clarification of Total Fall Distance Calculation (See Section 7)

5.7 The free fall may be induced by manual or automatic means which do not obstruct continuous free fall of the test weight torso and not hinder or alter the angle of the test weight torso during free fall.

5.8 The instrumentation used to measure the MAF of the FAS should consist of a force sensor or load cell capable of measuring peak loads up to 3375 lb (15 kN). The recording data channel shall have a minimum sampling rate of 1000 samples per second and an active frequency response band up to a corner frequency of 100 Hz + 1.2 dB, -3 dB.

6. Performance Test Procedure

6.1 The following procedures shall apply to one individual unit of a given FAS with the test torso as given in 5.4 dropped “feet first.”

6.1.1 Read instructions accompanying the test subject to ascertain the proper procedure for use and donning. Secure the FAS anchorage to the mounting pole and the test torso in accordance with the device manufacturer’s instructions.

6.1.2 The force sensor or load cell shall be placed in series with the full body harness and tether or anchorage. The drop

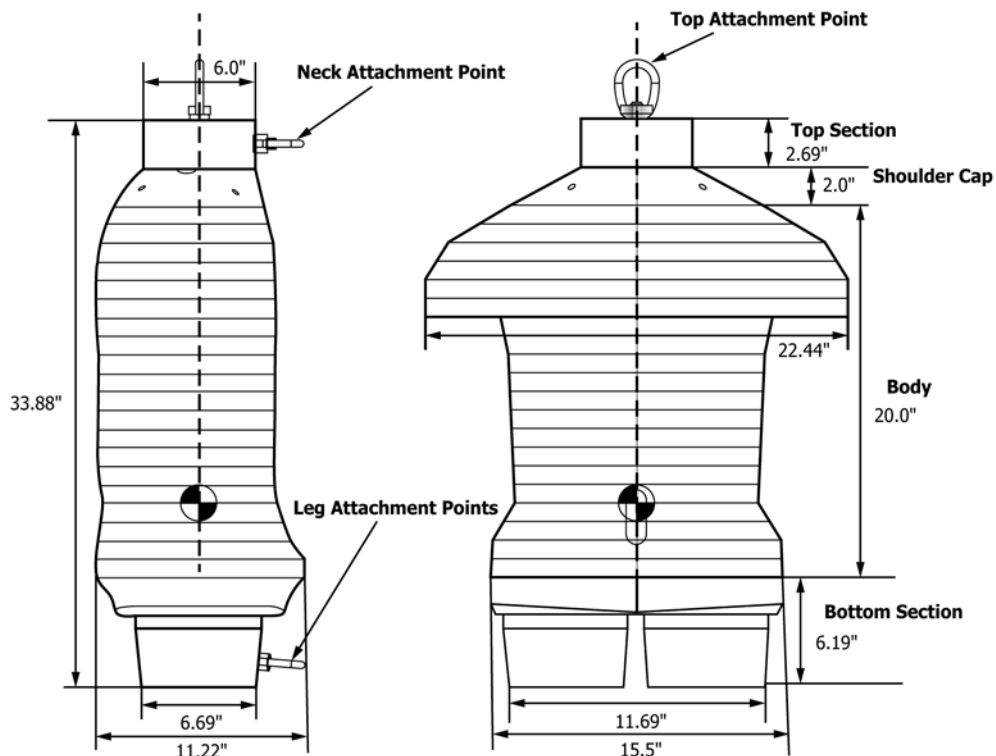

Materials: Top Section-Aluminum
Shoulder Cap-Steel, Body-Wood
Bottom Section-Steel

Note: All dimensions are in inches. Various weight configurations include: 220, 300 and 350

NOTE: Information on the source of supply of the torso may be obtained from ASTM F08.18 Subcommittee chair.

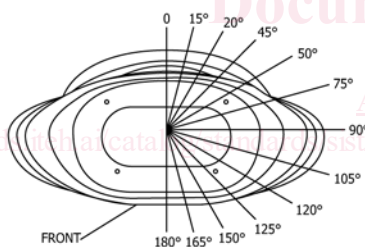
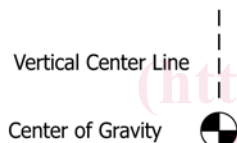

Polar Coordinates of Horizontal Half Sections H01-H20 of Torso
(All dimensions are in inches with tolerance of +/- 1/8 inch).

	Back 0°	15°	30°	45°	60°	75°	90°	105°	120°	135°	150°	165°	Front 180°
A	3.43	3.50	3.78	4.33	5.20	6.14	6.09	6.09	6.65	6.02	5.28	4.76	4.61
B	3.68	3.74	4.09	4.72	5.83	7.07	8.37	8.13	7.46	6.59	5.73	5.18	5.02
C	3.94	3.98	4.41	5.12	6.46	7.99	10.04	9.57	8.27	7.17	6.18	5.59	5.43
D	4.02	4.09	4.51	5.12	6.34	8.09	10.63	10.16	8.43	7.15	6.28	5.69	5.49
E	4.09	4.21	4.61	5.12	6.22	8.19	11.22	10.75	8.58	7.13	6.38	5.79	5.55
F	4.09	4.21	4.61	5.12	6.22	8.19	11.22	10.75	8.58	7.13	6.38	5.79	5.55
G	4.09	4.13	4.25	4.61	5.16	6.02	7.28	6.85	6.26	5.83	5.51	5.55	5.55
H	4.09	4.13	4.25	4.59	5.14	6.00	7.05	6.85	6.34	5.79	5.55	5.51	5.49
I	4.09	4.13	4.25	4.57	5.12	5.98	6.81	6.85	6.42	5.75	5.59	5.47	5.43
J	4.06	4.09	4.21	4.53	5.08	5.93	6.75	6.85	6.40	5.81	5.59	5.47	5.43
K	4.02	4.06	4.17	4.49	5.04	5.87	6.00	6.85	6.38	5.87	5.59	5.47	5.43
L	4.02	4.04	4.17	4.49	5.02	5.81	6.61	6.79	6.36	5.87	5.59	5.47	5.43
M	4.02	4.02	4.17	4.49	5.00	5.75	6.54	6.73	6.34	5.87	5.59	5.47	5.43
N	3.98	3.98	4.13	4.49	5.00	5.75	6.52	6.69	6.30	5.89	5.65	5.47	5.47
O	3.94	3.94	4.09	4.49	5.00	5.75	6.50	6.65	6.26	5.91	5.71	5.47	5.51
P	4.04	4.04	4.19	4.53	5.02	5.75	6.45	6.61	6.24	5.93	5.57	5.37	5.35
Q	4.13	4.13	4.29	4.57	5.04	5.75	6.42	6.57	6.22	5.94	5.43	5.28	5.20
R	4.49	4.55	4.76	5.16	5.87	6.65	7.05	7.09	6.75	6.24	5.71	5.45	5.35
S	4.84	4.96	5.24	5.75	6.09	7.56	7.68	7.60	7.28	6.54	5.98	5.63	5.51
T	5.67	5.75	6.18	6.69	7.40	7.80	7.80	7.72	7.32	6.69	5.98	5.67	5.55
U	5.67	5.75	6.18	6.69	7.40	7.80	7.80	7.72	7.32	6.69	5.98	5.67	5.55

FIG. 2 Example of Typical Test Weight Torso for Treestand FAS/FBH

distance required is a distance of 6 ft or twice the maximum tether length or whichever is less. Any length added from the force sensor or load cell and any connecting hardware must be subtracted from the drop distance.

6.1.3 Prior to performing the drop test, the anchorage shall be properly secured with a permanent wood dowel/stop specified in 5.3 and placed directly under the anchorage to the backside of the pole to eliminate movement during test. All

surfaces shall be free of burs or sharp edges to reduce the possibility of damage to the anchorage which would invalidate the test.

6.1.4 Attach the release mechanism to the test weight torso at a point located at the top (see Fig. 2 for clarification). The test weight torso specified in 5.4 shall be suspended from a single attachment point at the top facing away from the test pole with the center of gravity on the test pole (see Fig. 1 for clarification). The test weight torso shall be raised to an elevation such that its free fall begins at the point above the anchorage equal to the maximum length of the tether (if adjustable) or a distance which allows 6 ft of free fall, whichever is less. The test weight torso shall be located as close to the pole as practical or not greater than 1 ft with no tension in the tether prior to release. In such a manner, the free-fall distance will equal twice the maximum available length or 6 ft, whichever is less.

6.1.5 The test weight torso shall be dropped “feet first” or otherwise released as if to simulate a free-fall from a treestand platform. The fall should be essentially vertical with minimal “swinging” of the test subject. The fall shall be closely observed for any unusual or unsafe action. Measure and record the maximum arrest force (MAF), and whether or not any test weight torso detaches from the harness. After the drop, the test weight torso is to remain suspended by the FAS for a period of 2 min.

6.1.6 After the FAS has been engaged, the test weight torso shall be lowered to the ground and the FAS inspected for damage. Compare test results to the requirements set forth in 11.1 – 11.4.

6.2 The following procedures shall apply to one individual unit of a given FAS with the test weight torso as given in 5.4 dropped “face first” (see Fig. 3 for clarification).

6.2.1 Read instructions accompanying the test subject to ascertain the proper procedure for use and donning. Secure the FAS anchorage to the mounting pole and the test weight torso in accordance with the device manufacturer’s instructions.

6.2.2 The drop distance required is a distance of 6 ft or twice the maximum tether length, or whichever is less. Any added length from any connecting hardware must be subtracted from the drop distance.

6.2.3 Prior to performing the drop test, the anchorage shall be properly secured with a permanent wood dowel/stop as specified in 5.3 and placed directly under the anchorage to the backside of the pole to eliminate movement during test.

6.2.4 Attach the quick release mechanism to the test weight torso at three (3) points, one on each leg and one located at the neck (see Fig. 3 for clarification) or other means of attachment that will allow the test torso to be released appropriately. Bridle configuration shall be constructed of a material that is nonabrasive and also configured so that it allows for an unobstructed drop during test procedure. The test weight torso shall be positioned so that the vertical axis will be horizontal or perpendicular to the test pole, or both, with the front/chest of the torso facing downward. The test weight torso orientation shall be positioned so that the neck end is directly to the left of the mounting pole with the legs directed to the right. The release point for the torso will be vertically above the center of gravity of the torso when oriented “face first.” The test weight torso shall be raised to an elevation such that its free-fall begins

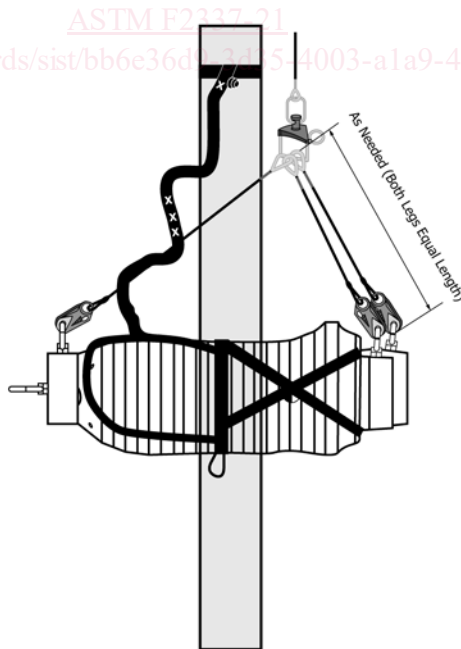

Note: Bridle Configuration shall be constructed of a material that is nonabrasive and also configured so that it allows for an unobstructed drop during test procedure.

FIG. 3 Clarification of Bridle Configuration for “Face First” Drop