



Designation: C359 – 21

## Standard Test Method for Early Stiffening of Hydraulic-Cement (Mortar Method)<sup>1</sup>

This standard is issued under the fixed designation C359; the number immediately following the designation indicates the year of original adoption or, in the case of revision, the year of last revision. A number in parentheses indicates the year of last reapproval. A superscript epsilon ( $\epsilon$ ) indicates an editorial change since the last revision or reapproval.

### 1. Scope\*

1.1 This test method covers the determination of early stiffening in hydraulic-cement mortar.

1.2 The values stated in SI units are to be regarded as standard. The values given in parentheses after SI units are provided for information only and are not considered standard.

1.3 The text of this standard references notes and footnotes which provide explanatory material. These notes and footnotes (excluding those in tables and figures) shall not be considered as requirements of the standard.

1.4 *This standard does not purport to address all of the safety concerns, if any, associated with its use. It is the responsibility of the user of this standard to establish appropriate safety, health, and environmental practices and determine the applicability of regulatory limitations prior to use. (Warning—Fresh hydraulic-cementitious mixtures are caustic and may cause chemical burns to skin and tissue upon prolonged exposure.<sup>2</sup>)*

1.5 *This international standard was developed in accordance with internationally recognized principles on standardization established in the Decision on Principles for the Development of International Standards, Guides and Recommendations issued by the World Trade Organization Technical Barriers to Trade (TBT) Committee.*

### 2. Referenced Documents

2.1 *ASTM Standards:*<sup>3</sup>

[C183/C183M Practice for Sampling and the Amount of Testing of Hydraulic Cement](#)

[C185 Test Method for Air Content of Hydraulic Cement Mortar](#)

[C187 Test Method for Amount of Water Required for Nor-](#)

[mal Consistency of Hydraulic Cement Paste](#)

[C219 Terminology Relating to Hydraulic and Other Inorganic Cements](#)

[C305 Practice for Mechanical Mixing of Hydraulic Cement Pastes and Mortars of Plastic Consistency](#)

[C511 Specification for Mixing Rooms, Moist Cabinets, Moist Rooms, and Water Storage Tanks Used in the Testing of Hydraulic Cements and Concretes](#)

[C670 Practice for Preparing Precision and Bias Statements for Test Methods for Construction Materials](#)

[C778 Specification for Standard Sand](#)

[C1005 Specification for Reference Masses and Devices for Determining Mass and Volume for Use in Physical Testing of Hydraulic Cements](#)

[E2251 Specification for Liquid-in-Glass ASTM Thermometers with Low-Hazard Precision Liquids](#)

### 3. Terminology

3.1 For definitions of terms used in this test method, refer to Terminology [C219](#).

### 4. Summary of Test Method

4.1 A mortar is prepared with the cement to be tested, using specified quantities of cement, standard sand, and an amount of water that will produce a mortar with an initial penetration of  $46 \pm 3$  mm, using the modified Vicat apparatus. Measurements of penetration are made at stipulated intervals after the beginning of the mixing procedure. Upon completion of the first series of penetration measurements, the mortar is returned to the mixer to be remixed. Following the remix procedure, an additional penetration, termed the remix penetration, is determined. The report is a tabulation of the penetration measurements and the amount of mixing water used.

### 5. Significance and Use

5.1 The purpose of this test method is to determine the degree to which a cement mortar develops early stiffening. It is intended for use by those interested in methods for determining the potential early stiffening of hydraulic-cement.

5.2 When used for estimating the relative tendency of a cement to manifest early stiffening, a judgment may be made by comparing the behavior in the penetration series (see [10.4.1](#) and [10.4.2](#)) and the remix procedure (see [10.4.3](#)) to differentiate a relatively less serious and less persistent tendency to

<sup>1</sup> This test method is under the jurisdiction of ASTM Committee C01 on Cement and is the direct responsibility of Subcommittee C01.30 on Time of Set.

Current edition approved Dec. 15, 2021. Published December 2021. Originally approved in 1955. Last previous edition approved in 2020 as C359 – 20. DOI: 10.1520/C0359-21.

<sup>2</sup> Section on Safety, Manual of Cement Testing, *Annual Book of ASTM Standards*, Vol 04.01.

<sup>3</sup> For referenced ASTM standards, visit the ASTM website, [www.astm.org](http://www.astm.org), or contact ASTM Customer Service at [service@astm.org](mailto:service@astm.org). For *Annual Book of ASTM Standards* volume information, refer to the standard's Document Summary page on the ASTM website.

\*A Summary of Changes section appears at the end of this standard

early stiffening (false set) from one that is more persistent and, consequently, more serious (flash set).

5.3 Severe false setting in a cement may cause difficulty from a placing and handling standpoint, but it is not likely to cause difficulties where concrete is mixed for a longer time than usual, as usually occurs in transit mixing, or where it is remixed prior to placing or transporting, in concrete pumping operations. It is most likely noticed where concrete is mixed for a short period of time in stationary mixers and transported to the forms in non-agitating equipment, as on some paving jobs, and when concrete is made in an on-site batch plant.

5.4 Cements with severe false setting usually require slightly more mixing water to produce the same consistency, which may result in slightly lower strengths and increased drying shrinkage.

5.5 Early stiffening resulting from false set is not likely to cause a cement to fail the applicable time of setting requirement.

5.6 Early stiffening resulting from flash set, depending on severity, can cause a cement to fail the applicable time of setting requirement.

## 6. Apparatus

6.1 *Vicat Apparatus*, conforming to the requirements of Fig. 1 in Test Method C187, with the following modifications:

6.1.1 The 1 mm needle shall be replaced by a mass, such that the total mass of the 10 mm plunger, indicator, and added mass shall be  $400 \pm 0.5$  g.

6.2 *Spoon*, conforming to the requirements of Test Method C185.

6.3 *Mixer, Bowl, Paddle, and Scraper*, conforming to the requirements of Practice C305.

6.4 *Glass Graduates*, 200 or 250 mL capacity, conforming to the requirements of Specification C1005.

6.5 *Masses and Mass Determining Devices*, conforming to the requirements of Specification C1005. The devices for determining mass shall be evaluated for continuing precise performance utilizing the procedure in Specification C1005, Appendix X1, using a verification check mass of approximately 1000 g.

6.6 *Thermometer*, ASTM No. S12C or S12F, conforming to the requirements of Specification E2251.

6.7 *Flat Trowel*, having a sharpened straight-edged steel blade 100 to 150 mm in length. The edges when placed on a plane surface shall not depart from straightness by more than 1 mm.

6.8 *Clock Timer*, having a readability to the nearest second.

6.9 *Containers*, approximately 50 by 50 by 150 mm (2 by 2 by 6 in.) inside dimensions (Fig. 1). These containers, which may be made of any suitable materials such as sheet metal or plastic, shall be rigid, watertight, and at least 50 mm (2 in.) deep.

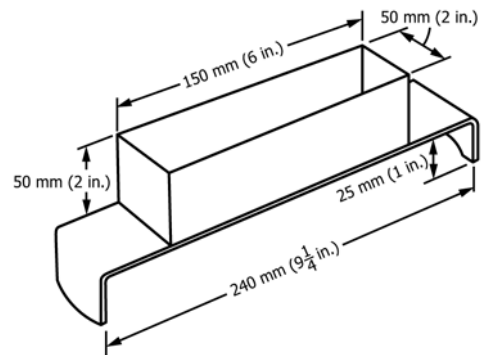

FIG. 1 Container for Early Stiffening Tests

## 7. Reagents and Materials

7.1 *Standard Sand, 20-30 and Graded*, conforming to the requirements of Specification C778.

7.2 *Mixing Water*—Potable water is satisfactory for routine tests. Use reagent water for all referee and cooperative tests.

## 8. Sampling

8.1 When the test is part of acceptance testing, sample the cement in accordance with Practice C183/C183M.

## 9. Conditioning

9.1 Maintain the temperature and humidity of the mixing room in accordance with Specification C511.

9.2 The mixing apparatus shall be within the temperature range of the mixing room prior to testing.

NOTE 1—This test method may adjust the temperature of either the mix water, cement, sand or a combination in order to obtain a specified mortar temperature range. Starting the test with the initial dry material and water temperatures within the mixing room temperature range is recommended.

## 10. Procedure

10.1 *Batch*—Mix at one time 600 g of cement, 300 g of graded standard sand, 300 g of 20-30 standard sand, and an amount of water that produces a mortar with an initial penetration of  $46 \pm 3$  mm.

10.2 *Mixing of Mortar*—Mix in the mechanical mixer as follows:

10.2.1 Place the sand and cement in the dry bowl, and mix the dry materials for a few seconds with the spoon.

10.2.2 Place the bowl in the mixer, set the paddle in place, and mix the dry materials for 10 s at a slow speed ( $140 \pm 5$  r/min).

10.2.3 With the mixer operating at a slow speed ( $140 \pm 5$  r/min), add the entire quantity of mixing water within 5 s. Stop the mixer, quickly change to a medium speed ( $285 \pm 10$  r/min), and continue the mixing for 1 min, timing from the first addition of water.

10.2.4 Stop the mixer, scrape the sides of the mixing bowl with the rubber scraper, and quickly place the thermometer in the mortar. Allow it to stand undisturbed for the remainder of a 45-s interval from the time of stopping the mixer.

10.2.5 Read the temperature, remove the thermometer, start the mixer, and mix for 15 s at a medium speed (285 ± 10 r/min). If the mortar temperature is not in the range from 23 ± 2.0 °C, discard the batch and adjust the temperature of the water or sand, or both, to give the required temperature.

### 10.3 Filling Container:

10.3.1 Immediately after completion of the mixing, remove the bowl from the mixer and with a spoon, uniformly distribute a portion of the mortar into the container until the container is heaping full. Quickly and gently place each spoonful of mortar in the container. When removing the mortar from the bowl, do not remove the material pushed up on the side of the bowl by the paddle. After the container has been filled, reassemble the mixer, cover the bowl with a lid, and retain the remaining mortar for a remix test to be performed later. To compact the mortar in the container, lift the container approximately 80 mm (3 in.) from the table with both hands and rap it twice against the surface of the table.

10.3.2 With the leading edge slightly raised, strike off the mortar with one stroke of the trowel along the length of the container. Then remove the excess mortar by means of a sawing motion with the straightedge of the trowel along the length of the container in a direction opposite to that used in striking off. Then, smooth the surface of the mortar with a single stroke of the trowel.

### 10.4 Penetration Tests:

10.4.1 After filling the container, immediately place the 10 mm plunger of the modified Vicat apparatus in contact with the surface of the mortar at the midpoint of the container on the longitudinal center line. Set the movable indicator at zero. Release the plunger 3 min after the beginning of the wet mixing and record, as the initial penetration, the depth in millimetres to which the plunger has settled below the surface 10 s after being released. If the plunger does not settle to a depth of 46 ± 3 mm, discard the batch and adjust the quantity of water to produce the required consistency.

10.4.2 Immediately withdraw and clean the plunger. In a similar manner, determine, after moving the Vicat apparatus to the desired location, the penetrations at intervals of 5, 8, and 11 min after the beginning of mixing. Do not move the filled container until these measurements are completed. Make all penetrations along the longitudinal center line of the container. Obtain 5 and 8-min penetrations at a distance of approximately 40 mm (1½ in.) from each end of the container, respectively, and determine the 11-min penetration at a point approximately midway between the points at which the initial and 5-min penetrations were determined.

10.4.3 At the completion of the measurement of the 11-min penetration, immediately return the mortar in the container to the bowl. Start the mixer, raise the bowl into mixing position, and remix the contents of the bowl at medium speed (285 ± 10 r/min) for 1 min. Fill a clean container as outlined in 10.3.1 and 10.3.2, and determine the penetration 45 s after completion of mixing.

## 11. Calculation

11.1 *Early Stiffening Amount*—The change in penetration from the initial penetration to the 11 min penetration.

11.1.1 Calculate as follows:

$$A - D$$

where:

- A = initial penetration,
- B = penetration at 5 min,
- C = penetration at 8 min,
- D = penetration at 11 min, and
- E = penetration after REMIX.

11.1.2 Report to the nearest mm.

11.2 *Average Early Stiffening Rate*—An average of the rate of penetration change between each set of measurements.

11.2.1 Calculate as follows:

$$\frac{\frac{A - B}{2} + \frac{B - C}{3} + \frac{C - D}{3}}{3}$$

where A, B, C, D are as defined in 11.1.1.

11.2.2 Report to the nearest 0.1 mm/min.

11.3 *Early Stiffening Recovery*—The percent penetration recovery accomplished with the REMIX procedure.

11.3.1 Calculate as follows:

$$100 \cdot \frac{E}{A}$$

where E and A are as defined in 11.1.1 (see Note 3).

11.3.2 Report to the nearest percent.

## 12. Report

12.1 Report the measured and calculated values as shown below:

Mixing Water	_____ mL
Initial Penetration	_____ mm
5-min Penetration	_____ mm
8-min Penetration	_____ mm
11-min Penetration	_____ mm
Remix Penetration	_____ mm
Early Stiffening Amount	_____ mm
Average Early Stiffening Rate	_____ mm/min
Early Stiffening Recovery	_____ %

## 13. Precision and Bias<sup>4</sup>

13.1 *Early Stiffening Amount*:

13.1.1 The single-operator standard deviation has been found to be 1.8 mm over a range from 35 to 49 mm. Therefore, results of two properly conducted tests by the same operator on the same material are not expected to differ by more than 5 mm. (see Note 4).

13.1.2 The multilaboratory standard deviation has been found to be 2.5 mm over a range from 35 to 49 mm. Therefore, results of two properly conducted tests from two different laboratories on samples of the same cement are not expected to differ by more than 7 mm. (see Note 4).

13.2 *Average Early Stiffening Rate*:

13.2.1 The single-operator standard deviation has been found to be 0.50 mm/min over a range from 4.0 to 8.0 mm/min.

<sup>4</sup> Supporting data have been filed at ASTM International Headquarters and may be obtained by requesting Research Report RR:C01-1008. Contact ASTM Customer Service at service@astm.org.