



Designation: D5346 – 17 (Reapproved 2021)

Standard Test Method for Determination of the Pour Point of Petroleum Oil Used in Fatliquors and Softening Compounds¹

This standard is issued under the fixed designation D5346; the number immediately following the designation indicates the year of original adoption or, in the case of revision, the year of last revision. A number in parentheses indicates the year of last reapproval. A superscript epsilon (ϵ) indicates an editorial change since the last revision or reapproval.

1. Scope

1.1 This test method covers the determination of the pour point of petroleum oils used in the softening and stuffing of leather, and in the manufacture of fatliquors and other softening and stuffing compounds. This test method was derived from Test Method **D97** and ALCA Method H-18.

1.2 The values stated in SI units are to be regarded as standard. No other units of measurement are included in this standard.

1.3 *This standard does not purport to address all of the safety concerns, if any, associated with its use. It is the responsibility of the user of this standard to establish appropriate safety, health, and environmental practices and determine the applicability of regulatory limitations prior to use.*

1.4 *This international standard was developed in accordance with internationally recognized principles on standardization established in the Decision on Principles for the Development of International Standards, Guides and Recommendations issued by the World Trade Organization Technical Barriers to Trade (TBT) Committee.*

2. Referenced Documents

2.1 ASTM Standards:²

D97 Test Method for Pour Point of Petroleum Products
E1 Specification for ASTM Liquid-in-Glass Thermometers
E2251 Specification for Liquid-in-Glass ASTM Thermometers with Low-Hazard Precision Liquids

2.2 Other Document:

ALCA Method H-18 Cloud and Pour Point³

¹ This test method is under the jurisdiction of ASTM Committee **D31** on Leather and is the direct responsibility of Subcommittee **D31.08** on Fats and Oils.

Current edition approved Dec. 1, 2021. Published January 2022. Originally approved in 1993. Last previous edition approved in 2017 as D5346–17. DOI: 10.1520/D5346-17R21.

² For referenced ASTM standards, visit the ASTM website, www.astm.org, or contact ASTM Customer Service at service@astm.org. For *Annual Book of ASTM Standards* volume information, refer to the standard's Document Summary page on the ASTM website.

³ Available from American Leather Chemists Assn., Texas Tech University, P.O. Box 45300, Lubbock, TX 79409.

3. Significance and Use

3.1 This test method is intended to determine the pour point of petroleum oils used in the softening and stuffing of leather, as well as those used in the manufacture of products for such purpose. The pour point of petroleum oils is measured for the purpose of quality assurance.

4. Apparatus (see Fig. 1)

4.1 *Test Jar*, clear cylindrical glass, flat bottom, 30 to 33.5-mm inside diameter, and 115 to 125-mm height. To indicate sample height the jar should be marked with a line 54 mm \pm 3 mm above the inside bottom.

4.2 *Thermometers*, having ranges shown below and conforming to the requirements prescribed in Specifications **E1** or **E2251** for thermometers:

Thermometer	Temperature	Thermometer Number	
	Range	ASTM	IP
High cloud and pour	–38 to +50 °C	5C or S5C	1C
Low cloud and pour	–80 to +2 °C	6C	2C
Melting point	+32 to +127 °C	61C	63C

4.2.1 Since separation of liquid column thermometers occasionally occurs and may escape detection, thermometers should be checked immediately prior to the test and used only if they prove accurate within ± 1 °C (for example ice point).

4.3 *Cork*, to fit the test jar, bored centrally for the test thermometer.

4.4 *Jacket*, metal or glass, watertight, cylindrical, flat bottom, 115 mm in depth, 42 mm to 50 mm inside diameter. It must be supported firmly in a vertical position in the cooling bath of 4.7 so that not more than 25 mm projects out of the cooling medium.

4.5 *Disk*, cork or felt, 6 mm thick to fit loosely inside the jacket.

4.6 *Gasket*, to fit snugly around the outside of the test jar and loosely inside the jacket. The gasket may be made of rubber, leather, or other material that is elastic enough to cling to the test jar and hard enough to hold its shape. Its purpose is to prevent the test jar from touching the jacket.

4.7 *Bath or Baths*, maintained at prescribed temperatures with a firm support to hold the jacket vertical. The required bath temperatures may be obtained by refrigeration if

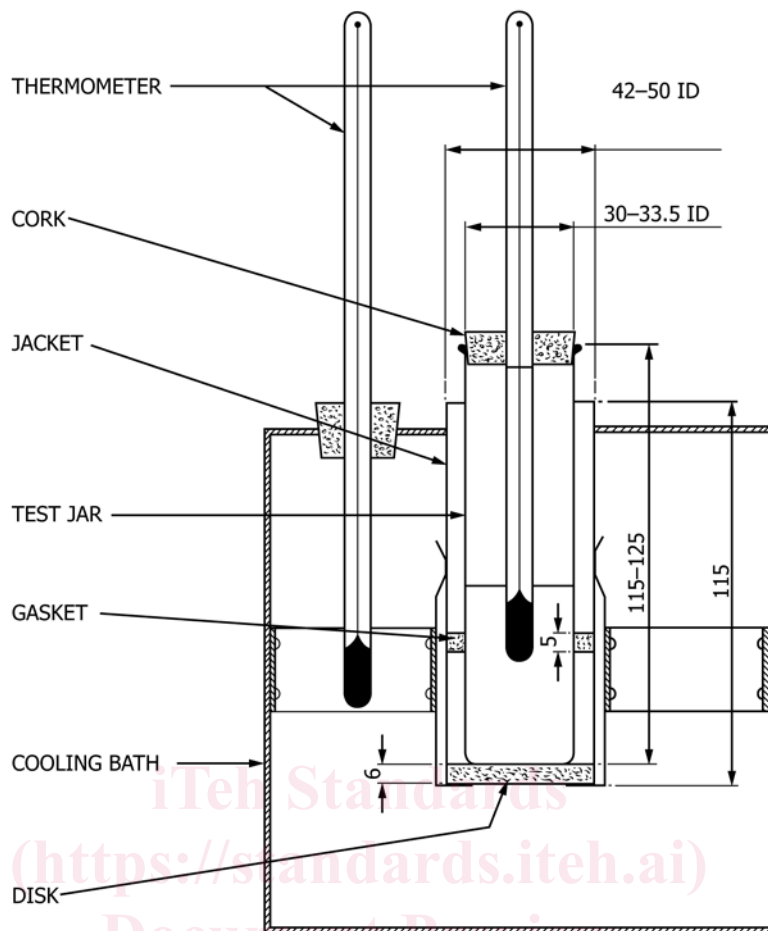

NOTE 1—Dimensions are in millimetres.

FIG. 1 Apparatus for Pour Point Test

ASTM D5346-17(2021)

available, otherwise by suitable freezing mixtures. Freezing mixtures commonly used for temperatures down to those shown are as follows:

	For Temperatures Down
Ice and water	9 °C
Crushed ice and sodium chloride crystals	-12 °C
Crushed ice and calcium chloride crystals	-27 °C
Acetone or petroleum naphtha (see Section 5) chilled in a covered metal beaker with an ice-salt mixture to -12 °C then with enough solid carbon dioxide to give the desired temperature.	-57 °C

NOTE 1—There are automatic pour point testers available and in use which may be advantageous in the saving of test time, permit the use of smaller samples, and have other factors which may merit their use. If automatic testers are used, the user must ensure that all of the manufacturer's instructions for calibration, adjustment and operation of the instrument are followed. It must be reported that the pour point was determined by an automatic instrument. Precision of automatic pour point testers has not been determined. In any case of dispute, the pour point as determined by the manual method described herein shall be considered the reference test.

5. Reagents and Materials

5.1 The following solvents of technical grade are appropriate for low-temperature bath media.

- 5.1.1 *Acetone*. (**Warning**—Extremely flammable.)
- 5.1.2 *Alcohol, Ethanol*. (**Warning**—Flammable.)

5.1.3 *Alcohol, Methanol*. (**Warning**—Flammable. Vapor harmful.)

5.1.4 *Petroleum Naphtha*. (**Warning**—Combustible. Vapor harmful.)

5.1.5 *Solid Carbon Dioxide*. (**Warning**—Extremely cold - 78.5 °C.)

6. Procedure

6.1 Pour the oil into the test jar to the level mark. When necessary, heat the oil in a water bath until it is just sufficiently fluid to pour into the test jar.

NOTE 2—When it is known that a sample has been heated to a temperature higher than 45 °C during the preceding 24 h or when the thermal history of the sample is not known, keep the sample at room temperature for 24 h before testing it.

6.2 Close the test jar with the cork carrying the high-pour thermometer (4.2). In the case of pour points above 36 °C, use a higher range thermometer such as IP 3C or ASTM 61C. Adjust the position of the cork and thermometer so the cork fits tightly, the thermometer and the jar are coaxial, and the thermometer bulb is immersed so the beginning of the capillary is 3 mm below the surface of the oil.

6.3 For the measurement of pour point, subject the oil in the test jar to the following preliminary treatment:

6.3.1 *Oils Having Pour Points Above – 33 °C*—Heat the oil without stirring to 9 °C above the expected pour point, but to at least 45 °C, in a bath maintained at 12 °C above the expected pour point, but at least 48 °C. Transfer the test jar to a water bath maintained at 24 °C and commence observations for pour point.

6.3.2 *Oils Having Pour Points of – 33 °C and Below*—Heat the oil without stirring to 45 °C in a bath maintained at 48 °C and cool to 15 °C in a water bath maintained at 6 °C. Remove the high cloud and pour thermometer and place the low cloud and pour thermometer in position.

6.4 See that the disk, gasket, and the inside of the jacket are clean and dry. Place the disk in the bottom of the jacket. Place the gasket around the test jar, 25 mm from the bottom. Insert the test jar in the jacket. Never place a jar directly into the cooling medium.

6.5 After the oil has cooled to allow the formation of paraffin wax crystals, take great care not to disturb the mass of oil nor permit the thermometer to shift in the oil; any disturbance of the spongy network of wax crystals will lead to low and erroneous results.

6.6 Pour points are expressed in integers that are positive or negative multiples of 3 °C. Begin to examine the appearance of the oil when the temperature of the oil is 9 °C above the expected pour point (estimated as a multiple of 3 °C). At each test thermometer reading that is a multiple of 3 °C below the starting temperature, remove the test jar from the jacket. To remove condensed moisture that limits visibility, wipe the surface with a clean cloth moistened in alcohol (ethanol or methanol). Tilt the jar just enough to ascertain whether there is a movement of the oil in the test jar. The complete operation of removal, wiping, and replacement shall require not more than 3 s.

6.6.1 If the oil has not ceased to flow when its temperature has reached 27 °C, transfer the test jar to the next lower temperature bath per the following schedule:

- Oil is at +27 °C, move to 0 °C bath,
- Oil is at +9 °C, move to –18 °C bath,
- Oil is at –6 °C, move to –33 °C bath,
- Oil is at –24 °C, move to –51 °C bath,
- Oil is at –42 °C, move to –69 °C bath.

6.6.2 As soon as the oil in the jar does not flow when tilted, hold the jar in a horizontal position for 5 s, as noted by an accurate timing device and observe carefully. If the oil shows any movement, replace the test jar immediately in the jacket and repeat a test for flow at the next temperature, 3 °C lower.

6.7 Continue in this manner until a point is reached at which the oil shows no movement when the test jar is held in a horizontal position for 5 s. Record the observed reading of the test thermometer.

NOTE 3—To determine compliance with existing specifications having

pour point limits at temperatures not divisible by 3 °C, it is acceptable practice to conduct the pour point measurement according to the following schedule: Begin to examine the appearance of the oil when the temperature of the oil is 9 °C above the specification pour point. Continue observations at 3 °C intervals as described in 6.6 and 6.7 until the specification temperature is reached. Report the sample as passing or failing the specification limit.

6.8 For black oil, cylinder stock and nondistillate fuel oil, the result obtained by the procedure described in 6.1 – 6.7 is the upper (maximum) pour point. If required, determine the lower (minimum) pour point by heating the sample while stirring, to 105 °C, pouring it into the jar, and determining the pour point as described in 6.4 – 6.7 .

7. Calculation and Report

7.1 Add 3 °C to the temperature recorded in 6.7 and report the result as the pour point, ASTM D5346. For black oil, etc., add 3 °C to the temperature recorded in 6.7 and report the result as upper pour point, ASTM D5346, or lower pour point, ASTM D5346, as required.

8. Precision and Bias

8.1 *Lubricating Oils and Distillate and Residual Fuel Oil:*

8.1.1 *Repeatability*—The difference between successive test results, obtained by the same operator using the same apparatus under constant operating conditions on identical test material, would in the long run, in the normal and correct operation of this test method, exceed 3 °C only in one case in twenty. Differences greater than this should be considered suspect.

8.1.2 *Reproducibility*—The difference between two single and independent test results, obtained by different operators working in different laboratories on identical test material, would in the long run, in normal and correct operation of this test method, exceed 6 °C only in one case in twenty. Differences greater than this should be considered suspect.

8.2 *Bias*—There being no criteria for measuring bias in these test-product combinations, no statement of bias can be made.

8.3 The precision statements were prepared with data on ten new (unused) mineral oil based lubricants and sixteen assorted fuel oils tested by twelve cooperators. The mineral oil based lubricants had pour points ranged from – 48 °C to – 6 °C while the fuel oils had pour points ranging from – 33 °C to + 51 °C. The following precision data were obtained:

95 % Confidence	Mineral Oil Lubricants	Fuel Oils
Repeatability, °C	2.87	2.52
Reproducibility, °C	6.43	6.59

9. Keywords

9.1 fatliquors; leather; petroleum oil pour point; softening and stuffing compounds