



Standard Test Method for Heat and Visible Smoke Release Rates for Materials and Products Using a Thermopile Method¹

This standard is issued under the fixed designation E906/E906M; the number immediately following the designation indicates the year of original adoption or, in the case of revision, the year of last revision. A number in parentheses indicates the year of last reapproval. A superscript epsilon (ϵ) indicates an editorial change since the last revision or reapproval.

1. Scope*

1.1 This test method provides for determining the release rates of heat and visible smoke (**Note 1**) from materials, products, or assemblies when exposed to different levels of radiant heat.

NOTE 1—Visible smoke is described in terms of the obscuration of transmitted light caused by combustion products released during the tests (see 14.2.1).

1.2 This fire-test-response method assesses heat release by a thermal method, thermopile, using a radiant heat source composed of an array of four electrical resistance elements.

1.3 This test method provides for radiant thermal exposure of a specimen both with and without a pilot. Piloted ignition results from direct flame impingement on the specimen (piloted, point ignition) or from use of the pilot to ignite gases evolved by pyrolysis of the specimen.

1.4 Heat and smoke release are measured from the moment the specimen is injected into a controlled exposure chamber. The measurements are continued during the period of ignition (and progressive flame involvement of the surface in the case of point ignition), and to such a time that the test is terminated.

1.5 The apparatus described in this test method is often referred to as the Ohio State University (OSU) rate of heat release apparatus. Configurations A and B are variations on the original design.

1.6 This test method is suitable for exposing essentially planar materials, products or assemblies to a constant, imposed external heat flux that ranges from 0 kW/m² to 80 kW/m².

1.7 The apparatus described in this test method has been used in two configurations. Configuration A is that which is used by the Federal Aviation Administration for assessing materials for aircraft use, at an external heat flux of 35 kW/m²

(DOT/FAA/AR-00/12), while configuration B is suitable, at various incident heat fluxes, for research and development purposes.

1.8 This test method does not provide information on the fire performance of the test specimens under fire conditions other than those conditions specified in this test method. Known limitations of this test method are described in 1.8.1 – 1.8.5.

1.8.1 Heat and smoke release rates depend on a number of factors, including the formation of surface char, the formation of an adherent ash, sample thickness, and the method of mounting.

1.8.2 Heat release values are a function of the specific specimen size (exposed area) tested. Results are not directly scaleable to different exposed surface areas for some products.

1.8.3 The test method is limited to the specified specimen sizes of materials, products, or assemblies. If products are to be tested, the test specimen shall be representative of the product in actual use. The test is limited to exposure of one surface; the options for exposed surface are vertical and horizontal facing up.

1.8.4 At very high specimen heat release rates, it is possible that flaming is observed above the stack, which makes the test invalid.

1.8.5 No general relationship has been established between heat release rate values obtained from horizontally and vertically oriented specimens. Specimens that melt and drip in the vertical orientation shall be tested horizontally.

1.9 The values stated in either SI units or inch-pound units are to be regarded separately as standard. The values stated in each system may not be exact equivalents; therefore, each system shall be used independently of the other. Combining values from the two systems may result in non-conformance with the standard.

1.10 Fire testing involves hazardous materials, operations, and equipment. See Section 6.

1.11 *This standard is used to measure and describe the response or materials, products, or assemblies to heat and flame under controlled conditions, but does not by itself incorporate all factors required for fire hazard or fire risk*

¹ This test method is under the jurisdiction of ASTM Committee E05 on Fire Standards and is the direct responsibility of Subcommittee E05.21 on Smoke and Combustion Products.

Current edition approved Dec. 1, 2021. Published January 2022. Originally approved in 1983. Last previous edition approved in 2017 as E906 – 17. DOI: 10.1520/E0906-21.

*A Summary of Changes section appears at the end of this standard

assessment of the materials, products, or assemblies under actual fire conditions.

1.12 This standard does not purport to address all of the safety concerns, if any, associated with its use. It is the responsibility of the user of this standard to establish appropriate safety, health, and environmental practices and determine the applicability of regulatory limitations prior to use.

1.13 Fire testing is inherently hazardous. Adequate safeguards for personnel and property shall be employed in conducting these tests.

1.14 This international standard was developed in accordance with internationally recognized principles on standardization established in the Decision on Principles for the Development of International Standards, Guides and Recommendations issued by the World Trade Organization Technical Barriers to Trade (TBT) Committee.

2. Referenced Documents

2.1 ASTM Standards:²

D618 Practice for Conditioning Plastics for Testing

E176 Terminology of Fire Standards

E1354 Test Method for Heat and Visible Smoke Release Rates for Materials and Products Using an Oxygen Consumption Calorimeter

2.2 ISO Standard:

ISO 13943 Fire Safety-Vocabulary³

2.3 Federal Aviation Administration Standard:

Aircraft Material Fire Test Handbook, DOT/FAA/AR-00/12, FAA Technical Center, April 2000⁴

3. Terminology

3.1 Definitions—For definitions of terms used in this test method refer to the terminology contained in Terminology E176 and ISO 13943, Fire Safety-Vocabulary. In case of conflict, the definitions given in Terminology E176 shall prevail.

3.2 Definitions of Terms Specific to This Standard:

3.2.1 continuous, as related to data acquisition, adj—conducted at data collection intervals of 5 s or less.

3.2.2 exposed surface, *n*—that surface of the specimen subjected to the incident heat.

3.2.3 gas phase ignition, *n*—ignition of pyrolysis products leaving a heated surface by a pilot flame or other ignition source that does not impinge on, nor significantly affect, for example, by reradiation, the heated surface.

3.2.4 orientation, *n*—plane in which the exposed face of the specimen is located during testing, either vertical or horizontally face upwards.

² For referenced ASTM standards, visit the ASTM website, www.astm.org, or contact ASTM Customer Service at service@astm.org. For Annual Book of ASTM Standards volume information, refer to the standard's Document Summary page on the ASTM website.

³ Available from International Standardization Organization, P.O. Box 56, CH-1211, Geneva 20, Switzerland.

⁴ Available from National Technical Information Service (NTIS), Springfield, VA 22161. An electronic version of the handbook with the latest revisions can be found at the FAA website: <http://www.fire.tc.faa.gov/handbook.stm>.

3.2.5 SMOKE unit, *n*—the concentration of smoke particulates in a cubic metre of air that reduces the percent transmission of light through a 1 m path to 10 %. SMOKE = Standard Metric Optical Kinetic Emission.

3.2.6 time to ignition, *n*—time between the start of the test and the presence of a flame on or over most of the specimen surface for a period of at least 4 s.

4. Summary of Test Method

4.1 The specimen to be tested is injected into an environmental chamber through which a constant flow of air passes. The specimen's exposure is determined by a radiant heat source adjusted to produce the desired total heat flux on the specimen. Exposure options include: horizontal or vertical orientations; nonpiloted ignition, piloted ignition of evolved gases, or point ignition of the surface. The changes in temperature and optical density of the gas leaving the chamber are monitored, and from this data the release rates of heat and visible smoke (see 14.2.1) are calculated.

5. Significance and Use

5.1 This test method provides a description of the behavior of material specimens under a specified fire exposure in terms of the release rate of heat and visible smoke. It is possible to determine the change in behavior of materials and products with change in heat-flux exposure by testing specimens in a series of exposures that cover a range of heat fluxes.

5.2 The data obtained for a specific test describe the rate of heat and smoke release of the specimen when exposed to the specific environmental conditions and procedures used in performing that test.

5.3 The entire exposed surface of the specimen will not be burning during the progressive involvement phase when piloted, point ignition (impingement) procedures are used. During the period of progressive surface involvement, release rates of heat and smoke are “per square metre of original exposed surface area” not “per square metre of flame involved surface.”

5.4 The rates of both heat and smoke release are calculated per square metre of original surface area exposed. If a specimen swells, sags, delaminates, or otherwise deforms so that the exposed surface area changes, calculated release rates correspond to the original area, not to the new surface area.

5.5 Heat-release values depend on mode of ignition. Gas phase ignition gives a more dimensionally consistent measure of release rate when very rapid or immediate flame involvement of the specimen surface occurs. However, piloted, point ignition allows release-rate information to be obtained at external heat flux from zero up to that required for satisfactory gas-phase ignition, usually over 20 kW/m² external exposure. No correlation between the two modes of piloted ignition has been established.

5.6 Release rates depend on many factors, some of which cannot be controlled. It is possible that samples that produce a surface char, a layer of adherent ash, or those that are composites or laminates do not attain a steady-state release rate. Thermally thin specimens, that is, specimens whose

unexposed surface changes temperature during period of test, will not attain a steady-state release rate. Therefore, release rates for a given material will depend, for example, on how the material is used, its thickness, and the method of mounting.

5.7 Heat-release values are for the specific specimen size (exposed area) tested. Results are not directly scalable to different exposed surface areas for some products.

5.8 The method is limited to specimen sizes of materials in accordance with 7.1 and to products from which it is possible to obtain a test specimen representative of the product in actual use. The test is limited to exposure of one surface; there are two options for exposure orientation: either vertical or horizontal. If a heat release rate of 8 kW, which is equivalent to 355 kW/m² for 150 mm [6-in.] by 150 mm [6-in.] vertical specimens, or 533 kW/m² for 100 mm [4-in.] by 150 mm [6-in.] horizontal specimens is exceeded, there is danger of combustion occurring above the stack.

5.9 No general relationship between release rate values obtained from horizontally and vertically oriented specimens has been established. Conduct tests on specimens in the form in which the material is oriented in end use conditions. To provide additional information, conduct tests in the horizontal orientation for those specimens that melt and drip in the vertical orientation.

5.10 Release rate measurements provide useful information for product development by giving a quantitative measure of specific changes in fire test performance caused by product modifications.

5.11 This test method differs in both the method of exposure and the calculation procedure from the techniques used in Test Method E1354, the cone calorimeter, which assesses heat release by oxygen consumption calorimetry, using a truncated cone as a radiant source.

6. Operator Safety

6.1 The test procedure involves high temperatures, and combustion processes. Therefore, it is possible for eye injuries, burns, ignition of extraneous objects or clothing, and inhalation of smoke or combustion products to occur, unless proper precautions are taken. To avoid accidental leakage of toxic combustion products into the surrounding atmosphere, it is advisable to evacuate the chamber, at the end of a test, into an exhaust system with adequate capacity. The operator must use heavy gloves, safety tongs or other suitable protection for removal of the specimen holder. The venting must be checked periodically for proper operation. Care shall be taken not to touch the spark igniter during operation, if used, since it carries a substantial potential. The exhaust system of the apparatus shall be checked for proper operation before testing and shall discharge into a building exhaust system with adequate capacity. The possibility of the violent ejection of molten hot material or sharp fragments from some kinds of specimens when irradiated must be taken into account.

7. Sample Preparation

7.1 The standard size for vertically mounted specimens is 150 mm ± 2 mm by 150 mm ± 2 mm [5.94 in. +0 in., -0.06 in.

by 5.94 in. +0 in., -0.06 in.] exposed surface with thickness up to 100 mm [4.0 in.]. The standard size for horizontally mounted specimens is 150 mm ± 2 mm by 150 mm ± 2 mm [5.94 in. +0 in., -0.06 in. by 5.94 in. +0 in., -0.06 in.] exposed surface, up to 45 mm [1.75 in.] thick. Mount thin specimens, such as wall or floor coverings, in the same manner as used. For example, test a wall covering to be glued to gypsum wall board when glued to a section of gypsum board using the same type of adhesive. The assembly shall be considered the specimen to be tested. Applications requiring thicknesses greater than 45 mm [1.75 in.] shall be tested at 45 mm [1.75 in.] thicknesses.

7.2 *Conditioning*—Condition the specimens at 23 °C ± 3 °C [70 °F ± 5 °F] and 50 % ± 5 % relative humidity for a minimum of 24 h prior to test, or as described by Procedure A of Practice D618, if appropriate.

7.3 *Mounting*—Expose only one surface of a specimen during a test. Insulate, on five sides, specimens that have a slab geometry. A single layer of 0.03 mm ± 0.01 mm [0.0012-in. ± 0.005-in.] aluminum foil shall be wrapped tightly on all unexposed sides with the dull side of the foil facing the specimen surface. For products whose exposed surface is not a plane, describe mounting and method of calculating surface area exposed when reporting results.

7.4 *Specimen Orientation*—For specimens with anisotropic properties (meaning they have different properties in different directions such as machine and cross-machine directions for extrusions, wrap and fill for woven fabrics), the specimens shall be tested in the orientation giving the highest results. If this orientation is not known prior to test, two sets of at least three specimens each shall be prepared and tested, with one set oriented in one direction and the second set oriented in the other direction.

8. Release Rate Apparatus—Configuration A

8.1 The apparatus shown in Figs. 1 and 2 shall be used to determine heat release rates. All exterior surfaces of the apparatus, except the holding chamber, shall be insulated with 25 mm ± 1 mm [1 in. ± 0.04 in.] thick, low-density, high-temperature, fiberglass board insulation.^{5,6} A gasketed door, through which the sample injection rod slides, shall be provided to form an airtight closure on the specimen hold chamber.

8.2 *Thermopile*—The temperature difference between the air entering the environmental chamber and that leaving shall be monitored by a thermopile having 5 hot and 5 cold 24-gauge chromel-alumel junctions. The loop to be formed by the thermocouple junction shall be 1.3 mm ± 0.3 mm [0.050 in. ± 0.010 in.] in diameter. The cold junctions shall be located in the

⁵ Owens-Corning Flat Duct Board, Type 475-FR, density 65 kg/m³ [4 lb/ft³], thermal conductivity 0.033 W/(m²K) [10 Btu/(ft² min)], 25 mm [1 in.] thick, or its equivalent.

⁶ The sole source of supply of the apparatus known to the committee at this time is Owens-Corning, Granville, OH. If you are aware of alternative suppliers, please provide this information to ASTM Headquarters. Your comments will receive careful consideration at a meeting of the responsible technical committee,¹ which you may attend.

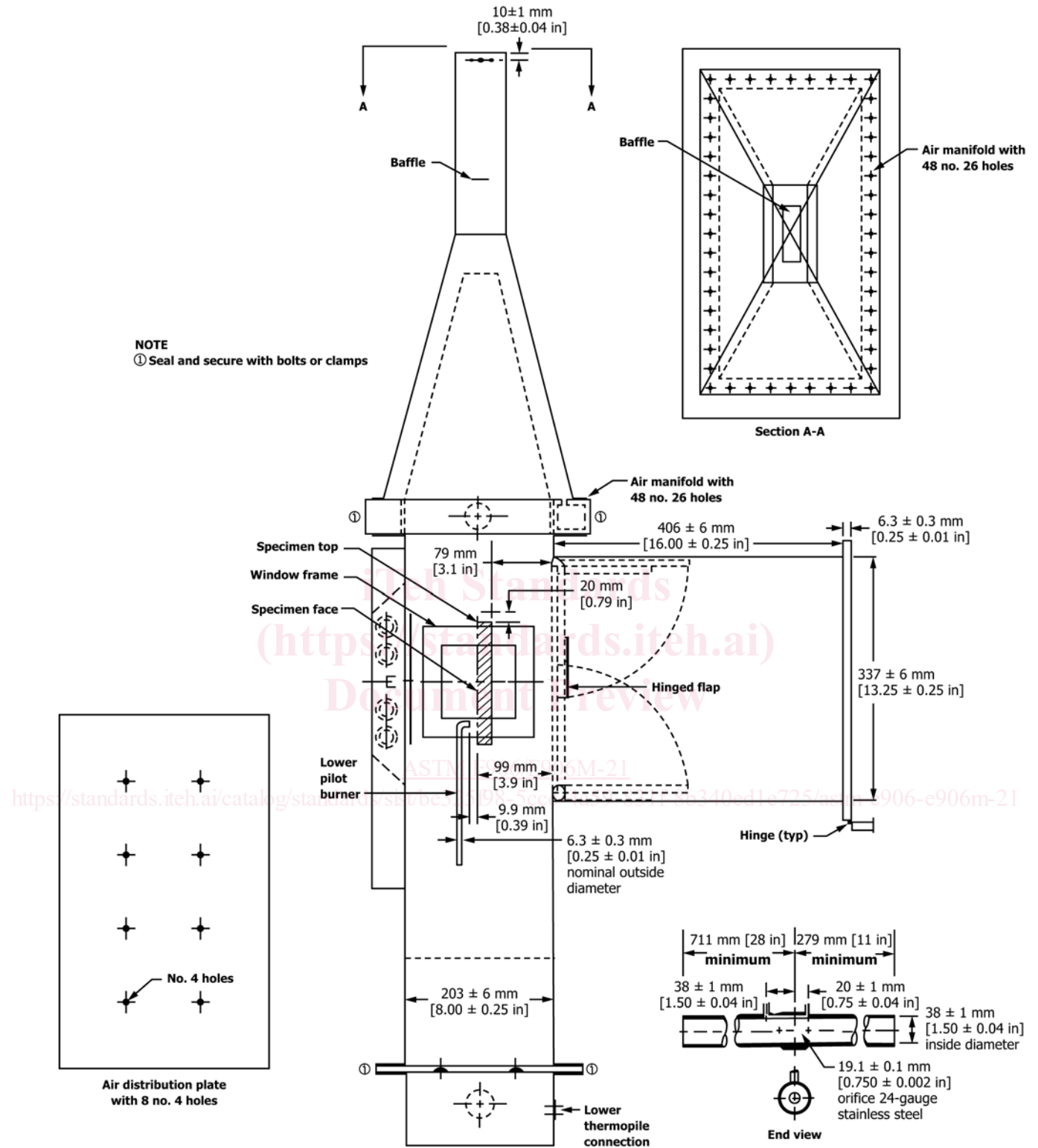

FIG. 1 Rate of Heat Release Apparatus—Example 1

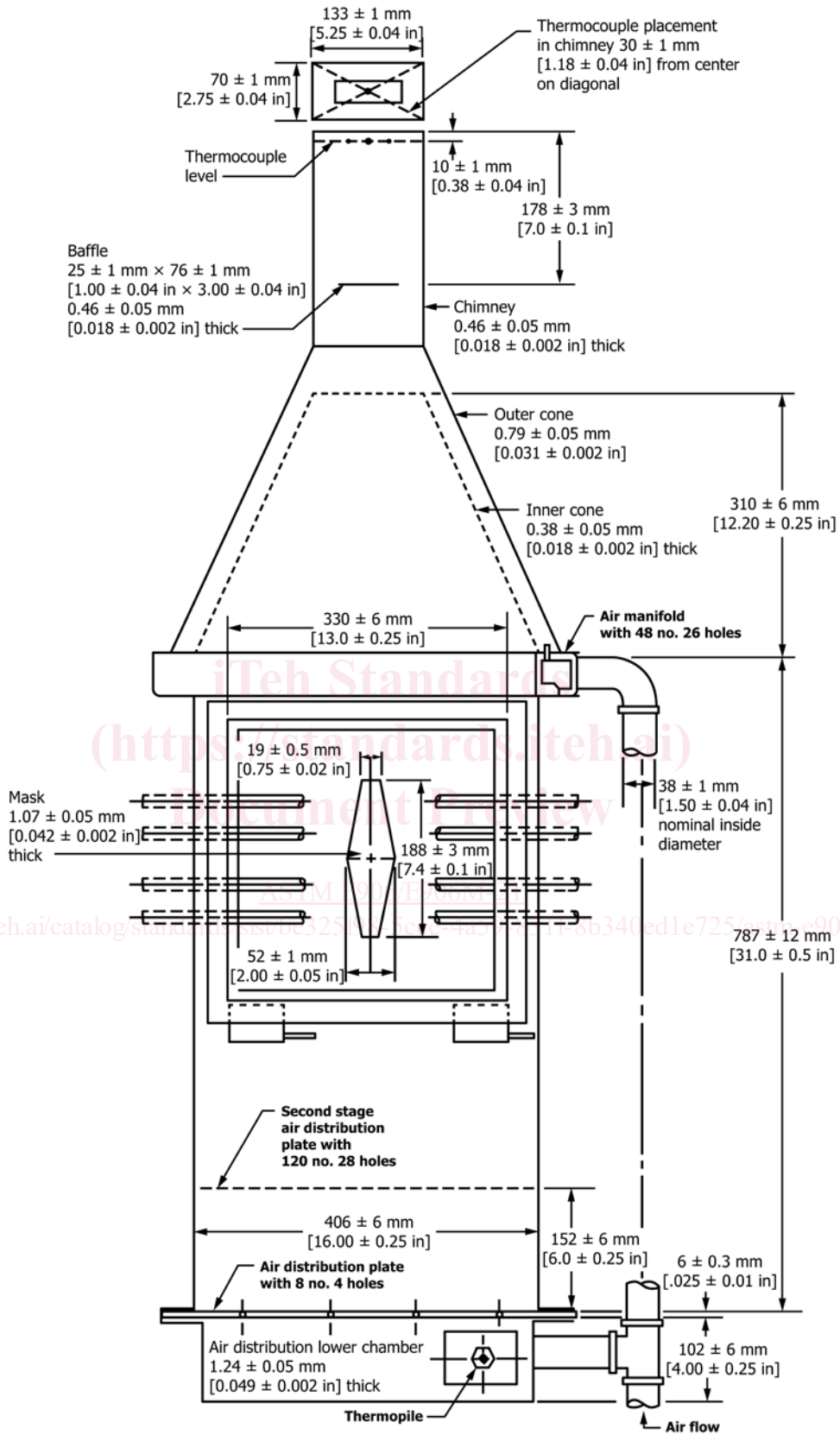

FIG. 2 Rate of Heat Release Apparatus—Example 2

pan below the air distribution plate (see 8.4). The hot junctions shall be located $10\text{ mm} \pm 1\text{ mm}$ [$0.38\text{ in.} \pm 0.04\text{ in.}$] below the top of the chimney. One of the hot junctions shall be placed at the center of the chimney's cross section, and the other four shall be placed on the chimney diagonals $30\text{ mm} \pm 1\text{ mm}$ [$1.18\text{ in.} \pm 0.04\text{ in.}$] from the center thermocouple.

8.3 Radiant Heat Source—A radiant heat source for generating a heat flux of up to 80 kW/m^2 , using four silicon carbide elements Type LL, $508\text{ mm} \pm 3\text{ mm}$ [$20\text{ in.} \pm 0.1\text{ in.}$] by $16\text{ mm} \pm 1\text{ mm}$ [$0.63\text{ in.} \pm 0.04\text{ in.}$], with a nominal resistance of $1.4\ \Omega$, as shown in Figs. 1-3, shall be used. The silicon carbide elements shall be mounted in the stainless steel panel box by inserting them through $16\text{ mm} \pm 1\text{ mm}$ [$0.63\text{ in.} \pm 0.04\text{ in.}$] holes in $0.9\text{ mm} \pm 0.1\text{ mm}$ [$0.03\text{-in.} \pm 0.004\text{-in.}$] thick ceramic fiber or calcium-silicate millboard. Locations of the holes in the pads and stainless steel covered plates shall be as shown in Fig. 3. A truncated diamond-shaped mask constructed of $1.07\text{ mm} \pm 0.05\text{ mm}$ [$0.042\text{ in.} \pm 0.002\text{ in.}$] stainless steel shall be added to provide uniform heat flux density over the area occupied by the vertical specimen. An adjustable power supply capable of producing 12.5 kVA shall be provided. The heat flux density over the specimen surface when set at 35 kW/m^2 shall be uniform within 5 %, and shall be checked periodically and after each heating element change. Uniformity of heat flux density shall be determined by calorimeter measurements at the center and at the four corners of the specimen surface.

8.4 Air Distribution System—The air entering the apparatus shall be $21\text{ }^\circ\text{C}$ to $24\text{ }^\circ\text{C}$ [$70\text{ }^\circ\text{F}$ to $75\text{ }^\circ\text{F}$] in temperature and set at approximately $0.04\text{ m}^3/\text{s} \pm 0.01\text{ m}^3/\text{s}$ [$85\text{ ft}^3/\text{min} \pm 20\text{ ft}^3/\text{min}$] using an orifice meter. The orifice meter shall be comprised of a square-edged circular plate orifice, $0.5\text{ mm} \pm 0.1\text{ mm}$ [$0.020\text{ in.} \pm 0.004\text{ in.}$] thick, located in a circular pipe with a diameter of $38\text{ mm} \pm 1\text{ mm}$ [$1.50\text{ in.} \pm 0.04\text{ in.}$], with two pressure measuring points located $38\text{ mm} \pm 1\text{ mm}$ [$1.50\text{ in.} \pm 0.04\text{ in.}$] above and $20\text{ mm} \pm 1\text{ mm}$ [$0.75\text{ in.} \pm 0.04\text{ in.}$] below the orifice and connected to a mercury manometer. The inlet pipe shall remain $38\text{ mm} \pm 1\text{ mm}$ [$1.50\text{ in.} \pm 0.04\text{ in.}$] in diameter (Fig. 1).

8.4.1 The air entering the environmental chamber shall be distributed by a $6.3\text{ mm} \pm 2\text{ mm}$ [$0.25\text{ in.} \pm 0.04\text{ in.}$] thick aluminum plate having eight $5.3\text{ mm} \pm 0.03\text{ mm}$ [$0.209\text{-in.} \pm 0.001\text{-in.}$] drill holes (ANSI No. 4 drill holes), $51\text{ mm} \pm 1\text{ mm}$ [$2.0\text{ in.} \pm 0.04\text{ in.}$] from the sides on $102\text{ mm} \pm 2\text{ mm}$ [$4\text{ in.} \pm 0.08\text{ in.}$] centers, mounted at the base of the environmental chamber. A second plate having 120 evenly spaced, $3.6\text{ mm} \pm 0.03\text{ mm}$ [$0.140\text{-in.} \pm 0.001\text{-in.}$] drill holes (ANSI No. 28 drill holes) shall be mounted $152\text{ mm} \pm 2\text{ mm}$ [$6\text{ in.} \pm 0.08\text{ in.}$] above the aluminum plate (Fig. 2).

8.4.2 The air supply manifold at the base of the pyramidal section shall have 48 evenly spaced, $3.7\text{ mm} \pm 0.03\text{ mm}$ [$0.147\text{-in.} \pm 0.001\text{-in.}$] drill holes (ANSI No. 26 drill holes) $10\text{ mm} \pm 1\text{ mm}$ [$0.38\text{ in.} \pm 0.04\text{ in.}$] from the inner edge of the manifold, resulting in an airflow split of approximately three to one within the apparatus (Fig. 1).

8.5 Exhaust Stack—An exhaust stack, $133\text{ mm} \pm 1\text{ mm}$ by $70\text{ mm} \pm 1\text{ mm}$ [$5.25\text{ in.} \pm 0.04\text{ in.}$ by $2.75\text{ in.} \pm 0.04\text{ in.}$] in

cross section, and $254\text{ mm} \pm 1\text{ mm}$ [$10\text{ in.} \pm 0.04\text{ in.}$] long, fabricated from stainless steel, shall be mounted on the outlet of the pyramidal section (see Figs. 1 and 2). A $25\text{ mm} \pm 1\text{ mm}$ by $76\text{ mm} \pm 1\text{ mm}$ [$1\text{ in.} \pm 0.04\text{ in.}$ by $3\text{ in.} \pm 0.04\text{ in.}$] plate of $0.46\text{ mm} \pm 0.05\text{ mm}$ [$0.018\text{ in.} \pm 0.002\text{ in.}$] stainless steel shall be centered inside the stack, perpendicular to the airflow, $76\text{ mm} \pm 1\text{ mm}$ [$3\text{ in.} \pm 0.04\text{ in.}$] above the base of the stack.

8.6 Specimen Holders—Specimen holders shall be fabricated of stainless steel sheet $0.46\text{ mm} \pm 0.05\text{ mm}$ [$0.018\text{ in.} \pm 0.002\text{ in.}$] thick as shown in Fig. 4. Specimen holders shall be attached to the injection rod using the support shown in Fig. 4. Each holder shall be provided with a “V”-shaped spring pressure plate. The position of the spring pressure plate shall be capable of being changed to accommodate different specimen thicknesses by inserting the retaining rod in different holes of the specimen holder frame. Each holder shall also have two wires attached to the front of the holder to secure the face of the specimen in the holder.

8.6.1 Drip Pan—A drip pan shall be fabricated of stainless steel sheet $0.46\text{ mm} \pm 0.05\text{ mm}$ [$0.018\text{ in.} \pm 0.002\text{ in.}$] thick as shown in Fig. 4 and be attached to the specimen holder using the flanges shown in Fig. 4. Line the drip pan with aluminum foil, to facilitate cleaning after a test.

NOTE 2—Drip pans are required to prevent melting specimens from dripping into the lower pilot burner.

8.7 Calorimeter—A water-cooled, total heat flux density, foil-type Gardon gauge calorimeter shall be used to measure the total heat flux density at a point where the center of the specimen surface is located at the start of the test. When positioned to measure flux density, the sensing surface of the meter shall be flush with the supporting device surface so that air heated by such a support does not contact the sensing surface of the meter.

8.8 Pilot Burners—Pilot burners shall be placed at the bottom and top of the specimens. The burners shall be constructed of stainless steel tubing with a $6\text{ mm} \pm 1\text{ mm}$ [$0.25\text{ in.} \pm 0.04\text{ in.}$] outside diameter (OD) and $0.8\text{ mm} \pm 0.1\text{ mm}$ [$0.03\text{ in.} \pm 0.004\text{ in.}$] wall thickness.

8.8.1 Lower Pilot Burner—The lower pilot burner shall be located as shown in Fig. 1. The lower pilot burner shall have its centerline perpendicular to the surface of the specimen and $5\text{ mm} \pm 1\text{ mm}$ [$0.19\text{ in.} \pm 0.04\text{ in.}$] above the specimen's lower exposed edge, and shall have its end $10\text{ mm} \pm 1\text{ mm}$ [$0.38\text{ in.} \pm 0.04\text{ in.}$] from the specimen's surface. A methane-air mixture shall be used consisting of $120\text{ cm}^3/\text{min} \pm 10\text{ cm}^3/\text{min}$ [$0.0040\text{ ft}^3/\text{min} \pm 0.0003\text{ ft}^3/\text{min}$] (at standard temperature and pressure) methane (99 % minimum purity) and an air supply, adjusted to produce a flame such that the inner cone is approximately the same length as the diameter of the flame.

8.8.2 Spark Igniter—A spark igniter shall be installed to ensure that the lower pilot burner remains burning. A test is invalidated if the lower pilot burner becomes extinguished for any period that exceeds 3 s. A circuit for a satisfactory device is sketched in Fig. 5.

8.8.3 Upper Pilot Burner—An upper pilot burner shall be provided to produce flamelets above the test specimen to ignite flammable gases. If any of the flamelets on the upper pilot

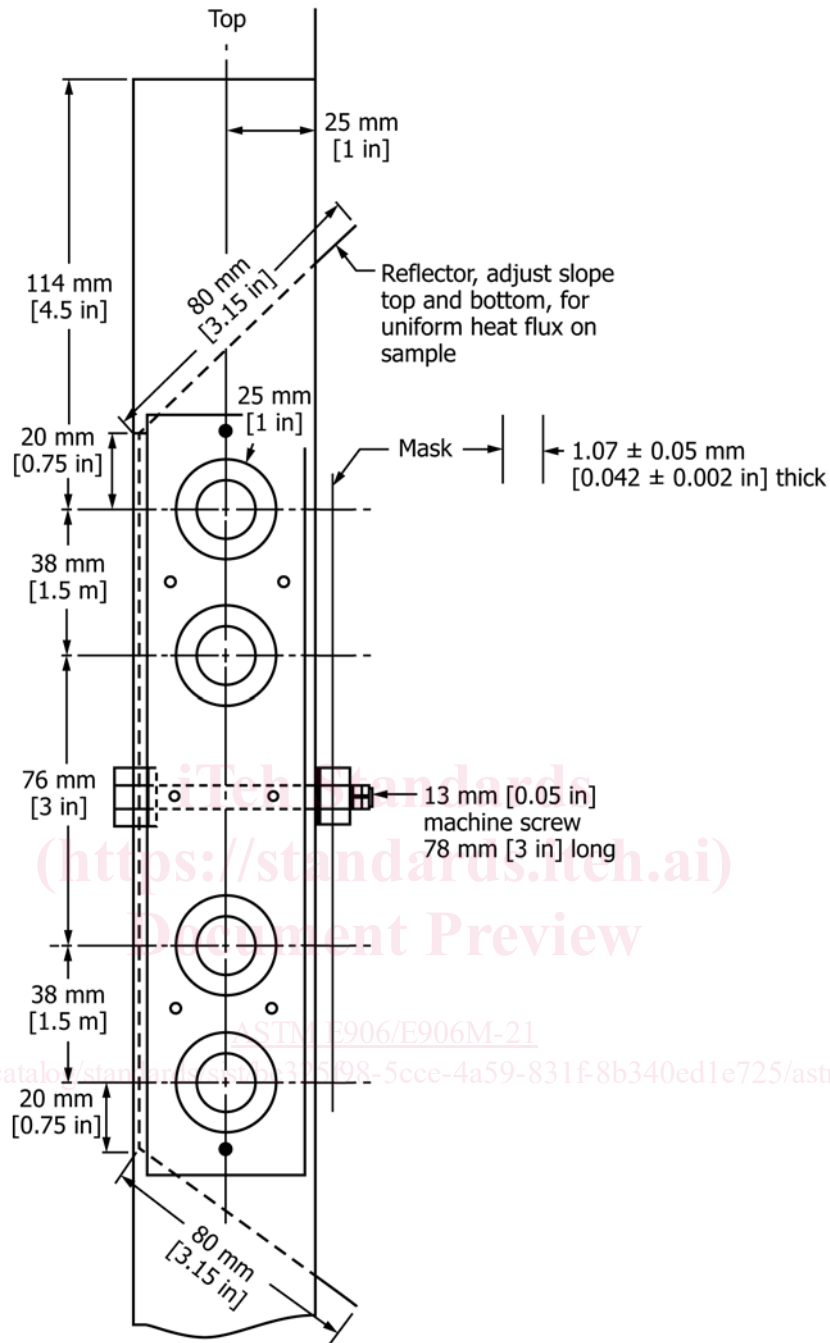

FIG. 3 Side View—Globar Radiant Heat Panel

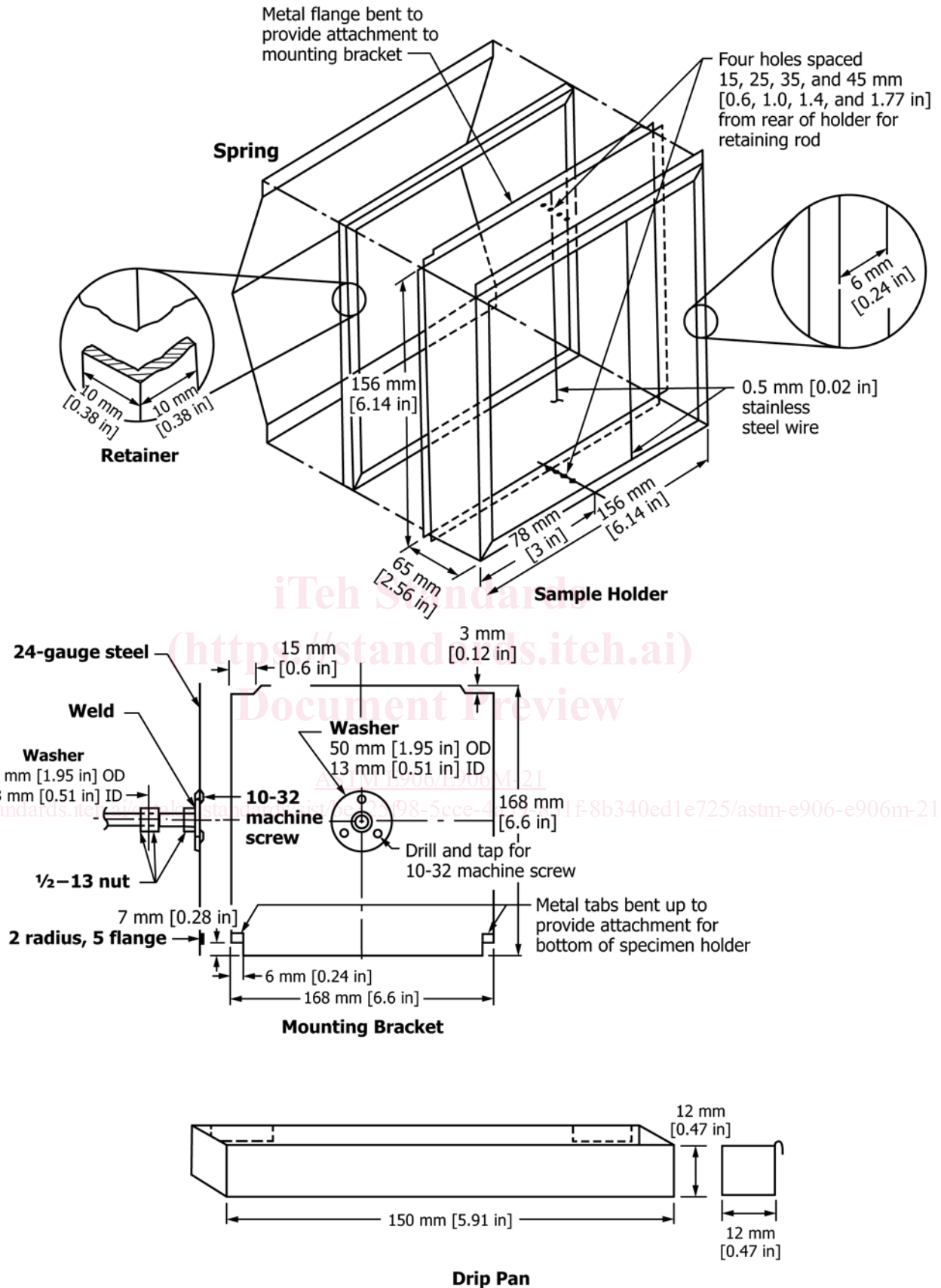

FIG. 4 Heat Release Specimen Holder, Mounting Bracket, and Drip Pan

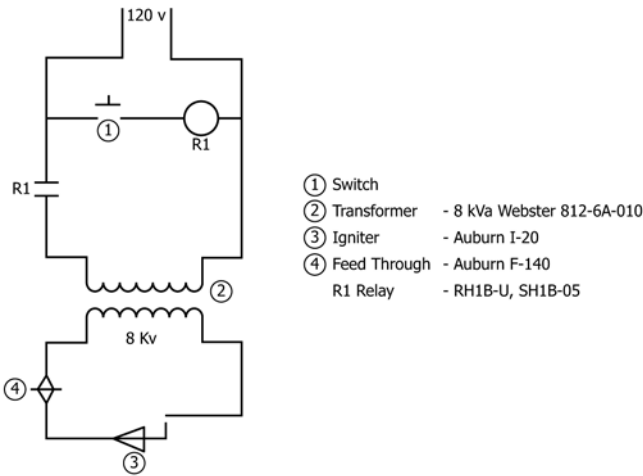

FIG. 5 Lower Pilot Burner Igniter Schematic

burner extinguishes for a period longer than 3 s during the test, the test is invalidated. The upper pilot burner shall be constructed from a piece of stainless steel tubing with an OD of $6\text{ mm} \pm 1\text{ mm}$ [$0.25\text{ in.} \pm 0.04\text{ in.}$] and a wall thickness of $0.8\text{ mm} \pm 0.1\text{ mm}$ [$0.03\text{ in.} \pm 0.004\text{ in.}$]. The diameter hole drilled $10\text{ mm} \pm 1\text{ mm}$ [$0.38\text{ in.} \pm 0.04\text{ in.}$] above the upper edge of the window frame, and be supported and positioned by an adjustable Z-shaped bracket mounted outside the environmental chamber above the viewing window. The tubing shall be located $20\text{ mm} \pm 1\text{ mm}$ [$0.79\text{ in.} \pm 0.04\text{ in.}$] above and $20\text{ mm} \pm 1\text{ mm}$ [$0.79\text{ in.} \pm 0.04\text{ in.}$] behind the upper front edge of the specimen holder, and installed such that the holes are directed horizontally toward the radiant heat source. One end of the tubing shall be closed with a silver solder plug or equivalent.

8.8.4 *Standard Three-Hole Burner*—The standard three-hole upper pilot burner shall be constructed from a piece of $6\text{ mm} \pm 1\text{ mm}$ [$0.25\text{ in.} \pm 0.04\text{ in.}$] OD tubing $360\text{ mm} \pm 10\text{ mm}$ [$14\text{ in.} \pm 0.4\text{ in.}$] long. Three $2.5\text{ mm} \pm 0.1\text{ mm}$ [$0.098\text{ in.} \pm 0.004\text{ in.}$] diameter drill holes (ANSI No. 40 drill holes), each radiating in the same direction, shall be drilled into the tubing. The holes shall be spaced $60\text{ mm} \pm 1\text{ mm}$ [2.4 in.]

$\pm 0.04\text{ in.}$] apart, with the first hole located $5\text{ mm} \pm 1\text{ mm}$ [$0.19\text{ in.} \pm 0.04\text{ in.}$] from the closed end, as is shown in Fig. 6. The burner shall be positioned above the specimen holder so that the middle hole lies in the plane perpendicular to the exposed surface of the specimen and passes through its vertical centerline. The burner fuel shall be methane of 99 % minimum purity. The fuel flow rate shall be adjusted to produce flamelets 25 mm [1 in.] in length that bend upwards slightly above the burner tube.

8.8.5 *Optional Fourteen-Hole Burner*—An optional burner that has been found satisfactory is as follows; this burner has a greater probability of reigniting flamelets which become extinguished during a test. Fourteen $1.04\text{ mm} \pm 0.01\text{ mm}$ [$0.041\text{ in.} \pm 0.0005\text{ in.}$] drill holes (ANSI No. 59 drill holes), each radiating in the same direction, shall be drilled into a $381\text{ mm} \pm 10\text{ mm}$ [$15\text{ in.} \pm 0.4\text{ in.}$] length of nominally 7 mm [0.25 in.] tubing. The holes shall be spaced $13\text{ mm} \pm 1\text{ mm}$ [$0.5\text{ in.} \pm 0.04\text{ in.}$] apart with the first hole located $13\text{ mm} \pm 1\text{ mm}$ [$0.5\text{ in.} \pm 0.04\text{ in.}$] from the closed end, as shown in Fig. 7. The burner shall be positioned above the specimen holder so that the holes are placed above the specimen holder as shown in Fig. 7. The fuel fed to this burner shall be methane of 99 % minimum purity mixed with air in a ratio of approximately 50/50 by volume. The total fuel flow shall be adjusted to provide flamelets 25 mm [1 in.] long. When the gas/air ratio and its fuel flow rate are properly adjusted, approximately 6 mm [0.25 in.] of the flame length appears yellow in color.

9. Calibration of Equipment—Configuration A

9.1 *Calibration Burner*—A calibration burner as shown in Fig. 8 shall be provided that fits over the end of the pilot flame tubing with a gas-tight connection.

9.2 *Calibration Gas*—Methane of at least 99 % purity shall be used for calibration purposes.

9.3 *Wet Test Meter*—A wet test meter accurate to 0.2 L/min [$0.007\text{ ft}^3/\text{min}$] shall be provided to measure the gas flow rate to the calibration burner. Prior to usage, the wet test meter shall be leveled and filled with distilled water to the tip of the internal pointer.

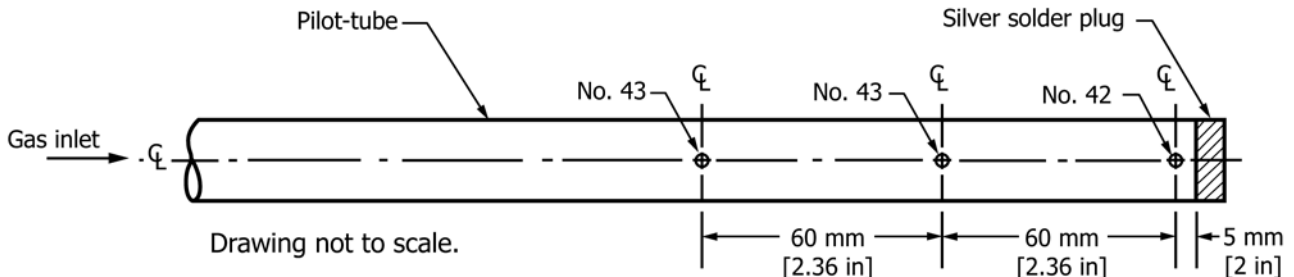

Wet Test Meter Measurements

Methane: 730 cc/min @ 29°C/738.2 torr
Air: 750 cc/min @ 29°C/738.2 torr

Pilot Tube

Type 304 SS
I.D.: 4.5 mm [0.18 in]
I.D.: 6.5 mm [0.26 in]
Length: approx. 400 mm [15.7 in]

FIG. 6 Upper Pilot Tube-Outlet Hole Sizes and Configurations

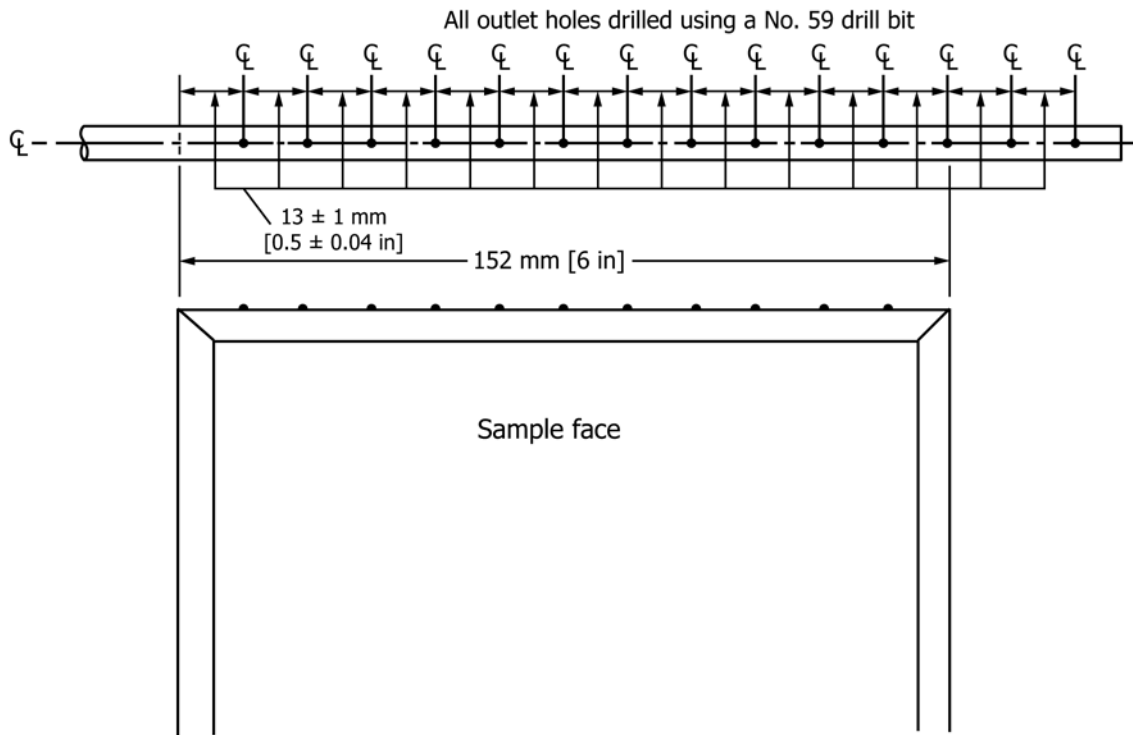
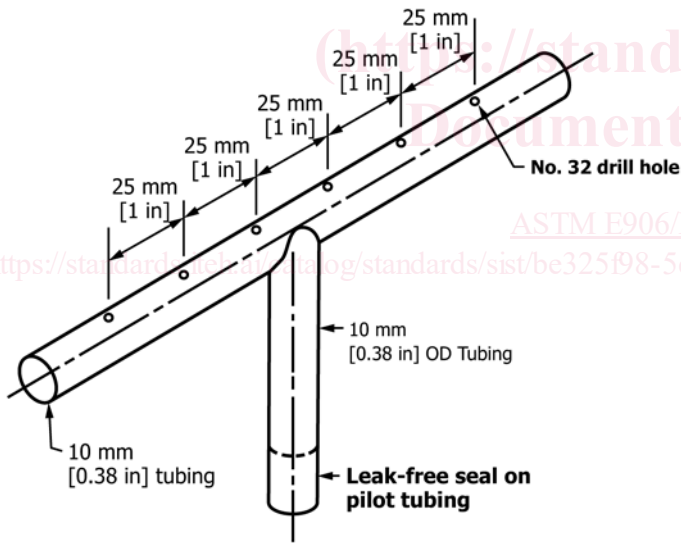

FIG. 7 Modification of the Upper Pilot Tube for the OSU Chamber



(Unless denoted otherwise, all dimensions are in millimeters.)

FIG. 8 Calibration Burner—Configuration A

9.4 Calibration Gas Manifold:

9.4.1 A manifold shall be provided upstream of the wet test meter to control calibration gas flow. The manifold shall have four flow orifices controlled by needle valves that are preset to provide calibration gas at approximate (uncorrected for the presence of water vapor) flow rates of 1 L/min, 4 L/min, 6 L/min, and 8 L/min [0.035 ft³/min, 0.140 ft³/min, 0.210 ft³/min, and 0.280 ft³/min] as indicated by revolution rate (measured by a stop watch accurate to 1 s) of the wet test meter. Output from each of the four flow orifices shall be controlled by a toggle on/off valve, and be plumbed into a single flow line

so that the calibration gas flow rate to the calibration burner can be set at either 1 L/min, 4 L/min, 6 L/min, or 8 L/min [0.035 ft³/min, 0.140 ft³/min, 0.210 ft³/min, or 0.280 ft³/min].

9.4.2 The actual corrected value, *F*, of each of the flow rates shall be determined to an accuracy of 0.2 L/min [0.007 ft³/mm], and these corrected values used for calibration calculations of heat release rate.

9.5 Calibration Procedure:

9.5.1 Replace the lower pilot burner with the calibration burner shown in Fig. 8.

9.5.2 Install the wet test meter. Ensure it is leveled and filled with distilled water. Ambient temperature and pressure of the water are based on the internal wet test meter temperature.

9.5.3 Turn on the air distribution system.

9.5.4 Turn on the radiant heat source and ensure that the heat flux density is 35.0 kW/m² ± 0.5 kW/m².

9.5.5 Using the calibration gas manifold, set the baseline flow rate of 1 L/min [0.035 ft³/min] of methane to the calibration burner, and light the burner. Measure the thermopile baseline voltage.

9.5.6 Immediately prior to recording the thermopile outputs in 9.5.7, precondition the chamber at a methane flow rate of 8 L/min [0.280 ft³/min]. Do not record the thermopile output for this step as part of calibration.

9.5.7 Increase the gas flow to the burner to a higher flow rate and then decrease to the baseline flow rate. After 2 mm of burning at each rate, monitor the thermopile output (millivolts) for a 10-s period, and record the average reading and decrease flow rate to the baseline flow of 1 L/min [0.035 ft³/min]. This sequence of increasing and decreasing the methane flow rate is

as follows: 1 - 4 - 1 - 6 - 1 - 8 - 1 - 6 - 1 - 4 L/min [0.035 - 0.140 - 0.035 - 0.210 - 0.035 - 0.280 - 0.035 - 0.210 - 0.035 - 0.140 ft³/min].

9.6 Compute the calibration factor for each upward rate step (that is: 1-4, 1-6, 1-8, 1-6, 1-4 L/min) according to the following formula:

$$k_h = 25.31 \cdot \frac{273}{T_a} \cdot \frac{(P - P_y)}{760} \cdot \frac{(F - F_0)}{(V_1 - V_0)} \cdot [\text{kW mV/m}^2] \quad (1)$$

where:

F = corrected upper flow rate of calibration gas, L/min (either 4, 6, or 8),

F_0 = corrected baseline flow rate of methane, L/min (approximately 1 L/min),

P = ambient atmospheric pressure, mm Hg,

P_y = water vapor pressure of wet test meter water temperature, mm Hg,

T_a = ambient temperature, K,

V_1 = thermopile voltage at upper flow rate, mV, and

V_0 = thermopile voltage at baseline flow rate, mV.

NOTE 3—The constant used in the above equation is derived as follows: 25.31 = (Heat content of methane at STP, 31.176 Btu/L) × (conversion factor of 0.0176 kW-min/Btu) / (area of a specimen, 0.02323 m²).

9.7 Average the five results and compute the percent relative standard deviation. If the percent relative standard deviation is greater than 5 %, repeat the determination. If it is less than 5 %, use the average as the calibration factor.

10. Test Procedure and Calculations—Configuration A

10.1 Set the airflow to the equipment by adjusting the pressure differential across the orifice plate to 200 mm [7.87 in.] mercury.

10.2 Set the power supply to the Globars to produce a radiant flux density of 35.0 kW/m² ± 0.5 kW/m² at the point which the center of the front surface of the specimen will occupy when positioned for test.

10.3 Light the pilot flames and check that their positions are as described in 10.8. Activate the spark igniter if a spark igniter is used.

10.4 Place the specimen in the hold chamber with the radiation shield doors closed. Secure the airtight outer door, and start the recording devices. Hold the specimen in the hold chamber for 60 s ± 10 s.

10.5 Record, at least once per s, the thermopile millivolt output during the final 20 s of the hold time before the specimen is injected and report the average as the baseline thermopile reading (millivolts).

10.6 After recording the baseline reading and within a time frame not exceeding 3 s, open the radiation doors, inject the specimen into the burn chamber, and close the radiation doors. Record thermopile millivolt outputs at least once per s for the duration for the test.

10.7 After the test has run for 5 min, terminate the test and remove the sample.

10.8 Discard data from any test during which the lower pilot burner was extinguished for any period of time exceeding 3 s,

or during which at least one of the upper pilot flamelets was extinguished for any period of time exceeding 3 s.

10.9 Calculate the heat release rate for any point of time from the reading of the thermopile output voltage, V , at that time as heat release rate by the following formula:

$$RHR = k_h \cdot (V - V_0) \quad (2)$$

where k_h and V_0 are the calibration factor and the thermopile millivolt reading at the baseline, respectively.

10.10 Determine and record the maximum heat release rate during the 5-min test.

10.11 Compute and record the total heat released after the first 2 min of testing by integrating the heat release rate versus time curve during the first 2 min.

10.12 Clean the thermopile hot junctions to remove soot after testing each specimen. Do not disturb the position of the thermocouples. Ensure that the thermocouples are in their proper position before proceeding with the next specimen.

NOTE 4—A small soft-bristled brush has been found satisfactory for cleaning the thermocouple junctions. A template facilitates checking thermocouple positioning.

11. Release Rate Apparatus—Configuration B

11.1 *Release Rate Apparatus* (Fig. 9) is used to determine release rates of heat and smoke by this test method. All exterior surfaces of the apparatus, except the holding chamber, shall be insulated with 25 mm thick, low density, high-temperature, fiber glass board insulation.⁶ A gasketed door, through which the sample injection rod slides, forms an airtight closure on the specimen hold chamber.

11.2 *Thermopile*—The temperature difference between the air entering the environmental chamber and that leaving is monitored by a thermopile having five hot and five cold, 24-gauge Chromel-Alumel Type K thermocouple junctions. The loop to be formed by the thermocouple junction shall be 1.4 mm ± 0.3 mm [0.050 in. ± 0.010 in.] in diameter. The cold junctions shall be located in the pan below the air distribution plate. The hot junctions shall be located 10 mm [0.38 in.] below the top of the chimney. One of the hot junctions shall be placed at the center of the chimney's cross section, and the other four shall be placed on the chimney diagonals 30 mm [1.18 in.] from the center of the thermopile (see 11.5). The use of a compensator tab, as described in 11.2.2 through 11.2.5, is not needed if this thermopile is used.

11.2.1 *Thermopile for Research Configuration*—Alternatively, the temperature difference between the air entering the environmental chamber and that leaving is monitored by a thermopile having three hot and three cold, 24-gauge Chromel-Alumel Type K junctions. The hot junctions are spaced across the top of the exhaust stack. Two hot junctions are located 25 mm [1 in.] from each side on diagonally opposite corners and the third in the center of the chimney's cross 14 mm [0.55 in.] below the top of the chimney. The cold junctions are located in the pan below the lower air distribution plate (see 11.5). If this thermopile is used, the use of a thermal inertia compensator, as described in 11.2.2 through 11.2.5, is recommended.