



Designation: ~~D3034~~—16 D3034 – 21

## Standard Specification for Type PSM Poly(Vinyl Chloride) (PVC) Sewer Pipe and Fittings<sup>1</sup>

This standard is issued under the fixed designation D3034; the number immediately following the designation indicates the year of original adoption or, in the case of revision, the year of last revision. A number in parentheses indicates the year of last reappraisal. A superscript epsilon ( $\epsilon$ ) indicates an editorial change since the last revision or reappraisal.

*This standard has been approved for use by agencies of the U.S. Department of Defense.*

### 1. Scope\*

1.1 This specification covers requirements and test methods for materials, dimensions, workmanship, flattening resistance, impact resistance, pipe stiffness, extrusion quality, joining systems and a form of marking for type PSM poly(vinyl chloride) (PVC) sewer pipe and fittings.

1.2 Pipe and fittings produced to this specification should be installed in accordance with Practice [D2321](#).

1.3 The text of this specification references notes, footnotes, and appendixes which provide explanatory material. These notes and footnotes (excluding those in tables and figures) shall not be considered as requirements of the specification.

1.4 The values stated in inch-pound units are to be regarded as standard. The values given in parentheses are mathematical conversions to SI units that are provided for information only and are not considered standard.

1.5 The following precautionary caveat pertains only to the test methods portion, Section 8, of this specification: *This standard does not purport to address all of the safety concerns, if any, associated with its use. It is the responsibility of the user of this standard to establish appropriate safety, health, and environmental practices and determine the applicability of regulatory limitations prior to use.*

1.6 *This international standard was developed in accordance with internationally recognized principles on standardization established in the Decision on Principles for the Development of International Standards, Guides and Recommendations issued by the World Trade Organization Technical Barriers to Trade (TBT) Committee.*

### 2. Referenced Documents

#### 2.1 ASTM Standards:<sup>2</sup>

[D618 Practice for Conditioning Plastics for Testing](#)

[D1600 Terminology for Abbreviated Terms Relating to Plastics](#)

[D1784 Classification System and Basis for Specification for Rigid Poly\(Vinyl Chloride\) \(PVC\) Compounds and Chlorinated Poly\(Vinyl Chloride\) \(CPVC\) Compounds](#)

[D2122 Test Method for Determining Dimensions of Thermoplastic Pipe and Fittings](#)

<sup>1</sup> This specification is under the jurisdiction of ASTM Committee [F17](#) on Plastic Piping Systems and is the direct responsibility of Subcommittee [F17.62](#) on Sewer. Current edition approved Nov. 1, 2016/Nov. 1, 2021. Published December 2016/January 2022. Originally approved in 1972. Last previous edition approved in 2014/2016 as ~~D3034—15~~D3034 – 16.<sup>1</sup>; DOI: ~~10.1520/D3034-16~~10.1520/D3034-21.

<sup>2</sup> For referenced ASTM standards, visit the ASTM website, [www.astm.org](http://www.astm.org), or contact ASTM Customer Service at [service@astm.org](mailto:service@astm.org). For *Annual Book of ASTM Standards* volume information, refer to the standard's Document Summary page on the ASTM website.

\*A Summary of Changes section appears at the end of this standard

**D2152** Test Method for Adequacy of Fusion of Extruded Poly(Vinyl Chloride) (PVC) Pipe and Molded Fittings by Acetone Immersion

**D2321** Practice for Underground Installation of Thermoplastic Pipe for Sewers and Other Gravity-Flow Applications

**D2412** Test Method for Determination of External Loading Characteristics of Plastic Pipe by Parallel-Plate Loading

**D2444** Practice for Determination of the Impact Resistance of Thermoplastic Pipe and Fittings by Means of a Tup (Falling Weight)

**D2564** Specification for Solvent Cements for Poly(Vinyl Chloride) (PVC) Plastic Piping Systems

**D2749** Symbols for Dimensions of Plastic Pipe Fittings

**D2855** Practice for the Two-Step (Primer and Solvent Cement) Method of Joining Poly (Vinyl Chloride) (PVC) or Chlorinated Poly (Vinyl Chloride) (CPVC) Pipe and Piping Components with Tapered Sockets

**D3212** Specification for Joints for Drain and Sewer Plastic Pipes Using Flexible Elastomeric Seals

**F412** Terminology Relating to Plastic Piping Systems

**F477** Specification for Elastomeric Seals (Gaskets) for Joining Plastic Pipe

**F1336** Specification for Poly(Vinyl Chloride) (PVC) Gasketed Sewer Fittings

2.2 *Federal Standard*:<sup>3</sup>

Fed. Std. No. 123 Marking for Shipment (Civil Agencies)

2.3 *Military Standard*:<sup>3</sup>

MIL-STD-129 Marking for Shipment and Storage

### 3. Terminology

3.1 *Definitions*—Definitions are in accordance with Terminology **F412**, and abbreviations are in accordance with Terminology **D1600**, unless otherwise specified. The abbreviation of poly(vinyl chloride) plastics is PVC.

3.1.1 The term PSM is not an abbreviation but rather an arbitrary designation for a product having certain dimensions.

### 4. Significance and Use

4.1 The requirements of this specification are intended to provide pipe and fittings suitable for non-pressure drainage of sewage and surface water.

NOTE 1—Industrial waste disposal lines should be installed only with the specific approval of the cognizant code authority since chemicals not commonly found in drains and sewers and temperatures in excess of  $60^{\circ}\text{C}$  ( $140^{\circ}\text{F}$ )  $60^{\circ}\text{C}$  ( $140^{\circ}\text{F}$ ) may be encountered.

### 5. Basic Materials

5.1 Pipe shall be made of PVC plastic having a cell classification of 12454 or 12364 as defined in Specification **D1784**.

5.2 Fittings shall be made of PVC plastic having a cell classification of 12454 or 13343 as defined in Specification **D1784**.

5.3 *Pipe and Fitting*—Compounds that have different cell classifications, because one or more properties are superior to those of the specified compounds, are also acceptable.

5.4 *Rework Material*—The manufacturer shall use only his own clean pipe or fitting rework ~~material~~; material, which meets cell classification requirements defined in 5.1 (pipe rework material) or 5.2 (fitting rework material); the pipe and fittings produced shall meet all the requirements of this specification.

5.5 *Gaskets*—Rubber gaskets shall comply with Specification **F477**

### 6. Joining Systems

6.1 *Solvent Cement Joints for Pipe and Fittings*—In the solvent cement joint, the pipe spigot wedges into the tapered socket and the surfaces fuse together. The tapered socket may be a portion of a molded fitting or it may be a belled end of the pipe section. Formed bells shall be concentric with the pipe axis.

<sup>3</sup> Available from DLA Document Services Building 4/D 700 Robbins Avenue Philadelphia, PA 19111-5094 <http://quicksearch.dla.mil/>

6.1.1 The assembly of joints shall be in accordance with Practice **D2855**.

6.1.2 *Joint Tightness*—Joints made with pipe and fittings or with belled-end pipe shall show no signs of leakage when tested in accordance with **8.9**.

6.2 *Elastomeric Gasket Joints*, providing a water-tight seal.

6.2.1 The assembly of elastomeric gasket joints shall be in accordance with the pipe and fittings manufacturer’s recommendations.

## 7. Requirements

7.1 *Workmanship*—The pipe and fittings shall be homogeneous throughout and free from visible cracks, holes, foreign inclusions, or other injurious defects. The pipe shall be as uniform as commercially practical in color, opacity, density, and other physical properties.

### 7.2 Pipe Requirements:

7.2.1 *Diameter*—The average outside diameter of the pipe shall meet the requirements given in **Table 1** when measured in accordance with **8.4.1**.

7.2.2 *Wall Thickness*—Pipe wall thicknesses shall meet the requirements of **Table 1** when measured in accordance with Test Method **D2122** and **8.4.2**. In the case of belled pipe and fittings fabricated from pipe sections, the thickness of the wall in the bell shall be considered satisfactory if it was formed from pipe meeting the preceding requirements.

NOTE 2—The wall thickness variability in any cross section of the pipe is normally  $\pm 2\%$  minimum wall thickness  $+12\%$  or less.

7.2.3 *Pipe Flattening*—There shall be no evidence of splitting, cracking, or breaking when pipe is tested in accordance with **8.6**.

7.2.4 *Pipe Impact Strength*—The impact strength of the pipe shall not be less than the values given in **Table 2** when tested in accordance with **8.7**.

NOTE 3—This test is intended only for use as a quality control test, not as a simulated service test.

7.2.5 *Pipe Stiffness*—Pipe stiffness values for the pipe shall comply with **Table 3** when tested in accordance with **8.8**.

7.2.6 *Pipe Extrusion Quality*—The pipe shall not flake or disintegrate when tested in accordance with **8.10**.

### 7.3 Requirements for Solvent Cemented Pipe and Fittings

7.3.1 *Socket Diameter*—The inside diameter of the tapered socket shall comply with the dimensions listed in **Table 4** when determined in accordance with **8.5.1**.

7.3.2 *Socket Depth*—The socket depth shall not be less than that shown in **Table 4** when measured in accordance with **8.5.2**.

**TABLE 1 Pipe Dimensions**

Nominal Size	Outside Diameter		Minimum Wall Thickness			
	Average	Tolerance on Average	SDR 41	DR 35	SDR 26	DR 23.5
3	3.250	±0.008	...	0.093	0.125	0.138
4	4.215	±0.009	...	0.120	0.162	0.178
6	6.275	±0.011	0.153	0.180	0.241	0.265
8	8.400	±0.012	0.205	0.240	0.323	...
10	10.500	±0.015	0.256	0.300	0.404	...
12	12.500	±0.018	0.305	0.360	0.481	...
15	15.300	±0.023	0.375	0.437	0.588	...

**TABLE 2 Minimum Pipe Impact Strength at 23°C (73°F) 23 °C (73 °F)**

Pipe Size, in-Size	Impact Strength, J (ft-lbf)
3	135 (100)
4	203 (150)
6	284 (210)
8	284 (210)
10	299 (220)
12	299 (220)
15	299 (220)

**TABLE 3 Minimum Pipe Stiffness at 5 % Deflection**

Pipe Size, in-Size	Pipe Stiffness, kPa (psi)			
	SDR 41	DR 35	SDR 26	DR 23.5
3 and 4	...	320 (46)	790 (115)	1055 (153)
6 to 15	190 (28)	320 (46)	790 (115)	1055 (153)

**TABLE 4 Solvent Cement Socket Dimensions**

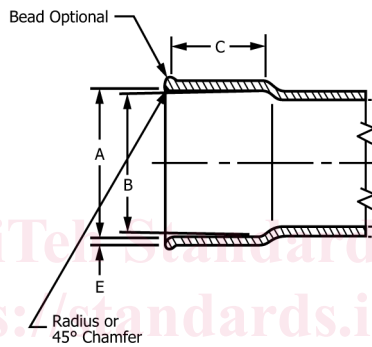

Nominal Size, in.	A	B	C
3	3.271 ± 0.008	3.245 ± 0.008	1.500
4	4.235 ± 0.009	4.210 ± 0.009	1.750
6	6.305 ± 0.011	6.270 ± 0.011	3.000
8	8.424 ± 0.012	8.388 ± 0.012	4.000
10	10.530 ± 0.015	10.485 ± 0.015	5.000
12	12.536 ± 0.018	12.482 ± 0.018	6.000
15	15.346 ± 0.023	15.277 ± 0.023	7.500

7.3.3 Wall Thickness of Molded Fittings:

7.3.3.1 The wall thicknesses of the waterway and socket or bell of molded fittings shall be no less than the respective minimum thicknesses listed for the equivalent pipe in Table 1. For reducing fittings or those with smaller inlets, the minimum wall thickness of each inlet shall be no less than the minimum wall thickness for that size pipe. The thickness shall be determined in accordance with Test Method D2122 and 8.5.3.

7.3.3.2 The wall thickness is a minimum value except that a ±10% variation resulting from core shift is allowable. In such a case, the average of two opposite wall thicknesses shall equal or exceed the value shown in Table 1.

7.3.4 Spigot Length—The minimum distance from the spigot end to the area where the spigot diameter changes due to a socket, branch, or change in angle shall comply with the “C” the “C” dimension of Table 4.

7.4 Fabricated Fittings—Any fitting made from pipe or from a combination of pipe and molded parts shall be considered a fabricated fitting. The actual construction will vary from manufacturer to manufacturer and the following provisions shall apply.

7.4.1 Over-Wrapped Fittings—Fabricated fittings that have an over-wrap of fiberglass reinforced thermosetting resin or other similar materials shall meet all of the requirements in 7.4.2 and 8.11.

NOTE 4—Refer to Appendix X3 for geometric configurations of some of the fittings being produced. Consult the individual manufacturer for laying lengths.

7.4.2 Fabricated Fittings General Requirements:

- 7.4.2.1 Pipe used in fabricated fittings shall meet all quality and dimensional requirements listed in the standard for that pipe.
- 7.4.2.2 Pipe used in fabricated fittings shall have a wall thickness equal to or greater than the wall thickness of the pipes to which the fitting (or that part of the fitting) will be joined.
- 7.4.2.3 No part of the spur or branch shall protrude into the waterway of the fitting more than 0.070 in.
- 7.4.2.4 All edges and joints exposed to sewage shall be rounded and free from any rough parts that could catch solids.
- 7.4.2.5 No fabricated fitting shall have an inside diameter dimension smaller than the value shown in Table 5 for that pipe size and DR for which it is designed.
- 7.4.2.6 All welds and solvent cement joints shall be free of visible defects and shall have full surface-to-surface contact when visually inspected. The full surface-to-surface contact of socket and spigot does not apply in the areas where a taper, chamfer, or radius exists at the socket entrance.

7.5 Solvent Cement—The cement shall meet the requirements of Specification D2564.

7.6 Requirements for Pipe and Fittings with Elastomeric Gasket Joints:

- 7.6.1 Pipe Requirements—In addition to the requirements of 7.2, the assembled joint shall display no leakage when tested in accordance with the requirements of Specification D3212.
- 7.6.1.1 Bells—The dimensions shall be in accordance with the manufacturer’s standard design dimensions and tolerances.
- 7.6.2 Fitting Requirements—With the exception of spigot lengths, molded and fabricated fittings with elastomeric gasket joints shall comply with the requirements of Specification F1336.
- 7.6.2.1 Spigot Length—The minimum distance from the spigot end to the area where the spigot diameter changes due to a socket, branch, or change in angle shall comply with the “C” dimension of Table 4.

8. Test Methods

8.1 Conditioning:

TABLE 5 Minimum Inside Diameter of Fabricated Fittings

Nominal Size, in.	SDR-41	SDR-35	SDR-26	SDR-23.5	SDR 23.5
	Nominal Size	SDR-41	SDR-35	SDR-26	
Minimum Inside Diameter		Minimum Inside Diameter	Minimum Inside Diameter	Minimum Inside Diameter	
		in.			
6	5.800	5.742	5.612	5.562	
8	7.740	7.665	7.488	...	
10	9.657	9.563	9.342	...	
12	11.478	11.361	11.102	...	
15	14.029	13.898	13.575	...	
		(mm)			
6	(147.32)	(145.85)	(142.54)	(141.27)	
8	(196.60)	(194.69)	(190.20)	...	
10	(245.29)	(242.90)	(237.29)	...	
12	(291.54)	(288.57)	(281.99)	...	
15	(356.34)	(353.01)	(344.80)	...	

8.1.1 *Referee Testing*—Unless otherwise specified, for referee tests, condition the test specimens at  $23 \pm 2^\circ\text{C}$  ( $73.42^\circ\text{C}$  ( $73^\circ\text{F} \pm 3.6^\circ\text{F}$ )) and  $50 \pm 5\%$  ( $4^\circ\text{F}$ ) and  $50\% \pm 10\%$  relative humidity for not less than 40 h prior to test in accordance with Procedure A of Practice **D618**, for those tests where conditioning is required.

8.1.2 *Quality Control Testing*—For quality control tests, condition specimens for not less than 2 h in air or 1 h in water at  $23 \pm 2^\circ\text{C}$  ( $73.42^\circ\text{C}$  ( $73^\circ\text{F} \pm 3.6^\circ\text{F}$ )) and  $50 \pm 5\%$  ( $4^\circ\text{F}$ ). Test the specimens at  $23 \pm 2^\circ\text{C}$  ( $73.42^\circ\text{C}$  ( $73^\circ\text{F} \pm 3.6^\circ\text{F}$ )) and  $50 \pm 5\%$  ( $4^\circ\text{F}$ ) without regard to relative humidity.

## 8.2 Test Conditions:

8.2.1 *Referee Testing*—For referee tests, conduct tests in the standard laboratory atmosphere of  $23 \pm 2^\circ\text{C}$  and  $50 \pm 5\%$  ( $23^\circ\text{C} \pm 2^\circ\text{C}$  ( $73^\circ\text{F} \pm 4^\circ\text{F}$ )) and  $50\% \pm 10\%$  relative humidity, unless otherwise specified in the test methods or in this specification.

8.2.2 *Quality Control Testing*—For quality control, test the specimens at  $23 \pm 2^\circ\text{C}$  ( $73.42^\circ\text{C}$  ( $73^\circ\text{F} \pm 3.6^\circ\text{F}$ )) and  $50 \pm 5\%$  ( $4^\circ\text{F}$ ) without regard to relative humidity.

8.3 *Sampling*—The selection of the sample or samples of pipe or fitting shall be as agreed upon between the purchaser and the seller. In case of no prior agreement, any sample selected by the testing laboratory shall be deemed adequate.

## 8.4 Pipe Dimensions:

8.4.1 *Pipe Diameters*—Measure the average outside diameter of the pipe in accordance with the applicable section of Test Method **D2122**. Either a tapered sleeve gage or a vernier circumferential wrap tape accurate to  $\pm 0.02$  mm ( $\pm 0.001$  in.) may be used.

8.4.2 *Wall Thickness*—Measure the wall thickness in accordance with the applicable section of Test Method **D2122**. Make sufficient readings, a minimum of six, to ensure that the minimum thickness has been determined. Use a cylindrical anvil tubing micrometer accurate to  $\pm 0.02$  mm ( $\pm 0.001$  in.).

## 8.5 Fittings Dimensions:

8.5.1 *Socket Diameters*—Measure the inside diameters of the sockets at the entrance and bottom in accordance with the applicable section of Test Method **D2122**. Calculate the average inside diameters at the entrance and the bottom of the socket by taking the mean of the minimum and maximum values.

8.5.2 *Socket Depth*—Measure the fitting socket depth using a steel rule with at least 1-mm ( $1/16$ -in.) graduations in accordance with the applicable section of Test Method **D2122**.

8.5.3 *Wall Thickness*—Measure the wall thickness in accordance with the applicable section of Test Method **D2122**. Make sufficient readings, a minimum of six, to ensure that the minimum thickness has been determined. Use a cylindrical anvil tubing micrometer accurate to  $\pm 0.02$  mm ( $0.001$  in.).

8.6 *Pipe Flattening*—Flatten three specimens of pipe, 150 mm (6 in.) long, between parallel plates in a suitable press until the distance between the plates is 40 % of the outside diameter of the pipe. The rate of loading shall be uniform and such that the compression is completed with 2 to 5 min. Remove the load and examine the specimens for evidence of splitting, cracking, or breaking.

8.7 *Impact Resistance*—Determine the impact resistance of the pipe in accordance with the applicable section of Test Method **D2444**, A 20-lb or 30-lb Tup B and the flat plate Holder B shall be used for sizes 3-6 in. and a 20-lb or 30-lb Tup A and the flat plate Holder B shall be used for sizes 8-15 in. Test six specimens each 150 mm (6 in.) long at the impact levels given in **Table 2**. All shall pass. If one fails, test another six specimens; 11 passes out of 12 tested shall be acceptable.

8.8 *Pipe Stiffness*—Determine the pipe stiffness at 5 % deflection using Test Method **D2412**. Test three specimens each 150 mm (6 in.) long and determine the average pipe stiffness at 5 % deflection. The pipe stiffness shall equal or exceed the minimum value listed in **Table 3**.

NOTE 5—The 5 % deflection criterion, which was arbitrarily selected for testing convenience, should not be considered as a limitation with respect to in-use deflection. The engineer is responsible for establishing the acceptable deflection limit (Appendix X1).

8.9 *Joint Tightness*—Join two pieces of pipe by means of a fitting or socket in accordance with Practice D2855 and using solvent cement as described in 7.5. Allow the joined unit to stand 24 h at room temperature. Subject the unit to an internal water pressure of 170 kPa (25 psi) at room temperature for 1 h, and examine the pipe, fitting, and joints for leakage.

8.10 *Extrusion Quality*—Tests shall be run in accordance with Test Method D2152. This procedure is used for determining the extrusion quality of extruded PVC plastic pipe as indicated by reaction to immersion in anhydrous acetone. It is applicable only for distinguishing between unfused and properly fused PVC.

8.11 *Fabrication Joint Test Requirements:*

8.11.1 These test requirements apply only to tee, wye, and bend fabricated fittings that are manufactured using fabrication methods that join together a combination of pipe sections or pipe sections and molded parts to form a fitting configuration. Other fitting configurations using the same manufacturing procedures as those tested successfully shall be suitable for sale and use. Fittings fabricated from a single-piece of pipe to form Bends and Sweeps shall not be subject to this requirement. **Warning**—A brittle fitting may violently fragment during testing. To preclude serious injury or death, suitable and appropriate safety procedures shall be used during any test procedure.

8.11.2 Fabricated fittings shall be supported along the fitting centerline on a flat wooden block or blocks as shown in Figs. 1 and 2.

(1) The width of the wooden blocks shall be not less than 66 % of the nominal fitting body size being tested for fabricated fittings up to 18 in. and 12 in. (305 mm) in width for nominal body sizes over 18 in.

(2) The thickness of the wooden blocks shall be neither less than, nor more than 1 in. (25.4 mm) greater than the difference between the largest outside diameter on the bell and the outside of the body being tested.

(3) The wooden blocks shall stop  $1 \pm \frac{1}{8}$  in. ( $25.4 \pm 3.2$  mm) from the fitting bells and when required for bends shall be mitered as indicated in Fig. 2 so that the wooden blocks cover the entire centerline of the fabricated fitting being tested.

8.11.2.1 The wooden blocks shall be made from an available softwood and the type of wood shall be noted on the test report.

8.11.2.2 When comparative testing is being performed between labs the same type of softwood blocks shall be used.

8.11.3 Deflect the fabricated fitting by applying the load, calculated from the values given in Table 6 to the body of the fitting as shown in Fig. 1. The body length for this calculation shall not include any part of a taper or transitional area between the fitting body and the bell as shown in Fig. 2. Apply the calculated load at a constant rate over a 1 to 2 min. period and then maintain the load for 5 (five) minutes. The calculated load required shall be applied to a second wooden block or blocks that are located along the fitting centerline on top of the fitting as shown in Fig. 2.

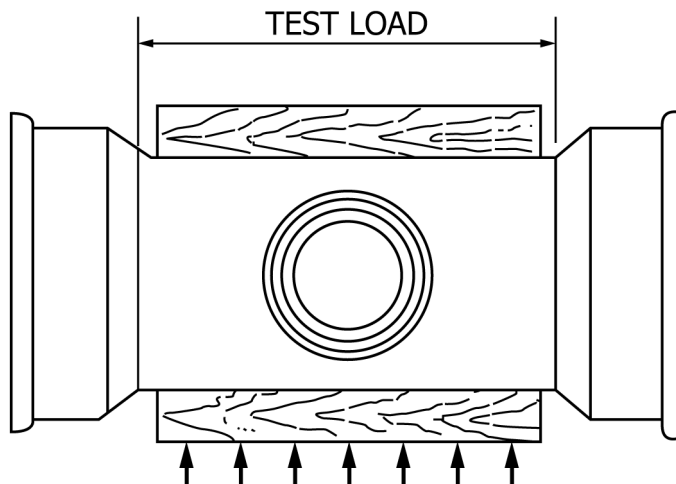

FIG. 1 Deflection Test for Fabricated PVC Fittings