



Designation: ~~E1678–21~~ E1678 – 21a

An American National Standard

Standard Test Method for Measuring Smoke Toxicity for Use in Fire Hazard Analysis¹

This standard is issued under the fixed designation E1678; the number immediately following the designation indicates the year of original adoption or, in the case of revision, the year of last revision. A number in parentheses indicates the year of last reapproval. A superscript epsilon (ϵ) indicates an editorial change since the last revision or reapproval.

INTRODUCTION

The pyrolysis or combustion of every combustible material or product produces smoke that is toxic. It is, therefore, desirable to establish a test method for the development of data characterizing smoke toxicity as an element of fire hazard analyses for both pre-flashover and post-flashover fires. The test method includes quantification of the toxicity of the smoke and ascertain whether the observed toxicity can be attributed to the major common toxicants.

1. Scope*

1.1 This fire-test-response standard covers a means for determining the lethal toxic potency of smoke produced from a material or product ignited while exposed to a radiant heat flux of 50 kW/m² for 15 min.

1.2 This test method is limited to test specimens no larger than 7676 mm by 127 mm (3(3 in. by 5 in.), with a thickness no greater than 51 mm (2 in.). Specimens are intended to be representative of finished materials or products, including composite and combination systems.

1.3 Lethal toxic potency values associated with 30-min exposures are predicted using calculations that use combustion atmosphere analytical data for carbon monoxide, carbon dioxide, oxygen (vitiation) and, if present, hydrogen cyanide, hydrogen chloride, and hydrogen bromide. The predictive equations are therefore limited to those materials and products whose smoke toxicity can be attributed to these toxicants. An animal check determines the extent to which additional toxicants contribute to the lethal toxic potency of the smoke.

1.4 The values stated in SI units are to be regarded as standard. The values given in parentheses after SI units are provided for information only and are not considered standard.

1.5 This standard measures and describes the response of materials, products, or assemblies in response to heat under controlled conditions, but does not by itself incorporate all factors required for fire hazard of fire risk assessment of the materials, products, or assemblies under actual fire conditions.

1.6 *This standard does not purport to address all of the safety concerns, if any, associated with its use. It is the responsibility of the user of this standard to establish appropriate safety, health, and environmental practices and determine the applicability of regulatory limitations (particularly with regard to the care and use of experimental animals) prior to use.* For specific hazards statements, see Section 7 and **Note X1.1**.

¹ This test method is under the jurisdiction of ASTM Committee E05 on Fire Standards and is the direct responsibility of Subcommittee E05.21 on Smoke and Combustion Products.

Current edition approved July 1, 2021/Dec. 1, 2021. Published August 2021/January 2022. Originally approved in 1995. Last previous edition approved in 2015/2021 as E1678 – 15/E1678 – 21. DOI: 10.1520/E1678-21.10.1520/E1678-21A.

*A Summary of Changes section appears at the end of this standard

1.7 This international standard was developed in accordance with internationally recognized principles on standardization established in the Decision on Principles for the Development of International Standards, Guides and Recommendations issued by the World Trade Organization Technical Barriers to Trade (TBT) Committee.

2. Referenced Documents

2.1 ASTM Standards:²

E176 Terminology of Fire Standards

E800 Guide for Measurement of Gases Present or Generated During Fires

2.2 ISO Documents:³

ISO 19701 Methods for Sampling and Analysis of Fire Effluents

ISO 19702 Guidance for Sampling and Analysis of Toxic Gases and Vapours in Fire Effluents Using Fourier Transform Infrared (FTIR) Spectroscopy

2.3 NFPA Standard:⁴

NFPA 269-2017 Standard Test Method for Developing Toxic Potency Data for Use in Fire Hazard Modeling

3. Terminology

3.1 *Definitions*—For definitions of general terms used in this test method, refer to Terminology **E176**.

3.2 *Definitions of Terms Specific to This Standard:*

3.2.1 *carboxyhemoglobin saturation, n*—the percent of blood hemoglobin predominately converted to carboxyhemoglobin from reaction with inhaled carbon monoxide.

3.2.1.1 Discussion—

The chemical reaction between carbon monoxide and hemoglobin in blood is reversible. The effect of carbon monoxide on the exposed person may not be reversible.

3.2.2 *concentration-time curve, n*—a plot of the concentration of a gaseous toxicant as a function of time.

3.2.2.1 Discussion—

The concentration-time curve can also be used to represent the sum total of all combustion products instead of just a single one.

3.2.3 *Ct product, n*—the concentration-time product in (µL/L)-min obtained by integration of the area under a concentration-time curve.

3.2.3.1 Discussion—

Values expressed using this unit are numerically equal to those using the previously cited unit, ppm, a term whose use is discouraged.

3.2.4 *fractional exposure dose (FED), n*—the ratio of the integrated area under the concentration-time curve for a gaseous toxicant or the sum of all combustion products produced in a given test to that integrated C(t) area which has been determined statistically from independent experimental data to produce lethality in 50 % of test animals within a specified exposure and postexposure time.

3.2.4.1 Discussion—

When C is nearly constant over time, the time values in this ratio numerically cancel, and the FED is simply the ratio of the average concentration of a gaseous toxicant to its LC₅₀ value for the same exposure time. When only a single measurement of C is made during a test, the accuracy of this simplification is not known. When not used with reference to a specific toxicant, the term FED represents the summation of FEDs for individual toxicants in a combustion atmosphere.

3.2.5 *LC₅₀, n*—a measure of lethal toxic potency; the concentration of gas or smoke calculated statistically from concentration-response data to produce lethality in 50 % of test animals within a specified exposure and postexposure time, expressed in µL/L.

3.2.5.1 Discussion—

Values expressed using this unit are numerically equal to those using the previously cited unit, ppm, a term whose use is discouraged.

3.2.6 *mass loss concentration, n*—the mass loss of a test specimen per unit exposure chamber volume in g·m⁻³.

² For referenced ASTM standards, visit the ASTM website, www.astm.org, or contact ASTM Customer Service at service@astm.org. For *Annual Book of ASTM Standards* volume information, refer to the standard's Document Summary page on the ASTM website.

³ Available from American National Standards Institute (ANSI), 25 W. 43rd St., 4th Floor, New York, NY 10036, <http://www.ansi.org>.

⁴ Available from National Fire Protection Association (NFPA), 1 Batterymarch Park, Quincy, MA 02269, <http://www.nfpa.org>.

3.2.7 *post-flashover*, *n* and *adj*—referring to the state of a fire after flashover.

4. Summary of Test Method

4.1 In this test method, a test specimen is subjected to ignition while it is exposed for 15 min to a radiant heat flux of 50 kW/m². (See X1.2.2.) The smoke produced is collected for 30 min within a 200-L chamber communicating with the combustion assembly through a connecting chimney. Concentrations of the major gaseous toxicants are monitored over the 30-min period, with Ct products for each being determined from integration of the areas under the respective concentration-time plots. The Ct product data, along with the mass loss of the test specimen during the test, are then used in calculations to predict the 30-min LC₅₀ of the test specimen.

4.2 The predicted LC₅₀ is then confirmed in comparable tests by exposing six rats, restrained for head-only exposure, for 30 min to the smoke produced from that mass of the test specimen whose mass loss concentration during the 30-min period is approximately ($\pm 10\%$) equivalent to 70 % and to 130 % of its estimated LC₅₀. If no more than one rat dies during the 30-min exposure, or within 14-days ~~postexposure~~ post-exposure to the mass loss concentration corresponding to 70 % of the LC₅₀, and at least five rats die during the 30-min exposure, or within 14-days ~~postexposure~~ post-exposure, to the mass loss concentration corresponding to 130 % of the LC₅₀, the predicted LC₅₀ is considered to be confirmed. Confirmation ensures that the monitored toxicants account for the observed toxic effects.

4.3 An animal test result that does not confirm the prediction indicates the presence of one or more additional toxicants or toxicological antagonists, and the degree of disagreement indicates the importance of the unmeasured factors.

4.4 For calculation of hazard from pre-flashover, flaming fires, the toxicant gas yields and LC₅₀ values are to be used as experimentally determined. For calculation of hazard from post-flashover fires, the yields of carbon monoxide are augmented to reflect the higher yields produced in such fires. The experimental LC₅₀ values are then adjusted using a specified calculation to produce LC₅₀ (post-flashover) values.

5. Significance and Use

5.1 This test method has been designed to provide data for the mathematical modeling of fire hazard as a means for the evaluation of materials and products and to assist in their research and development.

5.1.1 Test Method E1678 is functionally equivalent to NFPA 269-2017.

5.2 This test method is used to predict, and subsequently confirm, the lethal toxic potency of smoke produced upon the exposure of a material or product to specific fire test conditions. Confirmation determines whether certain major gaseous toxicants account for the observed toxic effects and lethal toxic potency. If a predicted lethal toxic potency value is not confirmed adequately, indicating a potential for unusual or unexplained toxicity, the lethal toxic potency will need to be investigated using other methodology, such as conducting an experimental determination of the LC₅₀ using the apparatus described. (See X1.3.1 and X1.3.2.)

5.3 This test method produces lethal toxic potency values that are appropriate for use in the modeling of both pre-flashover and post-flashover fires. Most fire deaths due to smoke inhalation in the U.S. occur in areas other than the room of fire origin and are caused by fires that have proceeded beyond the room of fire origin. It is assumed that these are flashover fires. Therefore, the principal emphasis is placed on evaluating toxic hazard under these conditions. In post-flashover fires, large concentrations of carbon monoxide results from reduced air supply to the fire plume and other room-scale factors. Bench-scale tests do not have the capacity to simulate these phenomena. The lethal toxic potency values determined in this test method are obtained from fuel/air ratios more representative of pre-flashover, rather than post-flashover conditions. In cases where a pre-flashover fire representation is desired in fire hazard modeling, these LC₅₀ values are appropriate. Lethal toxic potency and carbon monoxide yield values determined in this test method require adjustment for use in modeling of the hazard from post-flashover conditions. (See X1.4.1.)

5.4 The lethal toxic potency values determined in this test method have a level of uncertainty in their accuracy when used to predict real-scale toxic potencies. (See X1.4.2.)

5.4.1 The accuracy of the bench-scale data for pre-flashover fires has not been established experimentally. The combustion conditions in the apparatus are quite similar to real pre-flashover fires, although the mass burning rate may be higher at the 50 kW/m² irradiance of the test method.

5.4.2 Comparison of the toxicant yields and LC₅₀ (post-flashover) values obtained using this method have been shown in limited tests (1) to reproduce the LC₅₀ values from real-scale, post-flashover fires to within an accuracy of approximately a factor of three. Therefore, LC₅₀ (post-flashover) values differing by less than a factor of three are indistinguishable from each other. (See X1.4.2.)

5.5 This test method does not attempt to address the toxicological significance of changes in particulate and aerosol size, smoke transport, distribution, or deposition or changes in the concentration of any smoke constituent as a function of time as may occur in a real fire.

5.6 The propensity for smoke from any material to have the same effects on humans in fire situations can be inferred only to the extent that the rat is correlated with humans as a biological system.

5.7 This test method does not assess incapacitation. Incapacitation must be inferred from lethal toxic potency values.

5.8 The effects of sensory irritation are not addressed by this test method.

6. Apparatus

6.1 *Animal Exposure Chamber*—Shown in Figs. 1 and 2, a transparent polycarbonate or polymethylmethacrylate chamber with a nominal volume of 0.2 m³ (200 L). (See X1.2.5.) Its inside dimensions are 1220 mm by 370 mm by 450 mm (48 in. by 14½ in. by 17¾ in.). The six animal ports, intended for head-only exposure, are located in a horizontal row, approximately half way from the bottom to the top of the chamber, in the front wall. A plastic bag with an approximate volume of 0.05 m³ (50 L or approximately 13 gal) is attached to the port at the end of the chamber during a test to provide for gas expansion. The exposure box is equipped with a gas sampling port at the animal nose level in the geometric center of the exposure chamber and with a port for returning gases in the end wall closest to the gas analyzers. A thermocouple shall be provided to monitor the temperature at the level of the animal ports. There are two doors in the exposure chamber, in the front wall near the connection to the combustion cell and in the end wall nearest the animal ports. The purpose of the doors is to allow for cleaning and maintenance of the chamber, chimney, and smoke shutter and to provide fresh air during calibration of the heat lamps and immediately prior to testing.

6.2 *Smoke Shutter*, made of stainless steel plate and situated inside the animal exposure chamber. It is positioned so that it will close over the chimney opening. It is hinged and provided with a positive locking mechanism. The purpose of the shutter is to seal the combustion chamber and chimney from the exposure chamber at the end of irradiation. A wire attached to the shutter and a simple push rod are provided for gentle closing of the shutter. A wire attached to a clamp locks the shutter in place. To produce

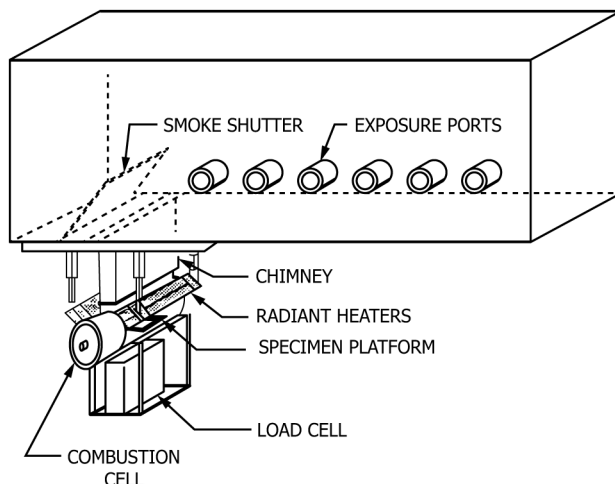

FIG. 1 Overall View of the Apparatus

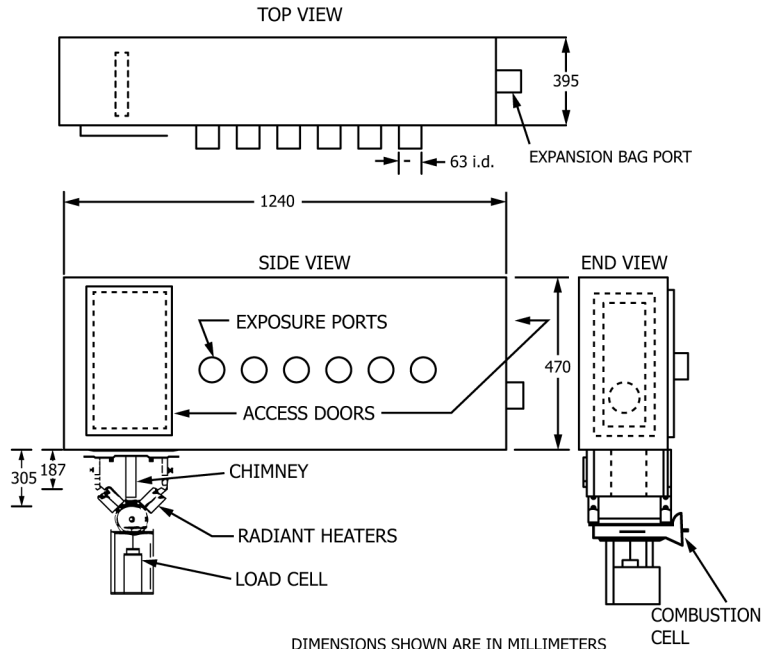

FIG. 2 Schematic Drawing of the Apparatus

a gas-tight seal, the underside of the shutter is covered with a 12-mm 12 mm (0.5-in.) thick blanket of low-density ceramic fiber insulation (approximately 65 kg/m^3), which is further covered with stainless steel foil.

6.3 *Chimney* (Fig. 3)—A stainless steel assembly approximately 303 mm by 300 mm ($1\frac{1}{4}\text{ in.}$ by $11\frac{3}{4}\text{ in.}$), inside dimensions, and 300 mm ($11\frac{3}{4}\text{ in.}$) wide. It connects the combustion cell to the animal exposure chamber. The chimney is divided into three

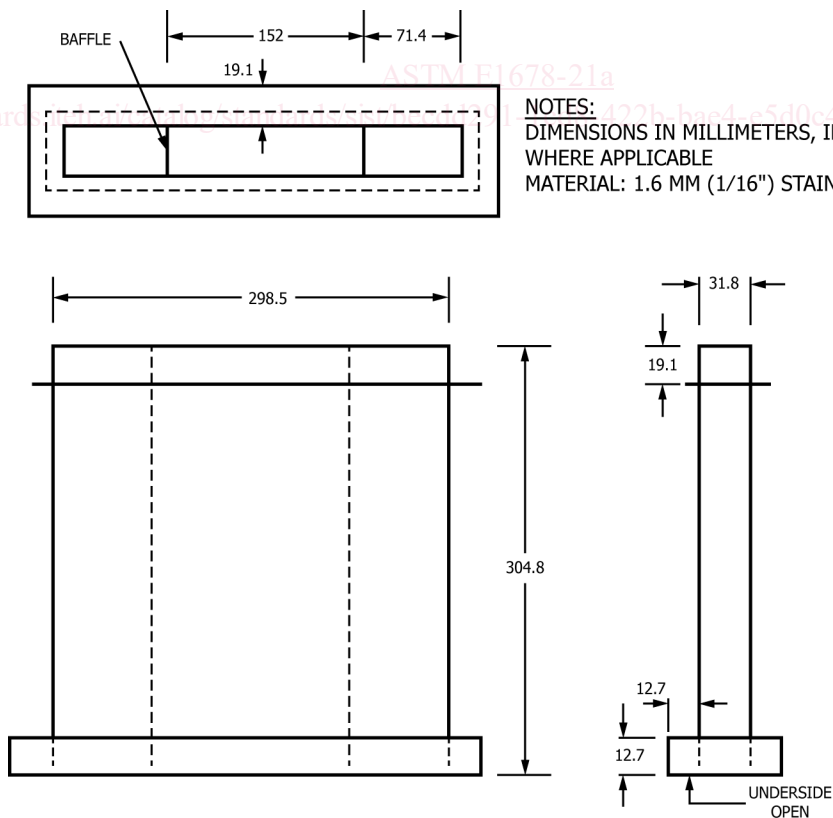

FIG. 3 Stainless Steel Chimney

channels by stainless steel dividers. The center channel is approximately 150 mm (6 in.) wide. The purpose of the dividers is to induce smoke to travel up through the center portion of the chimney, while air from the animal exposure chamber is drawn down through the outside channels to provide air to the combustion cell. The chimney is connected to the underside of the animal exposure chamber by clamps, permitting its removal for cleaning. It is sealed to the animal chamber by low-density ceramic fiber insulation (approximately 65 kg/m³). The other end of the chimney is sealed to the combustion cell by an H-shaped trough with a small quantity of the same fiber insulation in the trough.

6.4 *Combustion Cell*—Shown in Figs. 4-6, a horizontal quartz tube with a 127-mm (5-in.) inside diameter and approximately 320 mm (12½ in.) long. It is sealed at one end and has a large standard taper outer joint at the other end. A sealed inner joint serves as a removable plug for the open end (Fig. 6). The combustion cell has a rectangular opening on the top parallel to the axis of the cylinder with a “collar” that allows it to fit securely into the chimney. The bottom of the cell has a hole for the rod connecting the specimen support platform and load cell. The sealed end of the combustion cell is fitted with a glass collar to accommodate the electric sparker.

6.4.1 The combustion cell is supported by a metal frame that also holds the load cell (Figs. 4 and 5). This entire frame is supported by a laboratory jack that holds the combustion cell tightly to the chimney during experimentation and allows the cell to be lowered for removal and cleaning. The load cell is always at a fixed distance from the combustion cell.

6.5 *Radiant Heaters:*

6.5.1 The active element of the heater consists of four quartz infrared lamps (with tungsten filaments), rated at 2000 W at 240 V. The lamps (two on each side) are encased in water-cooled holders with parabolic reflectors. These holders (Fig. 4) are attached to adjustable metal frames, which allow the lamps to be moved vertically and laterally and rotated in such a way as to provide a uniform flux field across the sample surface. Cooling water must be circulated through the lamps’ respective holders to keep them from overheating. The lamps must not be operated without the cooling water.

(<https://standards.iteh.ai>)

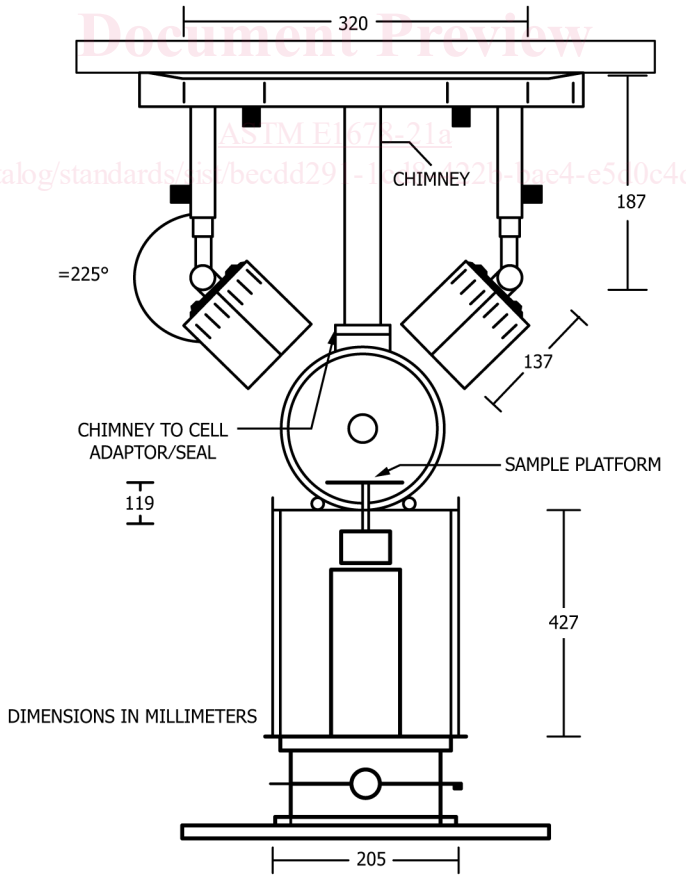

FIG. 4 Front View of the Combustion Zone

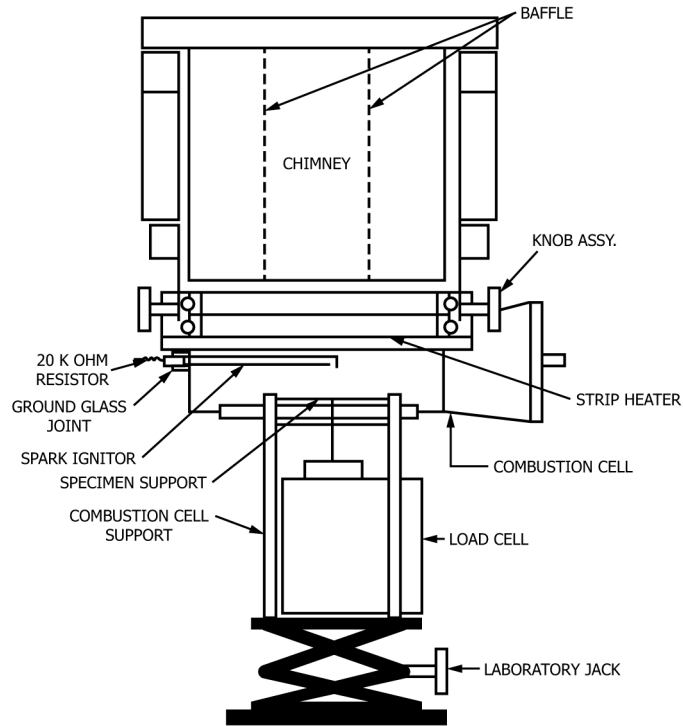

FIG. 5 Side View of the Combustion Zone

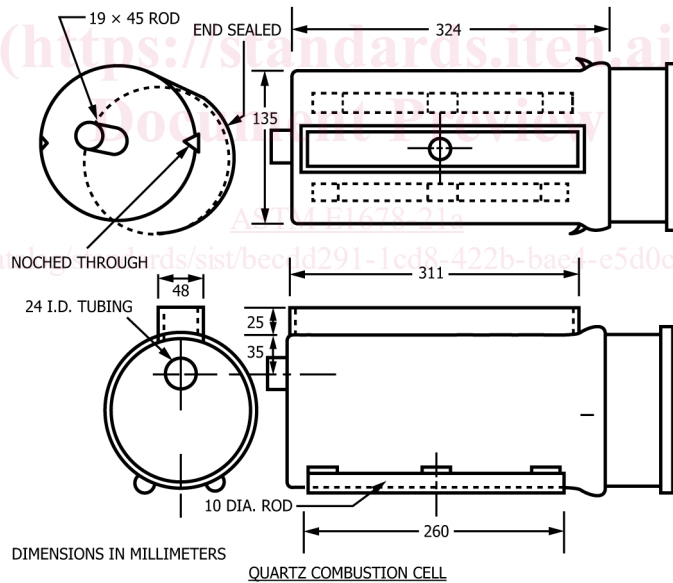

FIG. 6 Combustion Cell

6.5.2 The irradiance of the lamps must be held at a preset level. One method entails a temperature controller and two thermocouples (Type K) that are placed between the lamps and the combustion cell and wired in parallel.

6.5.3 The irradiance from the lamps shall be uniform within the central area of the specimen holder to within $\pm 10\%$. Fig. 7 shows the calibration holder to be used when determining the uniformity of the radiant field from the lamps. The lampholders must be repositioned, as necessary, if the field is found not to be adequately uniform.

6.6 *Temperature Controller* (Optional)—When a temperature controller is used for maintaining the required radiant flux, the quartz lamp output is controlled by a thermocouple signal to the temperature controller. The outputs from the two Type K thermocouples

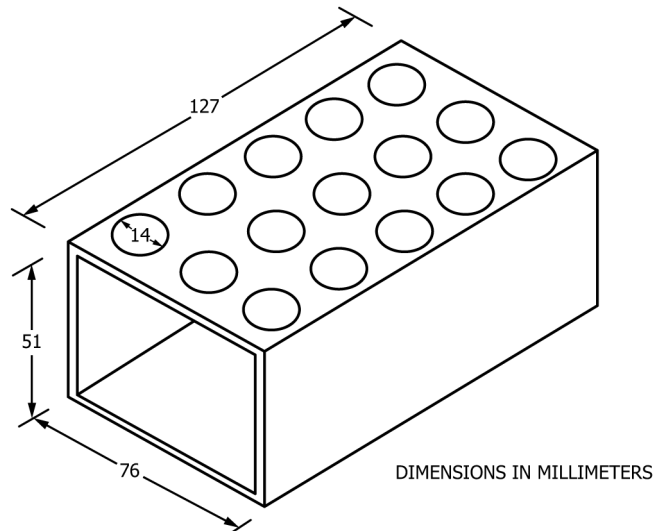

FIG. 7 Calibration Jig

are averaged by means of a parallel-wired connection, and this averaged value is used as the input to the controller. The temperature controller must be a three-term type and must provide an output signal suitable for driving the power controller. The temperature controller must also incorporate a means for setting the maximum output to prevent the power controller from being driven wide-open, if needed. The power controller is selected to be compatible with the radiant heat lamps used.

6.7 Heat Flux Meter:

6.7.1 The total heat flux meter shall be of the Schmidt-Boelter (thermopile) type or equivalent, with a design range of at least 75 kW/m². The target receiving radiation shall be flat, circular, approximately 12.5 mm in diameter, and coated with durable matt-black finish. The target shall be water cooled. The flux meter shall have an accuracy of within $\pm 3\%$ and a repeatability within 0.5 %.

6.7.2 The calibration of the heat flux meter must be checked periodically. This is accomplished most readily by having two flux meters, one used for routine testing and another used only for calibration purposes.

6.7.3 The flux meter shall be used to calibrate the radiant heater temperature controller. It shall be positioned in a rigid support device to ensure repeatable readings. The surface of the heat flux meter must be located at a position equivalent to the center of the specimen face. Fig. 7 indicates a calibration bracket suitable for this purpose.

6.8 *Ignitor*—A spark ignitor is constructed of two ~~3.2 mm~~ 3.2 mm (0.125-in.) stainless steel rods. One of these two rods is bent at 90°, flattened on the end, and positioned to have the appearance of the tip of an automotive spark plug. The gap between the two rods shall be 22 mm ± 0.5 mm. The two rods are connected to the high-voltage spark system, which uses a ~~10 kV~~ 10 kV transformer (Fig. 8). ~~A 20 000- Ω , 5-W~~ A 20 000 Ω , 5 W resistor is connected in series with one of the electrodes to reduce the propagation of radio frequency interference into the instrumentation. The spark gap is positioned approximately 25 mm (1 in.) above the center of the top surface of the specimen, inside the combustion cell. In one operation method, the rods comprising the spark igniter pass through a 29/42 male ground glass stopper, forming a gas-tight seal with a mating joint in place of the collar on the combustion cell (Fig. 6). Otherwise, the electrical leads shall be sealed in the glass collar in a gas-tight manner.

6.9 *Specimen Holder*—A stainless steel assembly approximately 76 mm by 127 mm (3 in. by 5 in.), inside dimensions, and 50 mm (2 in.) deep (Fig. 9). The specimen is backed by a layer of ceramic fiber blanket of nominal 65-kg-m⁻³ density. The specimen holder is positioned for testing on the specimen platform, inside the combustion cell.

6.10 *Load Cell*—The general arrangement of the load cell and specimen holder is illustrated in Fig. 5. The load cell is installed under the combustion cell and is insulated against heating from the lamps. The specimen and holder are located on a support plate and a rigid rod. The load cell shall have an accuracy of 0.01 g, and it shall have a measuring range of at least 100 g.

6.11 Gas Sampling:

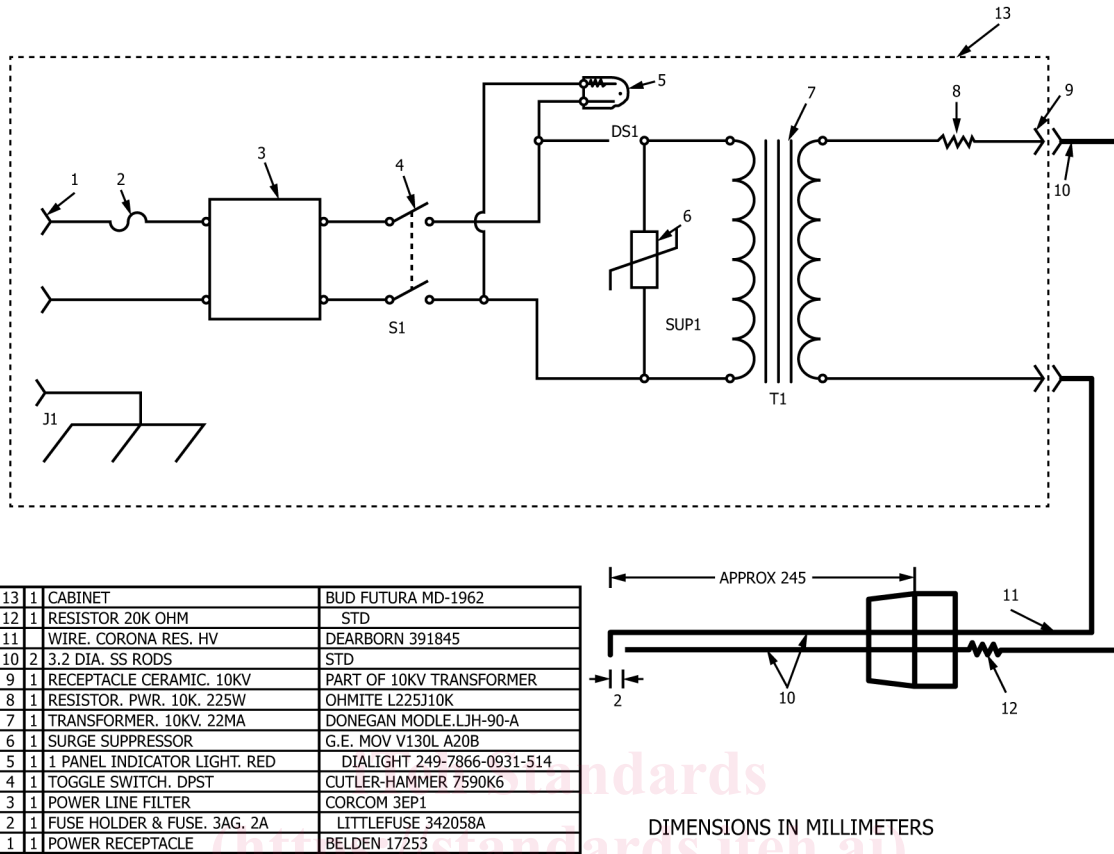

FIG. 8 Spark Igniter System

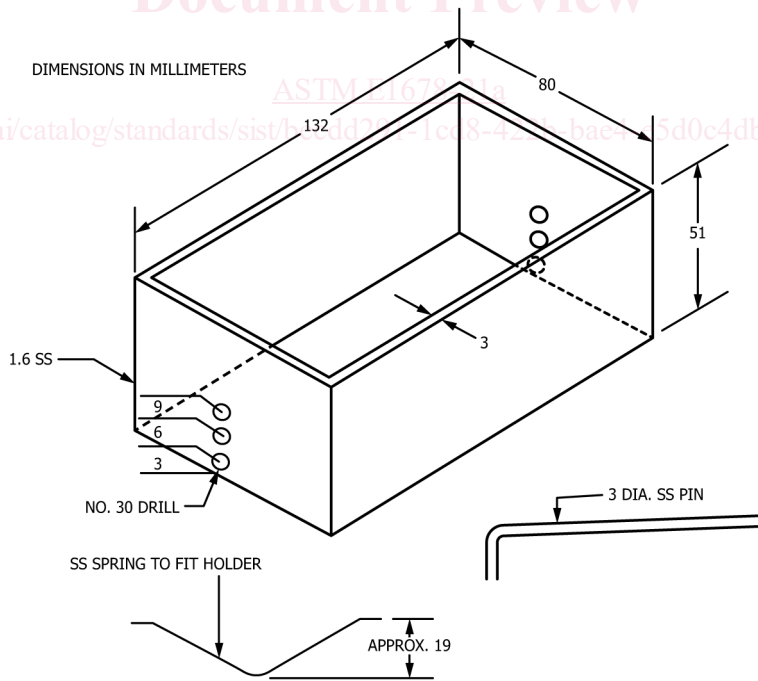

FIG. 9 Specimen Holder

6.11.1 The gas sampling system shall be designed in accordance with the requirements specified in Guide E800. Gases that are removed for chemical analysis and that can be recirculated to the animal exposure chamber are returned since this is a closed

system. A suitable gas sampling arrangement includes a pump, glass wool filter at the sampling port, cold trap to remove soot and moisture, and pressure relief valve that returns all flow not required by the CO, CO₂, and O₂ gas analyzers. The flow to these analyzers is also returned to the animal exposure chamber through separate return lines. The return lines shall be closed during calibration of the instruments to prevent the accumulation of calibration gases in the animal exposure chamber.

6.11.2 *Gas Analyzers:*

6.11.2.1 The oxygen analyzer shall have a range from 00 % to 21 %.

6.11.2.2 The carbon dioxide analyzer shall have a range from at least 00 % to 10 %.

6.11.2.3 The carbon monoxide analyzer shall have a range from at least 00 μL/L to 10 000 μL/L.

NOTE 1—Most carbon monoxide analyzers display CO concentrations in ppm. Values expressed in ppm are numerically equal to those expressed in μL/L.

6.11.2.4 Additional gas analysis for HCN, HCl, or HBr shall be performed when the nature of the test specimen indicates the possibility of these gases being present in the combustion products. Analysis for these gases shall follow the instructions given in Guide E800. For any gases with which analysis methods are used that involve chemical reaction, such products are not returned to the animal exposure chamber but, rather, disposed of in an environmentally correct manner.

6.12 *Data Collection*—The data collection system must have the capability of recording the output from the gas analyzers, thermocouple(s) in the chamber, and load cell and shall have an accuracy corresponding to 0.01 % of full-scale instrument output.

6.13 *Animal Restraint*—Animal restrainers made of aluminum and designed to permit head-only exposures shall be used. A detailed illustration of an animal restrainer meeting this requirement is shown in Fig. 10.

7. Hazards

7.1 This test method involves bright lights, high temperatures, and combustion processes. Hazards may, therefore, exist for eye injuries, burns, ignition of extraneous objects, and inhalation of combustion products. To prevent the accidental leakage of toxic combustion products into the surrounding atmosphere, the entire exposure system should be placed into a chemical hood or under a canopy hood. If under a canopy hood, an accessory exhaust trunk for any combination gases escaping through the load cell hole on the bottom of the combustion cell is required. An exhaust line to evacuate the exposure box at the end of a test is recommended. The operator must use safety tongs for removal of the specimen holder. While hot, the combustion cell must be touched only with protective gloves. Due to the intense light from the infrared lamps used, dark safety glasses must be worn by the operator, or a darkened polymethylmethacrylate or polycarbonate shield must be placed in front of the combustion cell.

7.2 The venting system for the exposure chamber must be checked for proper operation before testing and must discharge into an exhaust system with adequate capacity.

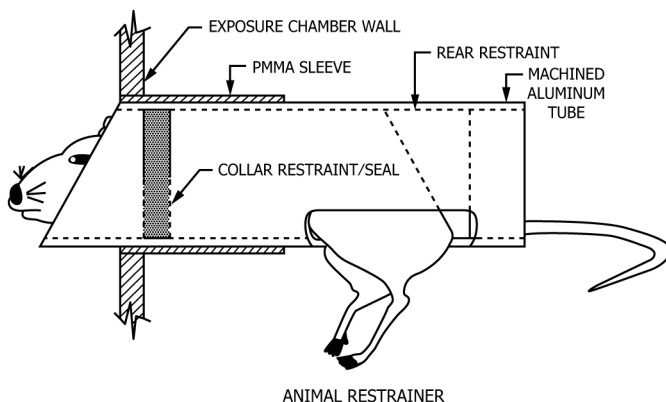

ANIMAL RESTRAINER
FIG. 10 Animal Restraint

8. Test Specimens

8.1 Test specimens shall be cut to an appropriate area (see Section 12), no larger than ~~76~~76 mm by 127 mm (~~3~~3 in. by 5 in.) and no thicker than 50 mm (2 in.) (see X1.2.3), representing the end-use product. Raw materials (for example, paints, adhesives, wall coverings, etc.) shall be tested on the substrate to which they are normally applied. Wrap the specimens for testing on all sides except for the top face with either aluminum or stainless steel foil.

8.2 The test specimens shall be conditioned at an ambient temperature of ~~23~~23 °C ± 3 °C (~~73~~73 °F ± 5 °F) and relative humidity of ~~50~~50 % ± 10 % for at least 24 h prior to testing.

9. Animals

9.1 The test animals shall be inbred 3 month to 4 month old male rats obtained from a reputable supplier that certifies its animals to be free of major respiratory pathogens. Appropriate weight ranges at the time of use are ~~225~~225 g to 325 g for Fischer 344 rats and ~~300~~300 g to 375 g for Sprague-Dawley rats.

9.2 The maintenance and care of animals shall be performed by qualified personnel in accordance with guidelines of the National Institutes of Health Guide for the Care and Use of Laboratory Animals (2).⁵ The animal housing facilities shall be suitable for studies of this type.

9.3 The animals shall be identified, weighed, and housed upon receipt in a separate quarantine area for a minimum of seven days prior to testing. The animals shall be weighed and observed daily during the quarantine period. Animals that are unsuitable by reason of size, health, or other criteria are not to be used. Cage assignments shall be made according to a randomization routine.

9.4 The animals shall be housed one to a cage. The environment shall have proper ventilation and be controlled to a temperature of ~~23~~23 °C ± 3 °C (~~73~~73 °F ± 5 °F) and have a relative humidity of ~~50~~50 % ± 15 %. The animal room shall have a 12-h light/dark cycle.

9.5 Animals are to be weighed daily from the day of arrival to the end of the 14-day postexposure observation period. Normally, one rat in five are to be used as controls.

9.6 The animals shall be weighed prior to exposure and be secured in individual restrainers for placement in the animal exposure chamber.

9.7 After testing, surviving animals shall be housed in an animal room separate from the pretest animal room for the postexposure observation period.

10. Calibration of Apparatus

10.1 The following parts of the test apparatus require calibration: radiant heaters, gas analyzers, load cell, and temperature controller (if used).

10.2 Heat Flux Calibration:

10.2.1 For heat flux calibration, secure the heat flux meter into the proper position. The target surface of the flux meter must be centered at the location equivalent, both horizontally and vertically, to that of the top of the specimen when the specimen holder is in place on the platform. (The ignitor shall be removed from its position during this procedure.) If used, set the temperature controller to the desired flux temperature and turn on the radiant heat lamps, adjusting the temperature controller until the desired irradiance (that is, 50 kW/m² ± 10 %) is achieved. If one is using manual control of the heat lamps, develop a calibration curve of heater controller setting as a function of time required to maintain the desired flux level.

10.2.2 Check the orientation of the radiant heat lamps whenever the heaters have been moved or a lamp replaced, using the following procedure. Install the heat flux calibration jig shown in Fig. 7. The top face of the calibration jig should be at the same

⁵ The boldface numbers in parentheses refer to the list of references at the end of this standard.