



## Standard Test Method for Measurement of Mass Loss and Ignitability for Screening Purposes Using a Conical Radiant Heater<sup>1</sup>

This standard is issued under the fixed designation E2102; the number immediately following the designation indicates the year of original adoption or, in the case of revision, the year of last revision. A number in parentheses indicates the year of last reapproval. A superscript epsilon ( $\epsilon$ ) indicates an editorial change since the last revision or reapproval.

### INTRODUCTION

The screening fire-test-response method described in this standard uses a radiant energy source similar to that used in the cone calorimeter, Test Method [E1354](#). However, the test method apparatus is much simpler, because it excludes measurements of oxygen consumption or of smoke obscuration, which are incorporated into the cone calorimeter to measure heat and smoke release. A fire-test-response standard describes a test method from which one or more fire-test-response characteristics can be measured, as a result of exposure to a prescribed source of heat or flame, under controlled conditions. There are many occasions, typically for initial research and development, when there is a need for screening samples of materials, products, or assemblies, using a simple test. This allows the user to verify whether certain fire-test-response characteristics of the sample fall within the expected margins. Screening tests, as related to fire, are described in fire terminology as fire-response tests performed to determine whether a material, product, or assembly (a) exhibits any unusual fire-related characteristics, (b) has certain expected fire-related characteristics, or (c) is capable of being preliminarily categorized according to the fire characteristic in question. Screening tests addressing fire properties should be chosen so that the energy input (as heat or flame) is representative of that in the fire test method for which screening is desired.

### ASTM E2102-21

#### 1. Scope\*

1.1 This fire-test-response standard provides a means of measuring mass loss and ignitability, for screening purposes, from essentially planar materials, products, or assemblies (including surface finishes), exposed to controlled levels of radiant heating, with or without an external ignitor. This test method is intended for screening purposes only.

1.2 The principal fire-test-response characteristics obtained from this test method are those associated with mass loss from the specimens tested, as a function of time. Time to sustained flaming is also determined. Heat release is, optionally, determined using thermopile measurements detailed in [Annex A2](#).

1.2.1 The fire-test-response characteristics obtained from this test are best used for comparisons between materials with some similarities in composition or structure.

1.3 The relationship between mass loss and heat release depends on the material, product, or assembly tested, and no universal formula exists for calculation of heat release using mass loss measurements (see also additional limitations in [5.7](#)).

<sup>1</sup> This test method is under the jurisdiction of ASTM Committee E05 on Fire Standards and is the direct responsibility of Subcommittee E05.21 on Smoke and Combustion Products.

Current edition approved July 1, 2017/Dec. 1, 2021. Published August 2017/January 2022. Originally approved in 2000. Last previous edition approved in 2015/2017 as ~~E2102 – 15~~ E2102 – 17. DOI: [10.1520/E2102-17](https://doi.org/10.1520/E2102-17); [10.1520/E2102-21](https://doi.org/10.1520/E2102-21).

\*A Summary of Changes section appears at the end of this standard

1.4 The fire-test-response characteristics obtained from this test method are also obtainable with the apparatus used in Test Method E1354 (the cone calorimeter) or in an applications standards of that equipment (see also 5.4). The referenced test methods permit measurements of added fire-test-response characteristics.

1.5 The fire-test-response characteristics obtained by this test method are specific to the specimen tested, in the form and thickness tested, and are not an inherent property of the material, product, or assembly.

1.6 This fire-test-response method does not provide information on the fire performance of the test specimens under fire conditions other than those conditions specified in this test method. For additional limitations of this test method, see 5.7.

1.7 Use the SI system of units in referee decisions; see IEEE/ASTM SI-10. The units given in parentheses are for information only.

1.8 This standard is used to measure and describe the response of materials, products, or assemblies to heat and flame under controlled conditions, but does not by itself incorporate all factors required for fire hazard or fire risk assessment of the materials, products, or assemblies under actual fire conditions.

1.9 *Fire testing is inherently hazardous. Adequate safeguards for personnel and property shall be employed in conducting these tests.* See also Section 7.

1.10 *This standard does not purport to address all of the safety concerns, if any, associated with its use. It is the responsibility of the user of this standard to establish appropriate ~~safety~~ safety, health, and ~~health~~ environmental practices and determine the applicability of regulatory limitations prior to use.*

1.11 *This international standard was developed in accordance with internationally recognized principles on standardization established in the Decision on Principles for the Development of International Standards, Guides and Recommendations issued by the World Trade Organization Technical Barriers to Trade (TBT) Committee.*

## 2. Referenced Documents

### 2.1 ASTM Standards:<sup>2</sup>

- D5537 Test Method for Heat Release, Flame Spread, Smoke Obscuration, and Mass Loss Testing of Insulating Materials Contained in Electrical or Optical Fiber Cables When Burning in a Vertical Cable Tray Configuration
- D6113 Test Method for Using Cone Calorimeter to Determine Fire-Test-Response Characteristics of Insulating Materials Contained in Electrical or Optical Fiber Cables
- E176 Terminology of Fire Standards
- E535 Practice for Preparation of Fire-Test-Response Standards
- E603 Guide for Room Fire Experiments
- E638 Test Method for Calibration of Heat Transfer Rate Calorimeters Using a Narrow-Angle Blackbody Radiation Facility (Withdrawn 2001)<sup>3</sup>
- E906 Test Method for Heat and Visible Smoke Release Rates for Materials and Products Using a Thermopile Method
- E1354 Test Method for Heat and Visible Smoke Release Rates for Materials and Products Using an Oxygen Consumption Calorimeter
- E1474 Test Method for Determining the Heat Release Rate of Upholstered Furniture and Mattress Components or Composites Using a Bench Scale Oxygen Consumption Calorimeter
- E1537 Test Method for Fire Testing of Upholstered Furniture
- E1590 Test Method for Fire Testing of Mattresses
- E1623 Test Method for Determination of Fire and Thermal Parameters of Materials, Products, and Systems Using an Intermediate Scale Calorimeter (ICAL)
- E1740 Test Method for Determining the Heat Release Rate and Other Fire-Test-Response Characteristics of Wall Covering or Ceiling Covering Composites Using a Cone Calorimeter
- E1822 Test Method for Fire Testing of Stacked Chairs
- IEEE/ASTM SI-10 International System of Units (SI) The Modernized Metric System

<sup>2</sup> For referenced ASTM standards, visit the ASTM website, www.astm.org, or contact ASTM Customer Service at service@astm.org. For *Annual Book of ASTM Standards* volume information, refer to the standard's Document Summary page on the ASTM website.

<sup>3</sup> The last approved version of this historical standard is referenced on www.astm.org.

## 2.2 ISO Standards:<sup>4</sup>

ISO 3261 Fire Tests–Vocabulary

ISO 5657 Fire Tests–Reaction to Fire–Ignitability of Building Products

ISO 5660-1 Fire Tests–Reaction to Fire–Rate of Heat Release from Building Products (Cone calorimeter method)

ISO 9705 Fire Tests–Full Scale Room Test for Surface Products

ISO 13943 Fire Safety Vocabulary

## 2.3 British Standards:<sup>5</sup>

BS 476, Part 15, Fire Tests– Reaction to Fire–Rate of Heat Release from Building Products (Cone calorimeter method)

BS 6809 Method of Calibration of Radiometers for Use in Fire Testing

## 3. Terminology

3.1 *Definitions:* For definitions of terms used in this test method refer to the terminology contained in Terminology E176, ISO 3261 and ISO 13943. In case of conflict, the definitions given in Terminology E176 shall prevail.

3.2 *Definitions of Terms Specific to This Standard:*

3.2.1 *assembly, n*—a unit or structure composed of a combination of materials or products, or both.

3.2.2 *continuous* (as related to data acquisition), *adj*—conducted at data collection intervals of 5 s or less.

3.2.3 *critical heat flux for ignition, n*—the midpoint within the range of heat fluxes between the maximum (highest) heat flux that produces no ignition and the minimum (lowest) heat flux that produces ignition, for a specified exposure time.

3.2.4 *essentially flat surface, n*—surface where the irregularity from a plane does not exceed  $\pm 1$  mm.

3.2.5 *exposed surface, n*—that surface of the specimen subjected to the incident heat.

3.2.6 *flashing, n*—existence of flame on or over the surface of the specimen for periods of less than 1 s.

3.2.7 *irradiance* (at a point of a surface), *n*—ratio of the radiant flux incident on a small but measurable element of surface containing the point, by the area of that element.

3.2.7.1 *Discussion—*

Convective heating is negligible in the horizontal specimen orientation. In the vertical orientation, it is small, but not negligible. Despite this contribution from convective heating, the term “irradiance” is used instead of “heat flux” throughout this test method as it best indicates the essentially radiative mode of heat transfer.

3.2.8 *material, n*—single substance, or uniformly dispersed mixture, for example metal, stone, timber, concrete, mineral fiber, or polymer.

3.2.9 *orientation, n*—the plane in which the exposed face of the specimen is located during testing.

3.2.9.1 *Discussion—*

For this standard, the specimen orientation may only be either vertical or horizontal.

3.2.10 *sample, n*—an amount of the material, product, or assembly, to be tested, which is representative of the item as a whole.

3.2.11 *specimen, n*—representative piece of the product which is to be tested together with any substrate or treatment.

3.2.11.1 *Discussion—*

This may include an air gap.

3.2.12 *sustained flaming, n*—the existence of flame on or over the surface of the specimen for a period of 4 s or more.

3.2.13 *time to ignition, n*—time between the start of the test and the presence of a flame on or over most of the specimen surface for a period of at least 4 s.

<sup>4</sup> Available from International Standardization Organization, P.O. Box 56, CH-1211; Geneva 20, Switzerland or American National Standards Institute (ANSI), 25 W. 43rd St., 4th Floor, New York, NY 10036.

<sup>5</sup> Available from British Standards Institution, PO Box 4033, Linford Wood, Milton Keynes, MK 14 6LE, United Kingdom

3.2.14 *time to sustained flaming, n*—time to ignition.

3.2.15 *transitory flaming, n*—the existence of flame on or over the surface of the specimen for periods of between 1 and 4 s.

#### 4. Summary of Test Method

4.1 This test method employs a conically-shaped electrically-heated radiant-energy source, positioned so as to produce an irradiance level of up to 100 kW/m<sup>2</sup>, averaged over the center of the exposed surface of an essentially planar specimen. An external spark ignitor is available, if required. This test method is used to determine continuously the mass lost during the combustion process, using a load cell, for screening purposes. Ignitability is also assessed by the test method.

4.1.1 Optionally, the test method is capable of obtaining an estimate of the heat released by the specimen during the burning process, using a thermopile housed above the burning specimen (See [Annex A2](#)). Determinations of heat release using a similar radiant-energy source and oxygen consumption calorimetry, are made with the cone calorimeter, Test Method [E1354](#).

4.2 The specimen is essentially planar, 100 mm by 100 mm (3.9(3.9 in. by 3.9 in.) in size, at a thickness not exceeding 25 mm (1 in.) and is mounted within a holder.

#### 5. Significance and Use

5.1 This test method provides a means for screening materials, products, or assemblies, for the mass loss, and ignitability they exhibit under specified heat flux exposure conditions. As an option, the test method is also suitable for screening for the heat released, by using a thermopile method (See [Annex A2](#)).

5.1.1 Terminology [E176](#), on fire standards, states that fire-test-response characteristics include ease of ignition and mass loss (both measured in this test method), as well as flame spread, smoke generation, fire endurance, and toxic potency of smoke.

5.1.2 The mass loss rate of a material, product, or assembly is a fire-test-response characteristic that gives an indication of its burning rate. Thus, a lower mass loss rate is often associated with slower burning. Note, however, that mass loss is not always a result of combustion, and that this method does not assess release of smoke or combustion products.

5.1.3 The time to ignition of a material, product, or assembly is a fire-test-response characteristic that gives an indication of its propensity to ignite at the applied heat flux level and subsequently to release heat and spread flame over its surface. Thus, a longer time to ignition is an indication of a lower propensity for the material, product, or assembly to become involved and contribute to fire spread or growth; however this method does not assess the smoke or combustion products released.

5.1.4 The apparatus used for this test method is suitable to assess the critical heat flux for ignition of the materials, products, or assemblies tested, by assessing ignitability at various heat fluxes (see [Appendix X3](#) for guidance).

5.2 Values determined by this test are specific to the specimen in the form and thickness tested and are not inherent fundamental properties of the material, product, or assembly tested. Thus, closely repeatable or reproducible experimental results are not to be expected from this test method when tests are conducted for a given material, product, or assembly, while introducing variations in properties such as specimen thickness or density.

5.3 No incident irradiance is specified in this test method. The instrument is capable of generating irradiances ranging up to 100 kW/m<sup>2</sup>. The choice of irradiance is a function of the application of the material, product, or assembly to be tested, and of the fire scenario the user is investigating. However, the method is not suitable for incident irradiances below ~~40~~ 10 kW/m<sup>2</sup> (see [5.7.3](#)).

5.4 The method used for optionally measuring heat release, a thermopile, is not as accurate as the conventional oxygen consumption calorimetry method, used in the cone calorimeter, Test Method [E1354](#), in its applications standards, such as Test Method [E1474](#) and [E1740](#), or in intermediate scale or a large scale calorimetry test methods, such as Test Methods [E1623](#), [E1537](#),

E1590 or D5537 (see also Annex A2). On the other hand the thermopile method of assessing heat release has been used extensively because of its simplicity, including Test Method E906, and other applications discussed in Guide E603.<sup>6</sup>

5.5 Testing of composites and dimensionally unstable materials requires special procedures (see 8.4 and 8.5).

5.6 Testing in the vertical orientation is feasible with the test method, but not recommended, as it has been shown to have the potential to lead to serious measurement errors on time to ignition.

5.7 Limitations

5.7.1 No universal formula exists for calculation of heat release as a function of mass loss. If heat release data are desired, calibration curves must be developed by the user, and they are specific to the material, product, or assembly tested.

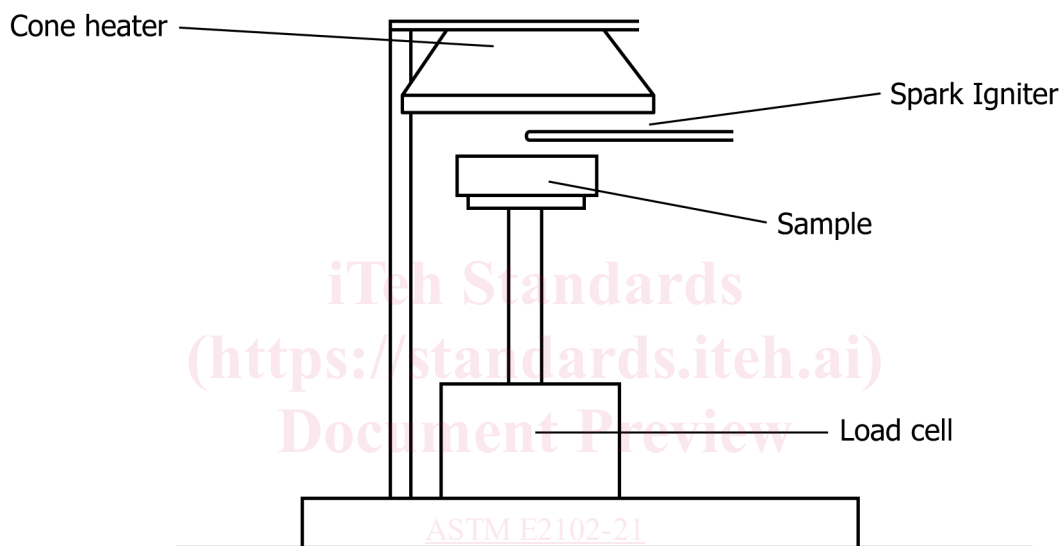

FIG. 1 Schematic of Apparatus

5.7.2 If during the test of one or more of the three replicate test specimens, any of the following unusual behavior occurs: (1) molten material overflows the specimen holder trough, (2) one or more portions of a test specimen is forcefully displaced from the zone of controlled irradiance (explosive spalling); or (3) the test specimen swells sufficiently prior to ignition to touch the spark plug or swells up to the plane of the heater base during combustion; the test is invalid. Then test an additional specimen of the identical preconditioned test specimens in the test mode in which the unusual behavior occurred. Do not incorporate data obtained from the tests noted above, yielding inadequate results, in the averaged data but report the occurrence. The test method is not suitable if more than three out of six test specimens tested show any of the above characteristics.

5.7.3 The applicability of this test method to smoldering ignition has not been demonstrated. This test method is not suitable for incident irradiances below 10 kW/m<sup>2</sup>.

5.7.4 The validity of the results of this test method for a particular scenario depends on the conditions under which the tests are conducted. In particular, it has been established that the use of a different irradiance will change relative results

5.7.5 The thermopile readings, if used, are likely not to be reflective of the heat output of the burning specimen if the flames extend to the thermopile.

<sup>6</sup> Note that this section refers to accuracy of measurement, and not to precision. The precision of this test method has not yet been determined.

5.8 In this procedure, the specimens are subjected to one or more specific sets of laboratory test conditions. If different test conditions are substituted or the end-use conditions are changed, it is not always possible by or from this test method to predict changes in the fire-test-response characteristics measured. Therefore, the results are valid only for the fire test exposure conditions described in this procedure.

NOTE 1—This statement is required for all fire-test-response standards by Practice E535.

## 6. Apparatus and Ancillary Equipment

6.1 *General*—The apparatus shall consist essentially of the following components: a conically-shaped radiant heater, a load cell, a specimen holder and an exhaust system. A schematic representation of the apparatus is given in Fig. 1. The individual components are described in sections 6.2 – 6.11. Unless otherwise stated, dimensions specified as critical shall have a tolerance of  $\pm 1$  mm (0.04 in.). All other dimensions are only recommended values.

6.2 *Conically-Shaped Radiant Electrical Heater*—The active element of the heater shall consist of an electrical heater rod, capable of delivering 5000 W at the operating voltage, tightly wound into the shape of a truncated cone (see Fig. 2). The heater shall be encased on the outside with a double-wall stainless steel<sup>7</sup> cone, filled with a refractory blanket of nominal thickness 13 mm (0.5 in.) and nominal density 100 kg/m<sup>3</sup> (6 lb/ft<sup>3</sup>). The irradiance from the heater shall be maintained at a preset level by controlling the average temperature of three type K, stainless steel sheathed thermocouples, symmetrically disposed and in contact with, but not welded to, the heater element (see Fig. 2). The thermocouples to be used shall be either 3 mm (0.12 in.) outside diameter sheathed thermocouples with exposed hot junction or  $\pm 0.10$  mm to 1.6 mm (0.04 to 0.06 in.) outside diameter sheathed thermocouples with unexposed hot junction. The heater shall be capable of producing irradiances on the surface of the specimen of up to 100 kW/m<sup>2</sup>. The irradiance shall be uniform within the central 50 mm by 50 mm (2 in. by 2 in.) area of the exposed specimen surface, to within  $\pm 2 \pm 2$  %.

6.2.1 The cone heater shall be provided with a removable radiation shield to protect the specimen from irradiance immediately prior to the start of the test. The shield shall protect the specimen so that the irradiance to the specimen in its presence is decreased by 90% within  $\pm 10$  s and that the irradiance after shield withdrawal does not differ by more than 1 kW/m<sup>2</sup> from the value calibrated. The radiation shield shall be made of non-combustible material, with a total thickness not to exceed 12 mm. The radiation shield shall comply with either 6.2.1.1 or 6.2.1.2 and shall be kept in place for a maximum period of  $\pm 10$  s.<sup>8</sup>

6.2.1.1 A water-cooled radiation shield coated with a durable matte black finish of surface emissivity  $e = 0.95 \pm 0.05$  (Type I Shield); or

6.2.1.2 A radiation shield with a reflective top surface in order to minimize radiation transfer, but not water-cooled (Type II Shield).

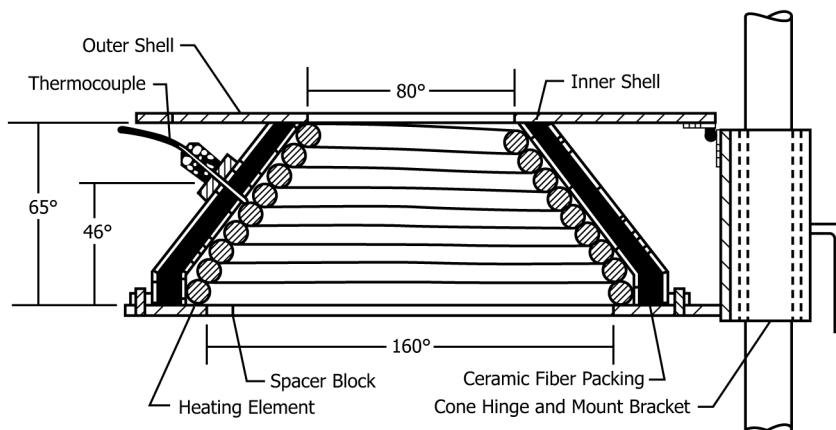

FIG. 2 Cross-Section View Through the Heater

<sup>7</sup> Stainless steel can be replaced by a different alloy that offers at least the same protection to hot and corrosive environments.

<sup>8</sup> It is possible that the use of a radiation shield for periods longer than 10 s will affect radiator heat control and, consequently, the heat flux level applied to the specimen.

6.2.1.3 The radiation shield shall be equipped with a handle or other suitable means for quick insertion and removal. The cone heater base plate shall be equipped with the means for holding the radiation shield in position and allowing its easy and quick removal.<sup>9</sup>

6.3 *Irradiance Controller*—The irradiance control system shall maintain the average temperature of the heater thermocouples during calibration at the preset level to within  $\pm 2^{\circ}\text{C}$ ;  $\pm 2^{\circ}\text{C}$ .

6.3.1 An acceptable system is a “3-term” controller (proportional, integral, and derivative) and a thyristor unit capable of switching currents up to 25 A at 250 V.

6.3.2 The controller shall have a temperature input range of  $0^{\circ}\text{C}$  to  $1000^{\circ}\text{C}$  ( $32^{\circ}\text{F}$  to  $1832^{\circ}\text{F}$ ), a set scale capable of being read to  $2^{\circ}\text{C}$  ( $5^{\circ}\text{F}$ ) or better, and automatic cold junction compensation. The controller shall be equipped with a safety feature so that, in the event of an open circuit in the thermocouple line, it causes the temperature to fall to near the bottom of its range.

6.3.3 The thyristor unit shall be of the “zero crossing” type and not of the “phase angle” type.

6.3.4 The heater temperature shall be monitored by a meter capable of being read to  $\pm 2^{\circ}\text{C}$  ( $5^{\circ}\text{F}$ ) or better.

6.4 *Weighing Device*, for measuring mass loss. The device shall have an accuracy of 0.1 g, and a 90% response time of less than 3 s, as determined in accordance with the calibrations described in 10.2. It should preferably have a specimen measuring range of at least 500 g and a mechanical tare adjustment range of 3.5 kg (7.7 lb).

6.5 *Specimen Holder*:

6.5.1 The specimen holder is shown in Fig. 3. It shall have the shape of a square pan with an opening of outside dimensions of  $106 \pm 0.1 \text{ mm}$  by 106 mm ( $4.2 \pm 0.004 \text{ in.}$  by 4.2 in.) at the top, and a depth of 25 mm (1 in.). The holder shall be constructed from stainless steel with a thickness of  $2.4 \pm 0.1 \text{ mm}$  ( $0.094 \pm 0.004 \text{ in.}$ ). It shall include a handle to facilitate insertion and removal, and a mechanism to ensure central location of the specimen under the heater and proper alignment with the weighing device. The bottom shall be lined with a layer of a low density (nominal density  $65 \text{ kg/m}^3$  ( $4 \text{ lb/ft}^3$ )) refractory fiber blanket with thickness of at least 13 mm (0.5 in.). The distance between the bottom surface of the cone heater and the top of the specimen shall be adjusted to be 25 mm (1 in.).

6.5.1.1 An open stainless steel square, 59 mm in inside dimensions, shall be spot welded to the underside of the horizontal specimen holder, to facilitate the centering of the specimen under the cone heater. The leading edge of the open square underneath the specimen holder, which is the one opposite the handle, is optional. The open square on the bottom of the specimen holder shall be designed to seat with the sample mount assembly located at the top of the load cell ensuring that the specimen holder is centered with respect to the cone heater.

6.5.2 An optional retainer frame and grid is useful for testing some samples, and is shown in Fig. 4. The grid is constructed from 1 mm nominal stainless steel and has dimensions of  $109 \pm 2 \text{ mm}$  by 109 mm ( $\pm 2 \text{ mm}$ ). The grid has  $1 \text{ mm}$  ribs and the openings in the center are  $19 \pm 1 \text{ mm}$  by 19 mm ( $\pm 1 \text{ mm}$ ). The edge frame is constructed from 2 mm nominal stainless steel with outside dimensions of  $116 \pm 2 \text{ mm}$  by  $116 \pm 2 \text{ mm}$  by 56 mm height ( $\pm 2 \text{ mm}$ ). The frame has an 8 mm lip on the top to provide an opening of  $100 \pm 0.5 \text{ mm}$  by 100 mm on the top. There are two 3 mm ( $\pm 0.5 \text{ mm}$ ) diameter by 130 mm ( $\pm 3 \text{ mm}$ ) long retaining pins to lock the test specimen in the edge frame.

6.5.3 Details on specimen preparation are given in 9.3.

6.6 *Exhaust Gas System*. Use the instrument under a hood with adequate ventilation to safely remove all combustion products from the laboratory.

6.7 *Ignition Circuit*—External ignition is accomplished by a spark plug powered from a  $10 \text{ kV}$  transformer or a  $10 \text{ kV}$  spark generator. The spark plug shall have a gap of 3 mm (0.12 in.). If used, the transformer shall be of a type specifically designed

<sup>9</sup> This device is necessary in order to enable repeat tests to be carried out without switching off the radiator cone.

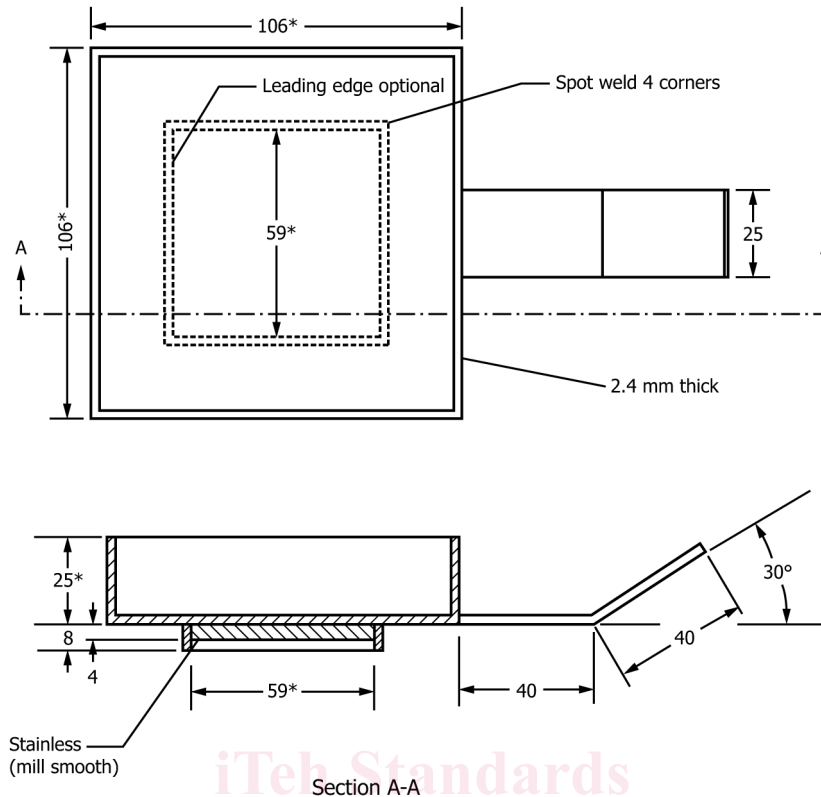

NOTE 1—All dimensions are in millimetres.

NOTE 2—\* Indicates a critical dimension.

FIG. 3 Horizontal Specimen Holder

for spark ignition use. The transformer shall have an isolated (unearthed) secondary to minimize interference with the data transmission lines. The electrode length and location of the spark plug shall be such that the spark gap is located 13 mm (0.5 in.) above the center of the specimen, in the horizontal orientation.

6.8 *Ignition Timer*—It shall be capable of recording elapsed time to the nearest 1 s, and shall be accurate to within 1 s in 1 h.

6.9 *Heat Flux Meter:*

6.9.1 The heat flux meter shall be of the Schmidt-Boelter (thermopile) type, with a design range of about 100 kW/m<sup>2</sup>. The sensing surface of the heat flux meter shall be fiat, circular, of approximately ~~12.5 mm~~ 12.5 mm (0.5 in.) in diameter and coated with a durable matt black finish.<sup>10</sup> The target shall be water-cooled, to the temperature at which it was calibrated, at least at room temperature in the laboratory.<sup>11</sup> Radiation shall not pass through any window before reaching the sensing surface. The instrument shall have an accuracy of within  $\pm 3\%$ .

6.9.2 The calibration of the heat flux meter shall be checked, whenever a recalibration of the apparatus is carried out, by comparison with two instruments of the same type as the working heat flux meter, and of similar range, held as reference standards and not used for any other purpose (see Annex A1). One of the reference standards shall be fully calibrated at a standardizing laboratory, at yearly intervals. This meter shall be used to calibrate the heater. It shall be positioned at a location equivalent to the center of the specimen face, in either orientation, during this calibration.

6.10 *Calibration Burner*—A calibration burner shall be used to calibrate the rate of heat release apparatus (see Fig. 5). The burner shall be constructed from a square-section metallic tube, with a square orifice covered with wire gauze through which methane gas

<sup>10</sup> The target also receives, to a small extent, some convected heat.

<sup>11</sup> If the cooling temperature is lower than the temperature at which the gage is calibrated, condensation on the sensor is possible and would lead to serious measurement errors.



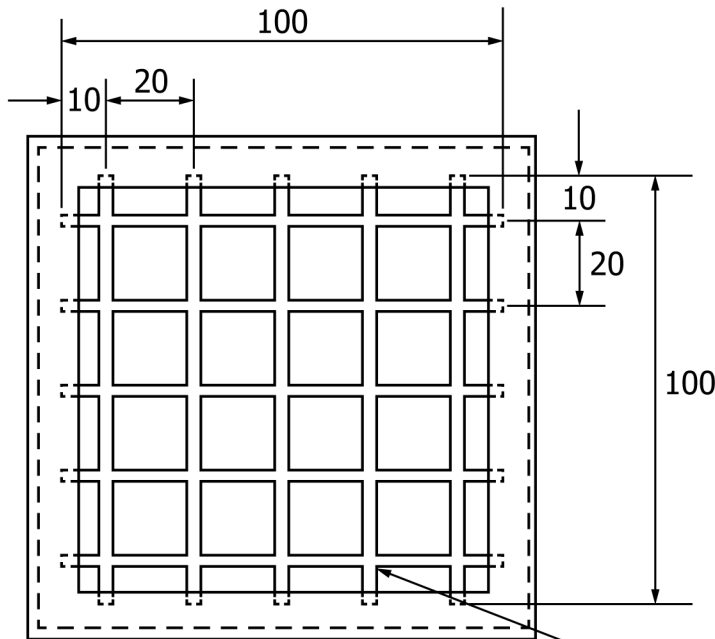

Sample retaining grid (optional)  
 For use with samples that are expected to intumesce.  
 Material: 2 mm stainless steel rod  
 Weld all intersections

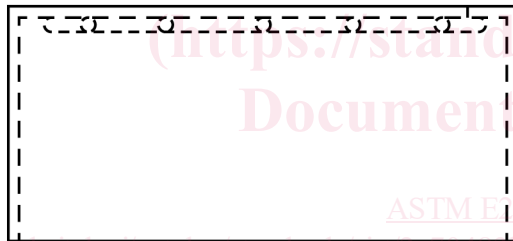

Material: Stainless steel, 1.9 mm thick

FIG. 4 Optional Wire Grid (For Horizontal or Vertical Orientation)

diffuses. The tube shall be packed with ceramic fiber to improve uniformity of flow. The calibration burner shall be connected to a metered supply of methane, with a purity of at least 99.5 percent.

6.11 *Data Acquisition System*—The data acquisition system shall have facilities to record the output from the load cell and from the thermopile (if used). The data acquisition system shall have an accuracy of  $\pm 0.01\%$  of full-scale load cell output. The system shall be capable of recording data at least every 5 s for a minimum of 1 h. A chart recorder is an acceptable system, if it meets the accuracy required and the minimum chart speed used is no less than 10 mm/min (0.4 (0.4 in. in./min)/min).<sup>12</sup>

## 7. Operator Safety

7.1 The test procedure involves high temperatures, and combustion processes. Therefore, it is possible for eye injuries, burns, ignition of extraneous objects or clothing, and inhalation of smoke or combustion products to occur, unless proper precautions are taken. To avoid accidental leakage of toxic combustion products into the surrounding atmosphere, it is advisable to fully evacuate the smoke, at the end of a test, into an exhaust system with adequate capacity. The operator must use heavy gloves, safety tongs or other suitable protection for removal of the specimen holder. The venting must be checked periodically for proper operation.

<sup>12</sup> If a chart recorder which only displays a millivolt output is used, the millivolt value shall be converted to heat flux, in kW/m<sup>2</sup>, using the calibration factor (or equation, if appropriate) specific to the heat flux meter.

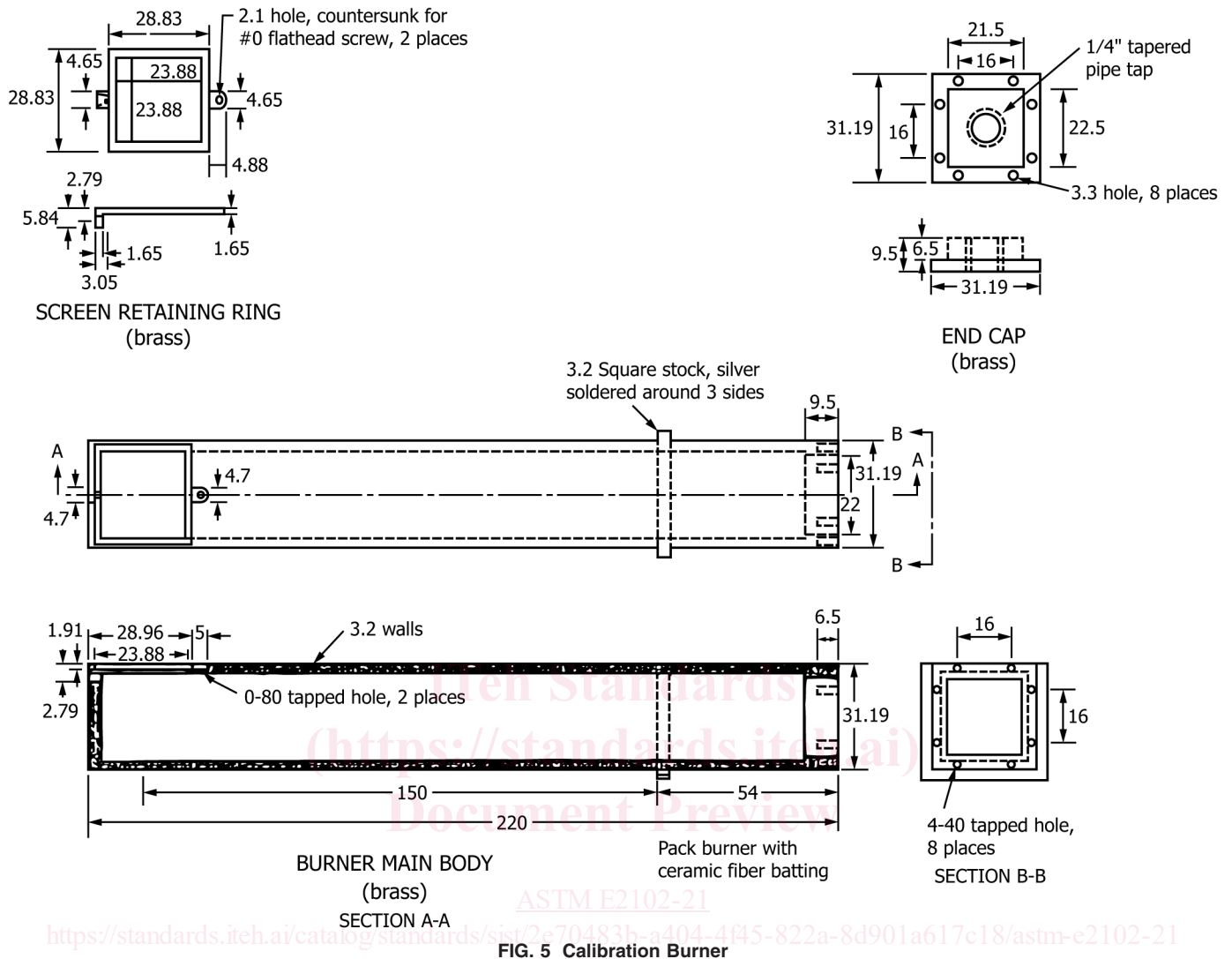

FIG. 5 Calibration Burner

Care shall be taken not to touch the spark igniter, which carries a substantial potential ( $\pm 10$  kV), during operation. The exhaust system of the apparatus shall be checked for proper operation before testing and shall discharge into a building exhaust system with adequate capacity. The possibility of the violent ejection of molten hot material or sharp fragments from some kinds of specimens when irradiated must be taken into account.

## 8. Suitability of a Sample for Testing

8.1 *Surface Characteristics*—A product having one of the properties described in 8.1.1 or 8.1.2 is suitable for testing.

8.1.1 An essentially flat exposed surface (see 3.2.4).

8.1.2 A surface irregularity which is evenly distributed over the exposed surface provided that it complies with either 8.1.2.1 or 8.1.2.2.

8.1.2.1 At least 50 % of the surface of a representative square area of 100 mm (4 in.) per side lies within a depth of  $\pm 10$  mm (0.4 in.) from a plane taken across the highest points on the exposed surface.

8.1.2.2 The total area of any cracks, fissures or holes does not exceed 30 % of a representative square area 100 mm (4 in.) per side of the exposed surface, and none of the cracks, fissures or holes exceeds 8 mm (0.3 in.) in width nor 10 mm (0.4 in.) in depth.

8.1.2.3 When an exposed surface does not meet the requirements of 8.1.1 or 8.1.2, the product shall be tested in a modified form

complying as nearly as possible with the requirements given in 8.1.2. The test report shall then state that the sample has been tested in a modified form and clearly describe the modification.

8.2 *Asymmetrical Products*—A sample submitted for this test is permitted to have faces which differ from each other, or contain laminations of different materials arranged in a different order in relation to the two faces. If either of the faces is potentially exposed to a fire in use within a room, cavity or void, then both faces shall be tested.

8.3 *Lightweight Materials*—This test method is not suitable, unless modified, for materials that are excessively low in weight, since it is likely that insufficient mass loss data will be collected for the calculation of mass loss rates. For some samples, this problem is solved by using a lower data acquisition interval, such as 1 s; the test report shall then state that the sample has been tested in a modified form and clearly describe the modification.

8.4 *Composite Specimens*—Composite specimens shall be exposed in a manner typical of the end use condition (for example, if used with an air gap (see 9.1.7), and air gap shall be included behind the specimen, within the aluminum foil). Use a metal spacer frame to achieve the air gap.

8.5 *Dimensionally Unstable Materials*—Testing of materials that change their dimensions substantially when exposed to the radiant heat from the cone require special procedures. This section addresses materials that intumesce (and have the potential to expand to such an extent that they make physical contact with the spark igniter or the underside of the cone heater; see 8.5.1), materials that melt (and have the potential to overflow the aluminum foil; see 8.5.2) and materials that warp (and have the potential to shrink away from the cone heater; see 8.5.3). In all these cases, it is possible that the heat flux on the surface of the specimen at the time of ignition will differ from the initial test heat flux.

8.5.1 *Intumescent Materials*—The testing technique to be used when testing intumescent specimens shall be documented in detail in the test report. Options include those shown in 8.5.1.1 through 8.5.1.4.

8.5.1.1 Use a retainer frame without a grid (Fig. 6), to reduce unrepresentative edge burning of specimens.

8.5.1.2 Use a retainer frame with a wire grid (Fig. 4), which is suitable for retaining specimens prone to delamination and for several types of intumescent specimens.

8.5.1.3 Use a separation distance between the cone base plate and the upper specimen surface of 60 mm instead of ~~25 mm~~, 25 mm, without using a retainer frame. Use this technique for those dimensionally unstable materials that have the potential to intumesce or deform to such an extent that they are likely to make physical contact with either (a) the spark plug before ignition, or (b) the underside of the cone heater after ignition. In this configuration, the spark igniter will be located ~~48~~48 mm ± 2 mm above the center of the specimen.

NOTE 2—The time to ignition measured with the ~~60 mm~~60 mm separation is not comparable to that measured with the standard separation of 25 mm.

8.5.1.4 Use a special mounting procedure suitable for the specimen to be tested.

8.5.2 *Melting Materials:*

8.5.2.1 Materials that melt and overflow the aluminum foil wrapping during testing shall be tested using aluminum foil that extends above the specimen surface level. The aluminum foil extension above the specimen surface shall be such that melt overflow is contained, without interfering with the combustion process. A height of ~~2-3~~2 mm to 3 mm is recommended.

8.5.2.2 If a test has been conducted without using the special technique described in 8.5.2.1 and melt overflow has occurred, that test shall be deemed invalid and the technique in 8.5.2.1 shall be used for future tests.

8.5.3 *Warping Materials*—Unstable materials that warp so that the exposed surface of the test specimen is not flat during testing shall be restrained to maintain the surface in a flat orientation. This shall be accomplished with four tie wires, as described in 8.5.3.1 through 8.5.3.4.

8.5.3.1 The four tie wires shall be metal wires, ~~±~~0.1 mm ± 0.1 mm in diameter and at least 350 mm long.

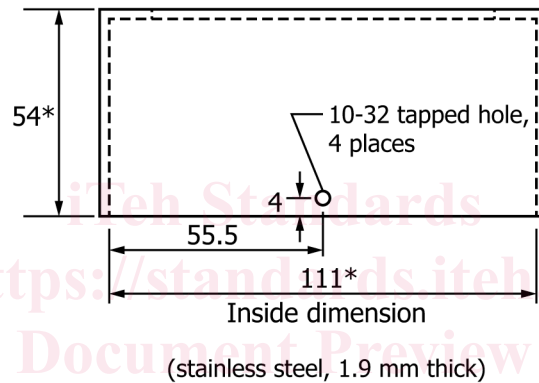
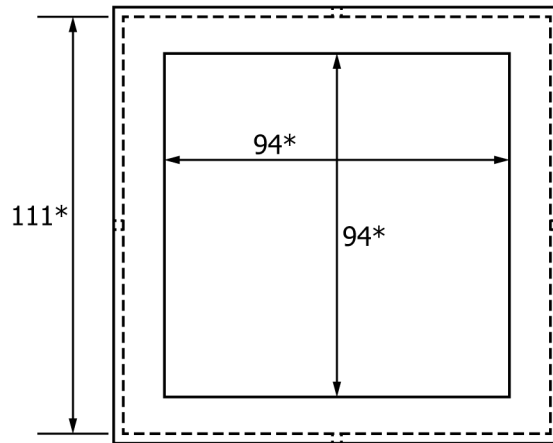

NOTE 1—All dimensions are in millimeters.  
NOTE 2—\* Indicates a critical dimension.

FIG. 6 Retainer Frame

(stainless steel, 1.9 mm thick)

8.5.3.2 The test specimen shall be prepared as described in Section 9 and then tied with the metal wires.

8.5.3.3 A tie wire shall be looped around the specimen holder assembly so that it is parallel to and  $20 \pm 2$  mm away from any of the four sides of the assembly. The ends of the tie wire shall be twisted together such that the wire is pulled firmly against the specimen holder assembly. Trim excess wire from the twisted section before testing.

8.5.3.4 Fit the other three tie wires around the specimen holder assembly in a similar manner, so that each one is parallel to one of the sides of the assembly.

## 9. Test Specimen

### 9.1 Types of Test Specimens:

9.1.1 Unless otherwise specified, three specimens shall be tested at each level of irradiance selected and for each different exposed surface.

9.1.2 The specimens shall be representative of the product and shall be square with sides measuring  $100 \pm 0.5$  mm ( $3.9 \pm 0.2$  in.).

9.1.3 Samples with normal thicknesses of 50 mm (2 in.) or less shall be tested at their full thickness.