



Designation: D1831 – 21

## Standard Test Method for Roll Stability of Lubricating Grease<sup>1</sup>

This standard is issued under the fixed designation D1831; the number immediately following the designation indicates the year of original adoption or, in the case of revision, the year of last revision. A number in parentheses indicates the year of last reapproval. A superscript epsilon ( $\epsilon$ ) indicates an editorial change since the last revision or reapproval.

*This standard has been approved for use by agencies of the U.S. Department of Defense.*

### 1. Scope\*

1.1 This test method covers determination of the changes in the consistency, as measured by cone penetration, of lubricating greases when worked in the roll stability test apparatus.

1.2 The values stated in SI units are to be regarded as standard. The values given in parentheses after SI units are provided for information only and are not considered standard.

1.3 *This standard does not purport to address all of the safety concerns, if any, associated with its use. It is the responsibility of the user of this standard to establish appropriate safety, health, and environmental practices and determine the applicability of regulatory limitations prior to use.*

1.4 *This international standard was developed in accordance with internationally recognized principles on standardization established in the Decision on Principles for the Development of International Standards, Guides and Recommendations issued by the World Trade Organization Technical Barriers to Trade (TBT) Committee.*

### 2. Referenced Documents

2.1 *ASTM Standards:*<sup>2</sup>

[D217 Test Methods for Cone Penetration of Lubricating Grease](#)

[D1403 Test Methods for Cone Penetration of Lubricating Grease Using One-Quarter and One-Half Scale Cone Equipment](#)

### 3. Terminology

3.1 *Definitions:*

3.1.1 *consistency, n—of lubricating grease*, the degree of resistance to movement under stress.

<sup>1</sup> This test method is under the jurisdiction of ASTM Committee D02 on Petroleum Products, Liquid Fuels, and Lubricants and is the direct responsibility of Subcommittee D02.G0.02 on Consistency and Related Rheological Tests.

Current edition approved Dec. 1, 2021. Published January 2022. Originally approved in 1961. Last previous edition approved in 2020 as D1831 – 20. DOI: 10.1520/D1831-21.

<sup>2</sup> For referenced ASTM standards, visit the ASTM website, [www.astm.org](http://www.astm.org), or contact ASTM Customer Service at [service@astm.org](mailto:service@astm.org). For *Annual Book of ASTM Standards* volume information, refer to the standard's Document Summary page on the ASTM website.

3.1.1.1 *Discussion*—The term consistency is used somewhat synonymously with penetration. Generally, consistency refers to the worked penetration of a grease. **D217**

3.1.2 *lubricant, n*—any material interposed between two surfaces that reduces the friction or wear between them. **D217**

3.1.3 *lubricating grease, n*—a semi-fluid to solid product of a dispersion of a thickener in a liquid lubricant.

3.1.3.1 *Discussion*—The dispersion of the thickener forms a two-phase system and immobilizes the liquid lubricant by surface tension and other physical forces. Other ingredients imparting special properties are often included. **D217**

3.1.4 *penetration, n—of lubricating grease*, the depth that the standard cone enters the sample when released to fall under its own weight for 5 s. **D217**

3.1.5 *reduced-scale penetration, n—of lubricating grease*, the depth in units of 0.1 mm that a ¼-scale cone or ½-scale cone penetrates the sample when released to fall under its own weight for 5 s.

3.1.5.1 *Discussion*—The term reduced-scale penetration is similar to the term penetration found in Test Methods **D217**. However, due to the differences in scale, the terms are not synonymous and should not be confused.

3.1.6 *reduced-scale penetrometer, n*—an instrument similar to that shown in Fig. 1 of Test Methods **D217**, designed to measure the consistency or hardness of semi-liquid to semi-solid materials by measuring the depth to which the ¼-scale or the ½-scale cone falls into grease.

3.1.6.1 *Discussion*—Either a ¼-scale cone or a ½-scale cone can be used to determine the consistency of lubricating greases when the quantity of sample available for testing is limited. The penetration forces are determined by the respective masses of the cones and shafts.

3.1.7 *reduced-scale worked penetration, n—of lubricating grease*, the penetration at 25 °C (77 °F), without delay, of a sample after 60 double strokes in a ¼-scale or ½-scale grease worker.

3.1.8 *thickener, n—in lubricating grease*, a substance composed of finely divided particles dispersed in a liquid lubricant to form the product's structure.

3.1.8.1 *Discussion*—The thickener can be fibers (such as

\*A Summary of Changes section appears at the end of this standard

various metallic soaps) or plates or spheres (such as certain non-soap thickeners) which are insoluble or, at the most, only very slightly soluble in the liquid lubricant. The general requirements are that the solid particles be extremely small, uniformly dispersed, and capable of forming a relatively stable, gel-like structure with the liquid lubricant. **D217**

3.1.9 *worked penetration, n—of lubricating grease*, the penetration at 25 °C (77 °F), without delay, of a sample after 60 double strokes in a standard grease worker. **D217**

3.1.10 *working, n—of lubricating grease*, the subjection of a sample to the shearing action of the standard grease worker. **D217**

3.2 *Definitions of Terms Specific to This Standard:*

3.2.1 *roll stability, n—of lubricating grease*, the change in consistency of a sample after a specified amount of working in a test apparatus utilizing a weighted roller inside a rotating cylinder.

4. Summary of Test Method

4.1 The Test Methods **D1403** reduced-scale cone penetration of an approximately 50 g aliquot of lubricating grease is determined. The grease is then subjected to low shear at 20 °C to 35 °C for 2 h ± 5 min in a standard roll stability apparatus, after which the reduced-scale cone penetration is measured. The difference between the reduced-scale cone penetration before working and the reduced-scale cone penetration after is used as a measure of the effect of low shear working on grease consistency. The same scale cone, either ¼-scale or ½-scale, should be used before and after shearing the grease sample in the roll stability test apparatus.

5. Significance and Use

5.1 The roll stability test is widely used in specifications. Test results are significant insofar as they can show a directional change in consistency that could occur in service. No

accurate correlation is established between the test results and shear stability in actual service.

6. Apparatus

6.1 *Roll Stability Test Apparatus*, capable of rotating a steel cylinder and 5 kg ± 0.05 kg roller weight at a rolling speed of 165 r/min ± 15 r/min. One such example of a suitable apparatus is shown in Fig. 1.

6.2 *¼ or ½ Scale Cone and Shaft with Worker*, as described in Test Methods **D1403**.

7. Procedure

7.1 Determine the worked penetration in accordance with Test Methods **D1403**.

7.2 Transfer 50 g ± 1 g of the unworked grease to the test cylinder. Distribute the grease uniformly on the inside wall of the cylinder with a spatula. Place the weighted roll in the cylinder and tighten the cap.

7.3 Mount the cylinder in position, start the machine, and record the time and room temperature which should be limited to 20 °C to 35 °C. If the cylinder is enclosed within a cabinet, the temperature around the cylinder shall be maintained at 20 °C to 35 °C.

7.4 After rolling for 2 h ± 5 min, remove the grease from the cylinder promptly and proceed with the requirements of reduced-scale worked penetration in Test Methods **D1403**. Record the reduced-scale worked penetration. After transferring the grease to the worker, clean the roll stability test apparatus by wiping with clean cloth or tissue.

7.5 Convert the reduced-scale penetration values determined by Test Methods **D1403** (before and after rolling) into the equivalent full scale cone penetration values using the appropriate equations described in Test Methods **D1403**.

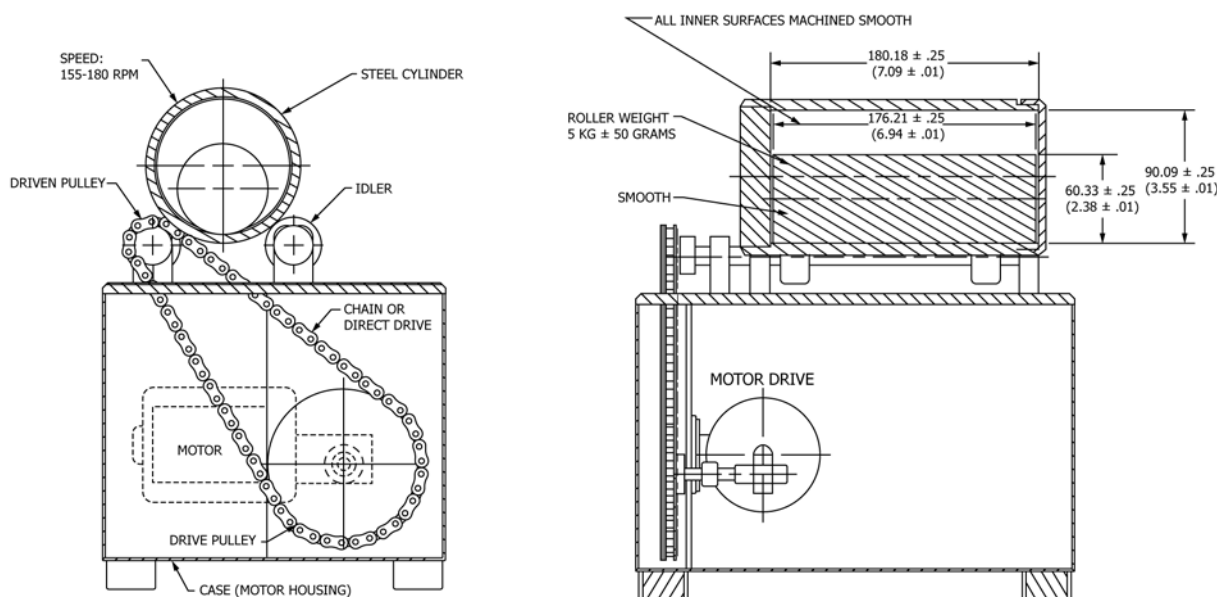

NOTE 1—All units in millimetres (inches).

FIG. 1 Roll Stability Tester