



Designation: F1359/F1359M – 22

# Standard Test Method for Liquid Penetration Resistance of Protective Clothing or Protective Ensembles Under a Shower Spray While on a Manikin<sup>1</sup>

This standard is issued under the fixed designation F1359/F1359M; the number immediately following the designation indicates the year of original adoption or, in the case of revision, the year of last revision. A number in parentheses indicates the year of last reapproval. A superscript epsilon ( $\epsilon$ ) indicates an editorial change since the last revision or reapproval.

## INTRODUCTION

Personnel in industry and emergency response can be exposed to numerous liquids capable of causing harm upon contact with the human body. These liquids may include chemicals, contaminated blood or body fluids, and other hazardous liquids. The deleterious effects of different chemicals can range from acute trauma such as skin irritation and burn, to chronic degenerative disease such as cancer. Biological-based hazard liquids may include various liquid-borne pathogens capable of causing infection directly or with non-intact skin. Since engineering controls cannot eliminate all possible exposures, attention is often placed on reducing the potential for direct skin contact through the use of protective clothing.

Protective clothing is available in a variety of constructions, configurations, and materials, and is designed to provide various levels of protection against many hazards. Protective clothing offering the highest level of chemical protection is constructed to prevent any contact of solid, liquid, or gaseous chemicals with the wearer. Test Method F1052 evaluates the integrity and construction of the vapor protective ensembles by way of an internal pressure test. In some applications, protective clothing need only isolate the wearer from splashes of liquids. This test method evaluates the integrity of the construction and configuration of liquid-penetration-resistant protective clothing or protective ensembles with a shower spray test.

Resistance of materials used in protective clothing to chemical permeation should be evaluated by Test Method F739 for continuous contact and Test Method F1383 for intermittent contact (that is, splash), or by Test Method F1407 using the permeation cup method. Resistance of protective clothing materials to liquid penetration should be determined by Test Method F903. Resistance of protective clothing materials specifically to blood and other potentially infectious materials should be determined by Test Methods F1670/F1670M and F1671/F1671M.

## 1. Scope

1.1 This test method measures the ability of protective clothing or protective ensembles to resist liquid penetration in the form of a shower spray with surfactant-treated water.

1.2 This test method measures the liquid penetration resistance of the construction and configuration of the overall protective clothing or protective ensemble, but especially of

seams, closures, and interfaces with other components such as gloves, boots, hoods, and respiratory protective equipment. It is intended that this test method be used to assess the liquid penetration resistance of protective clothing and protective ensembles as received from the manufacturer and worn in accordance with their instructions.

1.3 Resistance of materials used in protective clothing to permeation or penetration can be determined in accordance with Test Method F739 (or Test Method F1383 or F1407) and Test Method F903, respectively. Alternatively, resistance of materials used in protective clothing to penetration by synthetic blood or liquids containing virus can be determined in accordance with Test Methods F1670/F1670M and F1671/F1671M.

<sup>1</sup> This test method is under the jurisdiction of ASTM Committee F23 on Personal Protective Clothing and Equipment and is the direct responsibility of Subcommittee F23.30 on Chemicals.

Current edition approved Jan. 1, 2022. Published January 2022. Originally approved in 1991. Last previous edition approved in 2016 as F1359/F1359M – 16a. DOI: 10.1520/F1359\_F1359M-22.

1.4 The integrity of vapor protective ensembles is measured by its ability to maintain positive internal pressure with Test Method **F1052**.

1.5 The values in SI units or in other units shall be regarded separately as standard. The values stated in each system must be used independently of the other, without combining values in any way.

1.6 *This standard does not purport to address all of the safety concerns, if any, associated with its use. It is the responsibility of the user of this standard to establish appropriate safety, health, and environmental practices and determine the applicability of regulatory limitations prior to use.*

1.7 *This international standard was developed in accordance with internationally recognized principles on standardization established in the Decision on Principles for the Development of International Standards, Guides and Recommendations issued by the World Trade Organization Technical Barriers to Trade (TBT) Committee.*

## 2. Referenced Documents

2.1 *ASTM Standards:*<sup>2</sup>

**D1331** Test Methods for Surface and Interfacial Tension of Solutions of Paints, Solvents, Solutions of Surface-Active Agents, and Related Materials

**F739** Test Method for Permeation of Liquids and Gases Through Protective Clothing Materials Under Conditions of Continuous Contact

**F903** Test Method for Resistance of Materials Used in Protective Clothing to Penetration by Liquids

**F1052** Test Method for Pressure Testing Vapor Protective Suits

**F1383** Test Method for Permeation of Liquids and Gases Through Protective Clothing Materials Under Conditions of Intermittent Contact

**F1407** Test Method for Resistance of Chemical Protective Clothing Materials to Liquid Permeation—Permeation Cup Method

**F1670/F1670M** Test Method for Resistance of Materials Used in Protective Clothing to Penetration by Synthetic Blood

**F1671/F1671M** Test Method for Resistance of Materials Used in Protective Clothing to Penetration by Blood-Borne Pathogens Using Phi-X174 Bacteriophage Penetration as a Test System

2.2 *AATCC Standard:*<sup>3</sup>

**AATCC Test Method 135** Dimensional Changes in Automatic Home Laundering of Woven and Knitted Fabrics

## 3. Terminology

3.1 *Definitions:*

3.1.1 *liquid splash protective clothing, n*—protective clothing used to protect the wearer from liquid splashes and other forms of incidental liquid contact.

3.1.2 *liquid splash protective ensemble, n*—protective ensemble used to protect the wearer from liquid splashes and other forms of incidental liquid contact.

3.1.3 *penetration, n*—for chemical protective clothing, the movement of substances through voids in protective clothing materials or items on a nonmolecular level.

3.1.3.1 *Discussion*—Voids include gaps, pores, holes, and imperfections in closures, seams, interfaces, and protective clothing materials. Penetration does not require a change of state; solid chemicals move through voids in materials as solids, liquids as liquids, and gases as gases. Penetration is a distinctly different mechanism from permeation.

3.1.4 *permeation, n*—for chemical protective clothing, the movements of chemicals as molecules through protective clothing materials by the processes of (1) absorption of the chemical into the contact surface of the materials, (2) diffusion of the absorbed molecules throughout the material, and (3) desorption of the chemical from the opposite surface of the material.

3.1.4.1 *Discussion*—Permeation is a distinctly different mechanism from penetration.

3.1.5 *protective clothing, n*—an item of clothing that is specifically designed and constructed for the intended purpose of isolating all or part of the body from a potential hazard; or, isolating the external environment from contamination by the wearer of the clothing.

3.1.6 *protective ensemble, n*—the combination of protective clothing with respiratory protective equipment, hoods, helmets, gloves, boots, communication systems, cooling devices, and other accessories intended to protect the wearer from a potential hazard when worn together.

3.1.6.1 *Discussion*—For evaluating liquid penetration resistance, the protective ensemble includes only those clothing items or accessories that are necessary to provide resistance to liquid penetration.

## 4. Summary of Test Method

4.1 A properly fitting test specimen (protective clothing or protective ensemble) is placed on a standardized manikin that is already dressed in a specified liquid-absorptive garment covering portions of the manikin form that are of interest.

4.2 Water, treated to achieve a surface tension of  $0.032 \pm 0.002$  N/m [ $32 \pm 2$  dynes/cm], is sprayed at the test specimen from nozzles positioned in a specific configuration with respect to the specimen. The specimen is exposed to the liquid spray for a specified period in each of four specimen orientations.

4.2.1 In Procedure A, five nozzles are positioned in the same plane and directed towards the center of the manikin from specified locations above and to the sides of the manikin. The manikin is rotated  $45^\circ$  through each of four different orientations.

4.2.2 In Procedure B, three nozzles are positioned in a vertical line parallel to the vertical plane of the manikin and are

<sup>2</sup>For referenced ASTM standards, visit the ASTM website, [www.astm.org](http://www.astm.org), or contact ASTM Customer Service at [service@astm.org](mailto:service@astm.org). For *Annual Book of ASTM Standards* volume information, refer to the standard's Document Summary page on the ASTM website.

<sup>3</sup>Available from American Association of Textile Chemists and Colorists (AATCC), P.O. Box 12215, Research Triangle Park, NC 27709-2215, <http://www.aatcc.org>.

located and directed towards certain targets on the manikin. The manikin is rotated 90° through each of four different orientations.

4.3 Liquid penetration resistance is determined by the absence of observable wetting of the inner liquid-absorptive garment, or by the absence of observable liquid detected on the interior of the specimen, or both.

4.4 The test specimen is rated as passing if liquid does not penetrate and as failing if liquid does penetrate.

## 5. Significance and Use

5.1 This test method evaluates the ability of the construction and configuration of protective clothing or protective ensembles to resist liquid penetration. In most cases, the conditions used in this test method will not represent actual end-use conditions.

5.2 Two different spray configurations are used for exposing the protective clothing or protective ensemble on a manikin.

5.2.1 Procedure A involves five shower nozzles, with one nozzle directly above the clothed manikin and two nozzles each to upper and lower sides of the manikin that are all positioned in the same vertical plane. This spray configuration is intended to provide a full exposure of the entire protective clothing or protective ensemble system.

5.2.2 Procedure B involves three shower nozzles that are positioned at different heights on a vertical line that is parallel to the manikin with the locations and direction of each nozzle set with respect to targets on the manikin. This spray configuration is intended to provide a direct assessment of garment features such as the front closure.

5.3 The selected duration of the test is not intended to simulate user exposure to splashes of liquid substances but rather to provide sufficient time for enough liquid to penetrate to make visual detection easier. The default liquid exposure time for Procedure A is 20 min. The default liquid exposure time for Procedure B is 10 min.

5.3.1 It is permissible to specify shorter test durations. It is recommended that the duration of exposure be the same in each manikin orientation.

5.3.2 The choice of different test duration is partly based on the number of layers in the specimen being tested, some of which serve to absorb the surfactant-treated test liquid and result in attenuating the severity of the liquid challenge to the specimen.

5.4 A nontoxic, non-foaming surfactant is added to water for this test method to simulate liquids of lower surface tensions. Liquids of specific interest can be simulated by treating water to achieve an equivalent surface tension.

5.5 For protective clothing with water-repellent surfaces, the lower surface tension liquid will aid in the evaluation of the construction and configuration of the garment because it is less likely to be repelled and more likely to wet the protective clothing. This is especially useful for reusable garments whose water-repellent surface interferes with the evaluation of their construction and configuration when new, but is diminished after wearing and washing.

**TABLE 1 Manikin Dimensions**

Dimension	Measurement (mm) <sup>A</sup>
A – Height (from floor)	1828
B – Chest circumference	965
C – Shoulder circumference	1357
D – Waist circumference	800
E – Calf circumference	385
F – Shoulder pivot to floor	1420
G – Crotch height	865
H – Knee pivot to floor	480
I – Arm span	2194

<sup>A</sup>All dimensions  $\pm 12$  mm as shown in Fig. 1 corresponding to given letter; shoulder circumference (C) and pivot to floor height (F) determined at joint of manikin; arm span (I) determined with arms spread out horizontal at joint from sides of body.

5.6 Fluorescent or colored dyes are permitted to be added to the water to enhance detection of liquid penetration into the protective clothing or protective ensemble.

5.7 This test method can be used by both manufacturers and end users to assess liquid penetration resistance. Manufacturers can use this test method to evaluate quality of construction and effectiveness of clothing and ensemble configurations.

5.8 The clothing or ensemble is sized to fit the manikin. It is important that the clothing be selected to fit the manikin well since detection of liquid penetration requires as much contact as possible between the clothing or ensemble and the inner liquid-absorptive garment.

5.9 Results on a mismatched size of clothing or ensemble shall not be used to generalize about a particular construction or configuration. Manikin fit potentially affects liquid penetration resistance determinations.

5.10 There are no known restrictions to the types of protective clothing or protective ensembles that can be evaluated with this test method.

5.11 In some cases protective clothing or protective ensembles that show no liquid penetration during this test method will still fail to protect wearers against specific liquids due to the material degradation, penetration, or permeation or the effects associated with the vapors of liquid chemicals.

5.12 In some cases protective clothing or protective ensembles that show no liquid penetration during this test method will fail to protect wearers in specific circumstances as, for example, deluge or immersion.

## 6. Apparatus

6.1 *Human-Form Manikin*<sup>4</sup>—Use a human-form manikin for testing the protective clothing or protective ensemble. The preferred manikin is sized to meet the dimensions provided in Table 1 and as described in Fig. 1. This preferred manikin also has articulation at the shoulders, elbows, hips, and knees as shown in the example manikin presented in Fig. 2. Characteristics of the preferred manikin include a removable, non-rotating head, removable pliable hands, and removable feet

<sup>4</sup>The sole source of supply of the apparatus known to the committee at this time is Rubens Display World, 1482 E. Francis Street, Ontario, CA, 91761. If you are aware of alternative suppliers, please provide this information to ASTM International Headquarters. Your comments will receive careful consideration at a meeting of the responsible technical committee,<sup>1</sup> which you may attend.

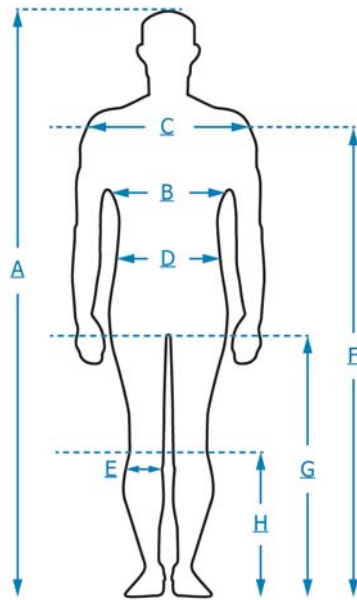

FIG. 1 Manikin Measurement Locations

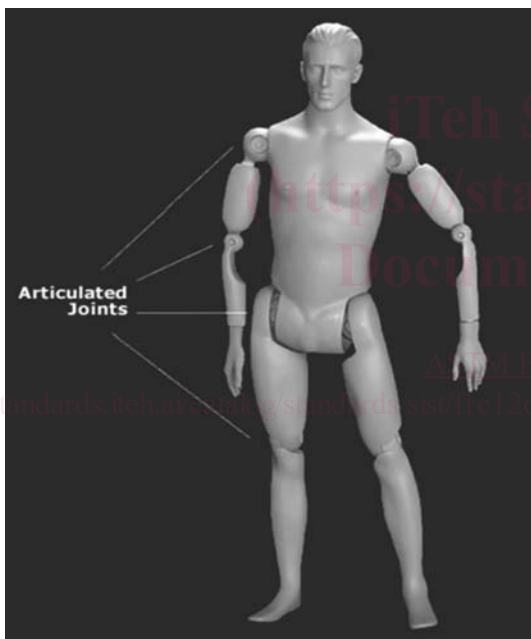

FIG. 2 Example of Articulated Manikin

torso-based inner garments that are constructed of medium gray, 270 to 550 g/m<sup>2</sup> [8 to 16 oz/yd<sup>2</sup>], 100 % cotton or cotton/polyester blend sweatshirt fleece fabric, which is finish free and that is easily watermarked. Orient the material so that the knit side is on the exterior while the fleece side is the interior surface. Launder the inner garment a minimum of ten times using AATCC Test Method 135, Machine Cycle 1, Wash Temperature V, and Drying Procedure Ai. Determine the suitability of the garment material by dispensing a 1 mL droplet of the surfactant-treated water specified in 9.1.1 on the fabric laying completely flat over a non-absorbent surface (such as a piece of wax paper) and measuring the largest diameter of the liquid mark. The fabric is suitable when the liquid mark has a diameter of at least 45 mm after 60 s following the application of the droplet on the fabric surface.

6.2.1 If multiple liquid-absorptive inner garments are used, avoid the use of tape or other non-absorbent materials for securing the individual garments onto the manikin in areas where liquid penetration is possible.

NOTE 1—The use of safety pins or double-sided tape underneath the liquid-absorptive inner garment is recommended for keeping the liquid-absorptive garments in place on the intended manikin body surface when the test garments are donned over the liquid-absorptive inner garments.

6.2.2 If testing a full ensemble, use a hood covering the appropriate areas of the head constructed of a fabric that shows the same liquid marking characteristics in 6.2 where a 1 mL droplet of surfactant-treated water prepared as described in 9.1.1 and dispensed on the fabric sample laying completely flat creates a liquid mark diameter that is greater than 45 mm after 60 s. If the ensemble hood interfaces with a respirator, use a hood that does not interfere with the placement of a facepiece.

6.2.3 If evaluating leakage into the gloves or glove to clothing interfaces, provide gloves constructed of a fabric that shows the same liquid marking characteristics in 6.2 where a 1 mL droplet of surfactant-treated water prepared as described

with a water-resistant coating that is shown to limit surfactant-treated liquid absorption in the manikin skin.

6.1.1 The use of an alternative manikin is permitted. If an alternative manikin is used, report the use of a different manikin in terms of manikin dimensions provided in Table 1.

6.1.2 Unless otherwise specified, the manikin is positioned so that the manikin body is in a full vertical orientation with the manikin head looking forward, manikin legs straight, and manikin arms pointing downward by the sides of the manikin torso.

6.2 *Liquid-Absorptive Inner Garment*—Use one or more inner garments to cover all areas of the manikin that are of interest as an aid to observe liquid penetration. Choose

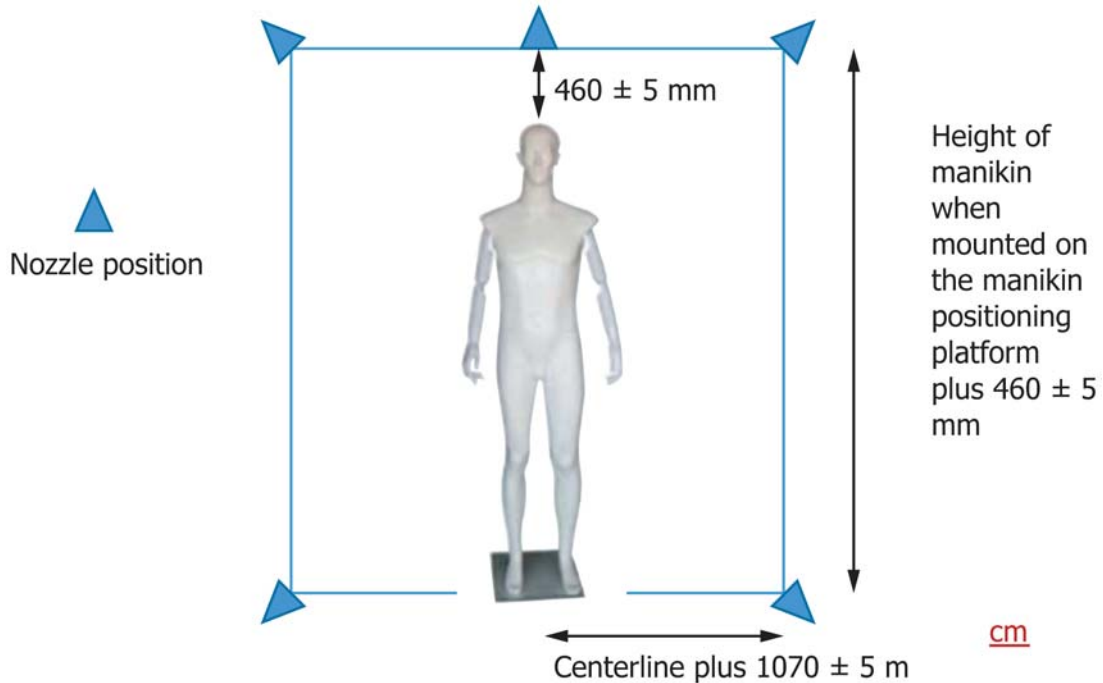

FIG. 3 Positions of Shower Nozzles with Respect to Manikin for Procedure A

in 9.1.1 and dispensed on the fabric sample laying completely flat creates a liquid mark diameter that is greater than 45 mm after 60 s.

6.2.4 If evaluating leakage into the footwear or footwear to clothing interfaces, provide socks constructed of a fabric that shows the same liquid marking characteristics in 6.2 where a 1 mL droplet of surfactant-treated water prepared as described in 9.1.1 and dispensed on the fabric sample laying completely flat creates a liquid mark diameter that is greater than 45 mm after 60 s.

6.3 *Standard Shower System (Procedure A)*—The standard shower system consists of five low-flow shower head nozzles and a pressurized liquid supply. The five nozzles are oriented with respect to the manikin as specified in Fig. 3. A laser pointing device shall be used for positioning each nozzle with respect to the manikin. The nozzles conform to the specifications given in Fig. 4.<sup>5</sup> The pressurized liquid is delivered at  $3.0 \pm 0.2$  L/min [ $48 \pm 3$  gal/h] through each nozzle and includes a means for monitoring the liquid flow through each nozzle during the test.

6.4 *Alternative Shower System (Procedure B)*—The alternative shower system consists of three low-flow shower head nozzles conforming to the specifications in Fig. 4,<sup>5</sup> and a pressurized liquid supply. The three nozzles are oriented with respect to the manikin as specified in Fig. 5 with detailed specifications provided in Annex A1 showing the specific

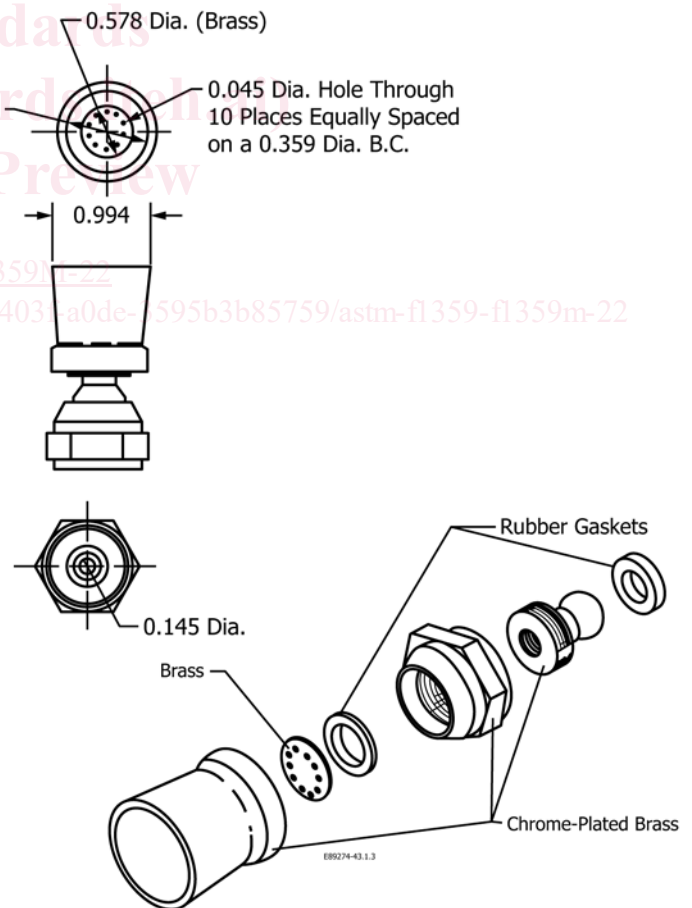

NOTE 1—All dimensions are in inches (1 in. = 25.4 mm). All dimensions are approximate to the nearest 0.01 in.

FIG. 4 Shower Nozzle Specifications

<sup>5</sup> Type #SS1B and SS1C nozzles meet this requirement. The sole source of supply of the nozzles known to the committee at this time is Whedon Products, Inc., 212 Andover Dr., West Hartford, CT 06107. If you are aware of alternative suppliers, please provide this information to ASTM International Headquarters. Your comments will receive careful consideration at a meeting of the responsible technical committee,<sup>1</sup> which you may attend.

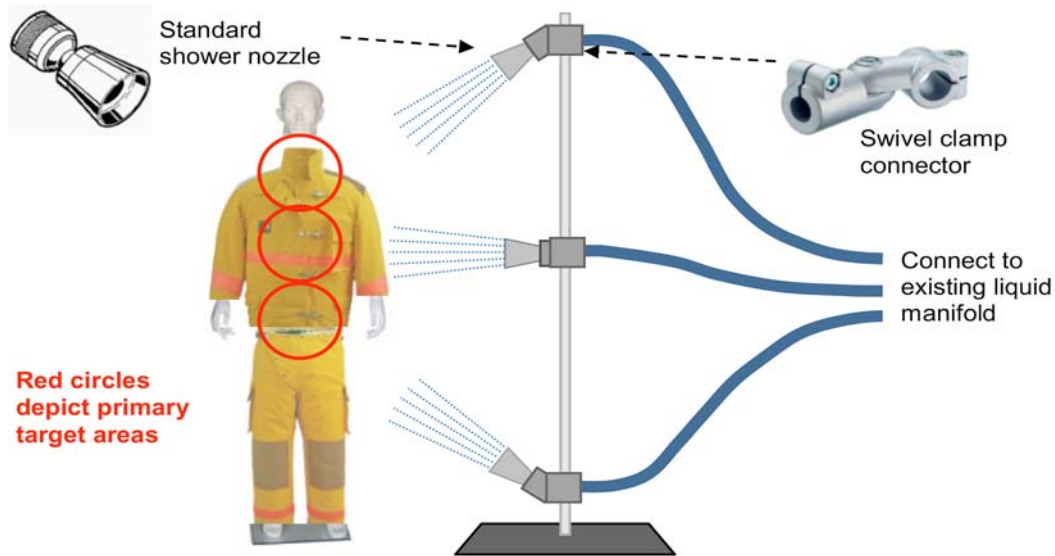

FIG. 5 Overview of Procedure B Shower System Configuration

targets on the manikin, distance from the nozzles, and method for properly aligning the manikin. Various means can be used for supporting the nozzles in a manner that ensures their positions are maintained over the duration of the testing. A laser pointing device shall be used for positioning the manikin. The pressurized liquid supply is delivered at  $3.0 \pm 0.2$  L/min [ $48 \pm 3$  gal/h] through each nozzle and includes a means for monitoring the liquid flow through each nozzle during the test.

**6.5 Manikin Positioning Platform**—A platform on which the feet of the manikin are secured to permit positioning of the manikin and nozzles with respect to the liquid spray. Choose a platform that has a means to allow its rotation to each of the required orientations while maintaining the manikin securely.

NOTE 2—Whether evaluated or not, use footwear on the manikin feet to allow the manikin to stand vertically. The use of snowboard footwear bindings or similar device is recommended for securing the manikin to the platform.

**6.6 Stopwatch**, or other appropriate timing device.

**6.7 Laser Pointing Device**, or similar device, to aid in positioning shower nozzles with respect to manikin.

## 7. Precautions

**7.1** Conduct the test method in an area designed to collect liquid runoff.

**7.2** Keep unprotected observers from being exposed to the test liquid.

**7.3** After testing, and before returning the specimen to service or storage if it is to be used, ensure the following:

**7.3.1** The specimen is dry, and

**7.3.2** The specimen has been cleaned to remove all surfactant residue, and is correctly assembled for reuse.

## 8. Specimen Preparation

**8.1** Protective clothing or protective ensemble components shall be tested as received unless otherwise specified. Select the size of the protective clothing or protective ensemble

components to be tested as correct for the size of the manikin for the dimensions provided in Table 1. If the manufacturer's instructions specify wearer weight as one of the parameters used in selecting the correct size of the garment, assume that the manikin has an equivalent human weight of 72.5 kg [160 lb]. These instructions shall account for putting the protective clothing or protective ensemble onto specified manikin. Duct tape and other nonuniform methods for closing or sealing interfaces shall not be used.

**8.2** Parts of the protective clothing or protective ensemble that are not to be tested shall be suitably blocked off with waterproof tape or other means to prevent liquid from penetrating those areas.

**8.2.1** For sealing the top of a non-hooded garment, place a suitably sized 1 mm or thicker plastic bag over the manikin head that extends over the top of the collar and seal with waterproof tape. Ensure that the tape is at least 25 mm above the portion of the collar for the protective clothing item that is being evaluated.

**8.2.2** For sealing off the sleeves of garments where no gloves are attached, a tapered open can or cylinder that fits inside the sleeve and is then taped to the sleeve is one means of isolating the sleeve end. An alternative means is to place a suitably sized 1 mm or thicker plastic bag over the sleeve end and seal with waterproof tape.

**8.2.3** For sealing off the face/respirator opening of a hooded garment, place a semi-rigid plastic cutout that is larger than the face opening when the garment is donned onto the manikin. Alternatively, block off the entire hood region in accordance with 8.2.1, ensuring that the sealed-off area is above the hood to garment seam and seal with waterproof tape.

## 9. Procedure

**9.1** Prior to each series of tests:

**9.1.1** Add a sufficient amount of a nontoxic, non-foaming surfactant to the water supply to achieve a surface tension of

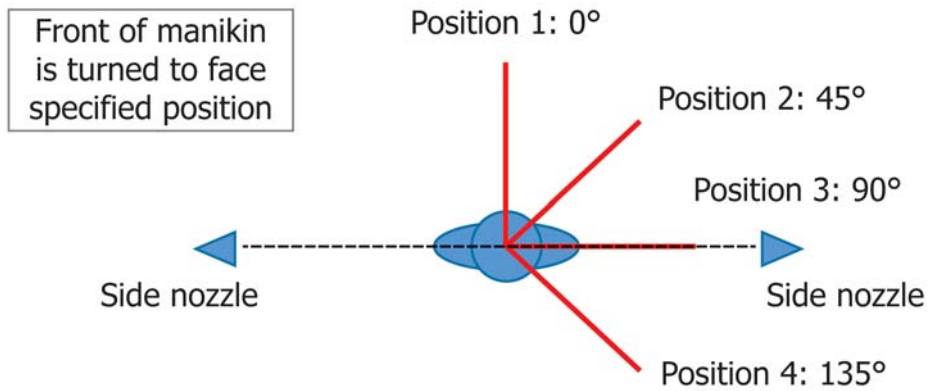

FIG. 6 Orientation of Suited Manikin Exposures for Procedure A

0.032 ± 0.002 N/m [32 ± 2 dynes/cm].<sup>6</sup> Periodically evaluate the surface tension of the challenge liquid using Test Method D1331. It is permissible to recirculate the liquid as long as the surface tension of the liquid is maintained over the test or series of testing being performed.

9.1.2 Check that the flow from each nozzle is uniform and the nozzle orifices are free from deposits or other effects that would affect the spray pattern; periodically clean the nozzles.

9.1.3 Calibrate the liquid flow rate through each nozzle at least 1 min following the initial of flow by collecting the total volume output through the respective nozzle over a 1 to 2 min period.

9.1.4 Inspect the liquid-absorptive inner garment and protective clothing or protective ensemble (and other ensemble components and equipment to be tested) for total dryness before using.

9.2 Put the liquid-absorptive inner garment(s) on the manikin. Use an inner garment or a combination of inner garments which cover all areas of the manikin that are of interest. Use inner liquid-absorptive hoods, gloves, and socks, as applicable.

9.3 Put the protective clothing or protective ensemble to be tested over the inner garment on the manikin in accordance with the manufacturer's instructions, accounting for any specialized instructions for placing the protective clothing or protective ensemble onto the manikin. Place and attach additional ensemble components and equipment, such as respirators, gloves, or footwear, on the manikin in accordance with the manufacturer's directions.

9.3.1 Unless otherwise specified, position the manikin with its head looking forward, arms pointing downward by the sides of the vertically oriented torso, and legs straight. Tighten the manikin joints to ensure that the manikin maintains this position during testing.

<sup>6</sup> A 0.1 weight % solution of Surfynol 104H with water gives a surface tension of approximately 33.8 dynes/cm. The sole source of supply of the apparatus known to the committee at this time is Air Products and Chemical, Inc., Performance Chemicals, Box 538, Allentown, PA 18105. If you are aware of alternative suppliers, please provide this information to ASTM International Headquarters. Your comments will receive careful consideration at a meeting of the responsible technical committee,<sup>1</sup> which you may attend.

9.4 Block off from exposure to the liquid spray any areas of the manikin or protective clothing or protective ensemble not being evaluated as specified in Section 8.

9.5 Spray liquid at the rate of 3.0 ± 0.2 L/min [48 ± 3 gal/h] through each nozzle simultaneously.

9.5.1 When using Procedure A, expose the suited manikin to the liquid spray for a period of 20 min, 5 min in each of four orientations shown in Fig. 6. Do not interrupt liquid spray when transitioning from one orientation to the next.

9.5.1.1 Alternatively, expose the suited manikin for a different period of time divided into four equal periods for exposing the manikin in each of the four orientations.

9.5.2 When using Procedure B, expose the suited manikin for a total of 10 min with the suited manikin exposed to the liquid spray for 2.5 min, +5 s, -0 s, in the following sequence: 0°, 90°, 180°, and 270°, in accordance with the orientations shown in Fig. 7. Do not interrupt the liquid spray in transitioning from one orientation to another.

9.6 At the end of the liquid spray period following either Procedure A or Procedure B, remove excess liquid from the surface of the test garment. Absorbent toweling is one method that works well. Do not apply excessive pressure in wiping off the test garment exterior.

NOTE 3—The purpose of exterior drying is to prevent the transfer of exterior liquid to the interior of the test ensemble or garment, or to the inner liquid-absorbent garments. Since the characteristics of exterior materials will have different propensities for absorbing challenge liquid, drying procedures can be adapted depending on the amount of residual liquid on the specimen exterior, if liquid has pooled in any one area, and the type of garment being evaluated.

9.7 Remove the test protective clothing or protective ensemble in a dry area and any other ensemble components or equipment from the manikin. Complete both the drying of the test garment or ensemble and their removal from the manikin within 10 min following the conclusion of the liquid spray period.

9.8 Inspect the protective clothing or protective ensemble following the liquid spray period for evidence of liquid penetration. Determine liquid penetration by one of the following procedures: