



Designation: C736 – 12 (Reapproved 2022)

Standard Test Method for Extension-Recovery and Adhesion of Latex Sealants¹

This standard is issued under the fixed designation C736; the number immediately following the designation indicates the year of original adoption or, in the case of revision, the year of last revision. A number in parentheses indicates the year of last reapproval. A superscript epsilon (ϵ) indicates an editorial change since the last revision or reapproval.

1. Scope

1.1 This test method covers a laboratory procedure for the determination of the extension-recovery and adhesion of latex sealants.

1.2 The values stated in SI units are to be regarded as standard. The values given in parentheses after SI units are provided for information only and are not considered standard.

1.3 *This standard does not purport to address all of the safety concerns, if any, associated with its use. It is the responsibility of the user of this standard to establish appropriate safety, health, and environmental practices and determine the applicability of regulatory limitations prior to use.*

NOTE 1—A related ISO standard is ISO 7389. Users should compare to determine how the ISO standard differs from this test method.

1.4 *This international standard was developed in accordance with internationally recognized principles on standardization established in the Decision on Principles for the Development of International Standards, Guides and Recommendations issued by the World Trade Organization Technical Barriers to Trade (TBT) Committee.*

2. Referenced Documents

2.1 *ASTM Standards:*²

C717 Terminology of Building Seals and Sealants

C1375 Guide for Substrates Used in Testing Building Seals and Sealants

2.2 *ISO Standard:*³

ISO 7389 Building Construction—Sealants—Determination of Elastic Recovery

¹ This test method is under the jurisdiction of ASTM Committee C24 on Building Seals and Sealants and is the direct responsibility of Subcommittee C24.30 on Adhesion.

Current edition approved Jan. 1, 2022. Published January 2022. Originally approved in 1972. Last previous edition approved in 2017 as C736 – 12 (2017). DOI: 10.1520/C0736-12R22.

² For referenced ASTM standards, visit the ASTM website, www.astm.org, or contact ASTM Customer Service at service@astm.org. For *Annual Book of ASTM Standards* volume information, refer to the standard's Document Summary page on the ASTM website.

³ Available from the American National Standards Institute, 11 W. 42nd St., 13th Floor, New York, NY 10036.

3. Terminology

3.1 *Definitions*—Refer to Terminology C717 for definitions of the terms used in this test method.

4. Summary of Test Method

4.1 A joint of prescribed dimensions, between glass and aluminum plates is filled with the sealant. After an aging period, the joint width is increased 25 %, the force is removed, and the specimen is permitted to recover. The amount of recovery and the percent of adhesion loss are measured.

5. Significance and Use

5.1 This test method evaluates the performance of a latex sealant in joints subjected to a limited amount of extension.

6. Apparatus

6.1 *Extension Machine* that can be operated at a steady rate of 12.7 mm/min (0.5 in./min) and held at constant extension for 5 min.

6.2 *Aluminum Alloy Plates*, six, anodized, 6.4 mm by 25.4 mm by 76.2 mm (¼ in. by 1 in. by 3 in.). Plates shall conform to Guide C1375.

6.3 *Glass Plates*, six, 6.4 mm by 25.4 mm by 76.2 mm (¼ in. by 1 in. by 3 in.). Plates shall conform to Guide C1375.

6.4 *U Shaped Spacers*, six, as shown in Fig. 1(a) made of a rigid, nonadhering material such as polyethylene, TFE-fluorocarbon, or release-covered metal.

6.5 *Metal C Clamps*, twelve.

6.6 *Circulating Air Oven*, capable of maintaining 50 °C ± 1 °C (122 °F ± 2 °F).

7. Sampling

7.1 Take the sealant to be tested directly from the container as commercially supplied by the manufacturer.

8. Test Specimens

8.1 Prepare a test specimen as follows: Apply a bead of sealant, 12.7 mm by 12.7 mm by 50.8 mm (½ in. by ½ in. by 2 in.) between parallel glass and anodized aluminum plates as shown in Fig. 1(b), using rigid, nonadhering spacer bars. Use the C-clamps to hold the test assembly during the filling and subsequent curing and handling of the specimens.

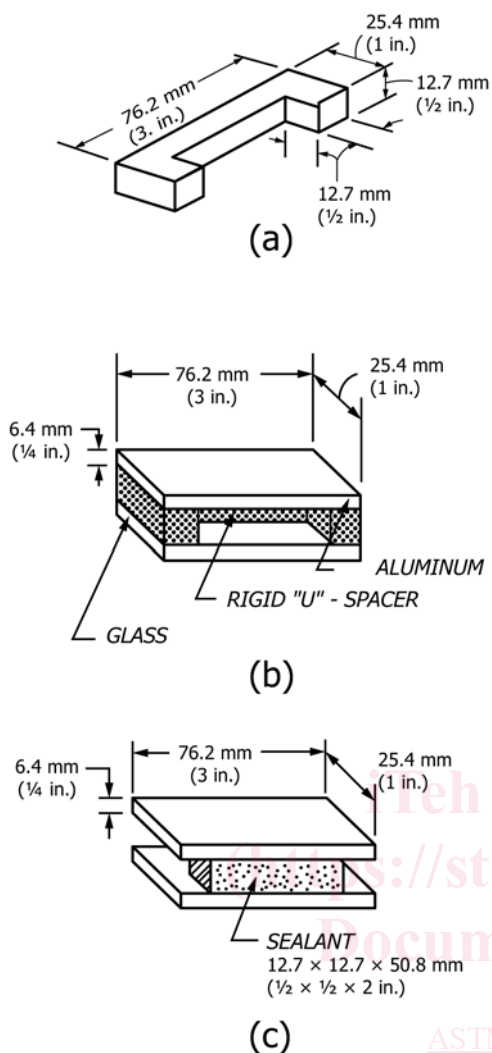

FIG. 1 Preparation of Test Specimen

TABLE 1 Precision and Bias Data—Percent Recovery

| Material | Average Recovery, % | Estimated Standard Deviation (Within Laboratory) | Estimated Standard Deviation (Between Laboratory) | Repeatability (Internal) | Reproducibility |
|----------|---------------------|--|---|--------------------------|-----------------|
| G1 | 100.00 | 0.00 | 0.00 | 0.00 | 0.00 |
| G2 | 91.67 | 14.43 | 20.41 | 40.85 | 57.77 |
| G3 | 100.00 | 0.00 | 0.00 | 0.00 | 0.00 |

TABLE 2 Precision and Bias Data—Percent Adhesion Loss

| Material | Average Adhesion Loss, % | Estimated Standard Deviation (Within Laboratory) | Estimated Standard Deviation (Between Laboratory) | Repeatability (Internal) | Reproducibility |
|----------|--------------------------|--|---|--------------------------|-----------------|
| G1 | 8.084 | 20.29 | 20.29 | 57.41 | 57.41 |
| G2 | 0.001 | 0.00 | 0.00 | 0.00 | 0.00 |
| G3 | 0.001 | 0.00 | 0.00 | 0.00 | 0.00 |

8.2 Prepare five additional specimens as described in 8.1.

NOTE 2—The glass and aluminum plates shall be cleaned with methyl ethyl ketone or similar solvent followed by a thorough cleaning with a

detergent solution and a final rinse with distilled or deionized water and then air dried prior to assembly of specimens.

9. Conditioning

9.1 Cure the six test specimens for 7 days at standard conditions, then for 7 days at 50 °C ± 1 °C (122 °F ± 2 °F). After the 14-day cure period, condition the specimens for 2 h at standard conditions.

10. Procedure

10.1 Remove the spacers (Fig. 1(c)) and insert each specimen in turn in the extension machine. At the rate of 12.7 mm/min (0.5 in./min), extend the joint width 25 % to 15.9 mm (0.625 in.) and hold at this width for 5 min, meanwhile inspecting the sealant for cohesive or adhesive failure, or both.

10.2 Release the force and allow the specimen to recover. If the specimen must be removed from the machine to recover, insert a 15.9-mm (0.625-in.) spacer bar during the transfer and then immediately remove for recovery.

10.3 Allow the specimen to stand with the sealant surface uppermost undisturbed for a period of 2 h. Measure the joint width at the end of this period and determine the percent of adhesive failure to both glass and aluminum.

11. Calculation and Interpretation of Results

11.1 Percent Recovery—Determine the percent recovery, *D*, as follows:

$$D = [(A - B)/(A - C)] \times 100 \quad (1)$$

where:

- A* = extended joint width = 15.9 mm (0.625 in.) (by definition of procedure),
- B* = joint width after recovery (as measured), and
- C* = original joint width = 12.7 mm (0.5 in.).

11.2 Percent Adhesive Failure—Determine the percent adhesive failure to both glass and aluminum by measurement.

12. Report

12.1 Report for each of the six specimens, the percent recovery, percent adhesive failure to both glass and aluminum on all six specimens, and the total area of adhesive failure in square centimetres (square inches) among the six specimens.

13. Precision and Bias⁴

13.1 Precision—The precision calculations for this test method are based on the results of four laboratories testing three materials, each in triplicate. The results are given in Tables 1 and 2.

13.1.1 Percent Recovery—At 95 % confidence a variation of as much as 40.85 % can be expected within a laboratory and 57.77 % between laboratories (see Table 1).

13.1.2 Percent Adhesive Failure—At 95 % confidence a variation of as much as 57.41 % can be expected both within a laboratory and between laboratories (see Table 2).

⁴ Supporting data is available from ASTM Headquarters. Request RR:C24-1025.